

Grant Vortex

Outdoor Combi Condensing Oil Boiler Range

Installation and Servicing Instructions

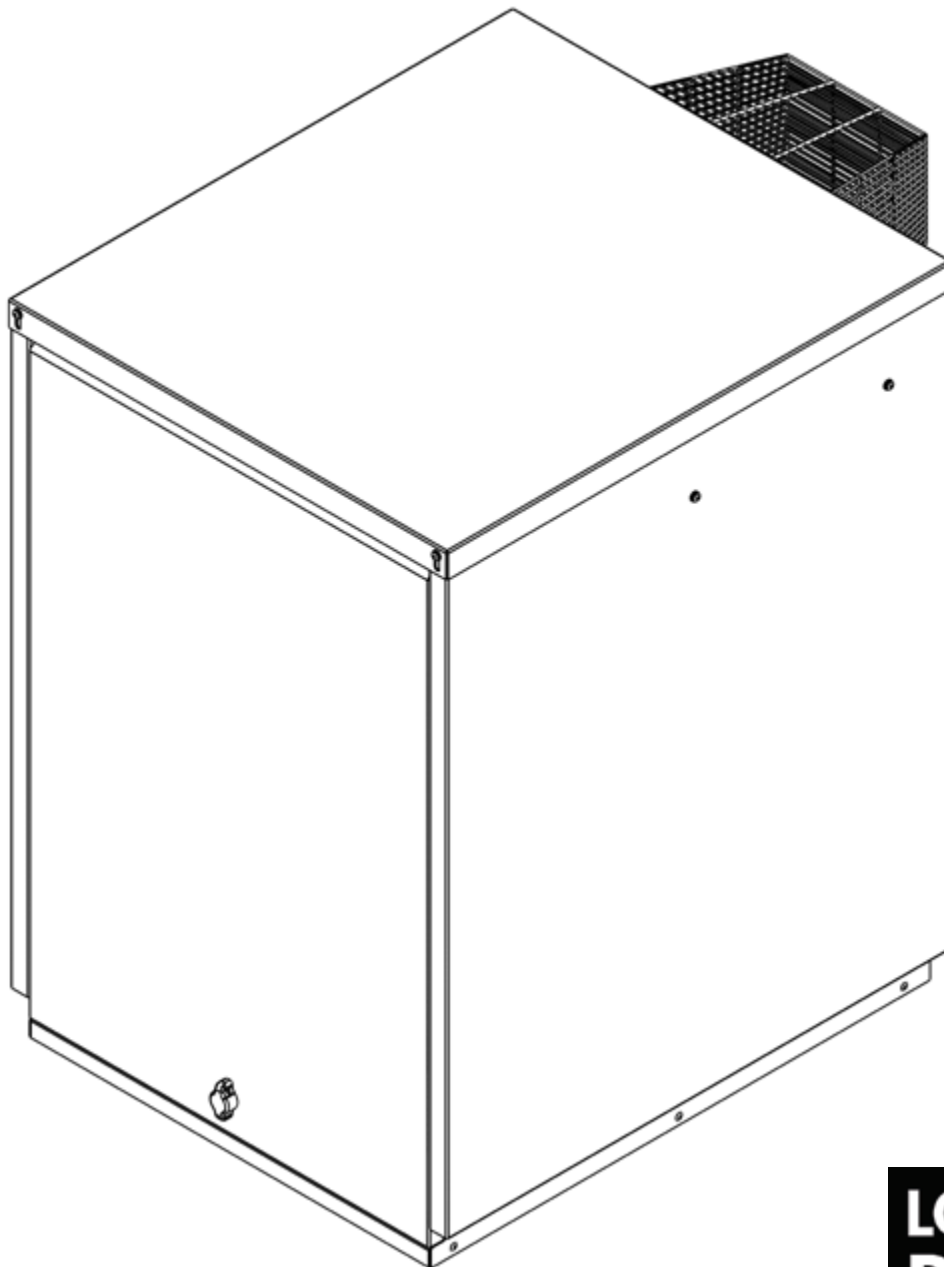

**LOW NO_x
READY**



5 056003 734836 >



IMPORTANT NOTE FOR INSTALLERS

These instructions are intended to guide installers on the installation, commissioning and servicing of the Grant Vortex oil boiler. After installing the boiler, leave these instructions with the user.

A user handbook is available to guide users in the operation of the oil boiler.

SPECIAL TEXT FORMATS

The following special text formats are used in these instructions for the purposes listed below:

! WARNING !

Warning of possible human injury as a consequence of not following the instructions in the warning.

! CAUTION !

Caution concerning likely damage to equipment or tools as a consequence of not following the instructions in the caution.

! NOTE !

Used for emphasis or information not directly concerned with the surrounding text but of importance to the reader.

PRODUCT CODES AND SERIAL NUMBERS COVERED

The serial numbers used on Grant oil boilers consist of a fifteen digit numerical code with the final three digits being the product identifier.

For example:

100000200218743

These instructions cover the following product codes and serial numbers:

Product code	Serial number identifier
VTXOMCOMBI21	743
VTXOMCOMBI26	744
VTXOMCOMBI36	745

SERVICING

The boiler should be serviced at least every twelve months and the details entered in the Service Log in the user handbook.

FUEL TYPE

All Grant Vortex boilers are suitable for use with Class C2 Kerosene. To use Bio-Kerosene (B30K), refer to the information below:

OPERATION ON BIO-FUEL

All Grant Vortex condensing boilers manufactured since May 2011 are suitable for operation on both standard Kerosene (Class C2 to BS 2869) and also bio-kerosene - up to a 30% blend (B30K).

All burner settings and nozzle sizes (as detailed in Section 2.2 of these instructions) are correct for both standard kerosene and bio-kerosene (B30K).

In order to operate this boiler on bio-kerosene, it will be necessary to take the following actions:

- Use a bio-kerosene (B30K) compatible flexible oil line in place of the oil line supplied with the boiler.
- Have the oil storage tank and oil supply line (including all pipework, sight gauges, filters, isolating valves, fire valves, de-aeration devices, etc.) checked for their compatibility with bio-kerosene (B30K).

Where necessary, some or all of these items may have to be replaced with a bio-kerosene compatible alternative.

- Check the suitability of the flue system with Grant UK.
- Use only bio-kerosene (B30K) that conforms to OPS24.

IMPORTANT:

Under no circumstances, should the boiler be used with bio-kerosene without the above actions being taken first.

! NOTE !

This appliance can be used by children aged from 8 years and above and persons with reduced physical, sensory or mental capabilities or lack of experience and knowledge if they have been given supervision or instruction concerning use of the appliance in a safe way and understand the hazards involved.

Children shall not play with the appliance. Cleaning and user maintenance shall not be made by children without supervision.



GRANT ENGINEERING (UK) LIMITED

Hopton House, Hopton Industrial Estate, Devizes, Wiltshire, SN10 2EU

Tel: +44 (0)1380 736920 Fax: +44 (0)1380 736991

Email: info@grantuk.com www.grantuk.com

This manual is accurate at the date of printing but will be superseded and should be disregarded if specifications and/or appearances are changed in the interests of continued product improvement. However, no responsibility of any kind for any injury, death, loss, damage or delay however caused resulting from the use of this manual can be accepted by Grant Engineering (UK) Limited, the author or others involved in its publication.

All goods sold are subject to our official Conditions of Sale, a copy of which may be obtained on application.

© Grant Engineering (UK) Limited. No part of this manual may be reproduced by any means without prior written consent.

CONTENTS

1	INTRODUCTION	4			
1.1	How a condensing boiler operates	4		9.3	Conventional flue systems
1.2	Boiler description	4		9.4	External vertical conventional flue (Green System)
1.3	Flue options	4		9.5	External horizontal conventional flue (Green System)
1.4	Boiler components	5		9.6	Flue clearances
2	TECHNICAL DATA	6			
2.1	Boiler technical data	6	10	COMMISSIONING	33
2.2	Burner settings	7		10.1	Before switching on
2.3	Flue gas analysis	7		10.2	Burner settings: RDB 2.2 BX burners
2.4	Boiler dimensions	7		10.3	Air adjuster disc: Combi 21 only
3	OIL STORAGE AND SUPPLY SYSTEM	8		10.4	Switching on
3.1	Fuel supply	8		10.5	Running the boiler
3.2	Burner oil connection	10		10.6	Balancing the system
4	INSTALLATION	12		10.7	Completion
4.1	Introduction	12		10.8	Information for the user
4.2	Boiler location	12			
4.3	Regulations compliance	12	11	SERVICING	38
4.4	Heating system design considerations	12		11.1	Checks before servicing
4.5	Pipework materials	13		11.2	Dismantling prior to servicing
4.6	Connections	13		11.3	Cleaning the boiler
4.7	Preparation for installation	13		11.4	Cleaning the burner: RDB 2.2 BX burners
4.8	Installing the boiler	14		11.5	Adjusting the diffuser
4.9	Expansion vessel	14		11.6	Air adjuster disc: Combi 21 only
4.10	Filling the heating system	14		11.7	Recommissioning
4.11	Before you commission	14		11.8	Burner components
4.12	Completion	14			
5	PIPE CONNECTIONS	15	12	FAULT FINDING	43
5.1	Water connections	15		12.1	Initial checklist- For installers or service engineers
5.2	Making the water connections	16		12.2	Main fault finding procedures
5.3	Domestic hot water system	16		12.3	Poor hot water checklist
5.4	To use the water hardness kit	16		12.4	Burner fault finding - Riello RDB burners
6	CONDENSATE DISPOSAL	17	13	SPARE PARTS	48
6.1	General requirements	17		13.1	Boiler parts list
6.2	Connections	17		13.2	Sealed system parts list
6.3	Pipework	17		13.3	Riello RDB 2.2 BX burners
6.4	External pipework	17			
6.5	Condensate soakaway	18	14	DECLARATION OF CONFORMITY	52
6.6	Condensate trap	18			
6.7	Condensate disposal pipework	19	15	HEALTH AND SAFETY INFORMATION	53
6.8	Inspection and cleaning of trap	19		15.1	Insulation materials
7	SEALED SYSTEMS	20		15.2	Sealant and adhesive
7.1	Sealed system requirements	20		15.3	Kerosene and Gas Oil fuels
7.2	Filling the sealed system	21			
7.3	Venting the pump	21	16	END OF LIFE INFORMATION	54
7.3	Pressure relief (safety) valve operation	21			
8	ELECTRICAL	22	17	PRODUCT FICHE	55
8.1	General	22			
8.2	Connecting the power supply	22	18	GUARANTEE	56
8.3	Connecting the controls - Heating only	24			
8.4	Connecting the controls - Heating and Hot Water	25	A1	WILO YONOS PARA RS RKC CIRCULATING PUMP	58
8.5	Connecting a remote frost thermostat	26			
9	FLUE SYSTEM AND AIR SUPPLY	27	A2	WILO-PARA 25-130/7-50/SC-6#GRA CIRCULATING PUMP	60
9.1	Air supply	27			
9.2	Plume diverter kit	27			

1 INTRODUCTION

1.1 HOW A CONDENSING BOILER OPERATES

During the combustion process, hydrogen and oxygen combine to produce heat and water vapour. The water vapour produced is in the form of superheated steam in the heat exchanger. This superheated steam contains sensible heat (available heat) and latent heat (heat locked up in the flue gas). A conventional boiler cannot recover any of the latent heat and this energy is lost to the atmosphere through the flue.

The Grant Vortex condensing boiler contains an extra heat exchanger which is designed to recover the latent heat normally lost by a conventional boiler. It does this by cooling the flue gases to below 90°C, thus extracting more sensible heat and some of the latent heat. This is achieved by cooling the flue gases to their dew point (approximately 55°C).

To ensure maximum efficiency, the boiler return temperature should be 55°C or less, this will enable the latent heat to be condensed out of the flue gases.

- The boiler will achieve net thermal efficiencies of 100%.

To achieve maximum performance from the Grant Vortex boiler, it is recommended that the heating system is designed so that a temperature differential of 20°C between the flow and return is maintained.

The Grant Vortex boiler will however still operate at extremely high efficiencies even when it is not in condensing mode and therefore is suitable for fitting to an existing heating system without alteration to the radiator sizes. The boiler is capable of a maximum flow temperature of 75°C.

1.2 BOILER DESCRIPTION

Grant Vortex Pro External Combi modules have an insulated weatherproof enclosure made of galvanised steel with a powder coated finish, and are designed for external installation, either against a wall or free standing some distance away from the property, as required.

The Grant Vortex Pro Combi range of automatic pressure jet oil boilers have been designed for use with a sealed central heating system and will supply domestic hot water at mains pressure.

The boilers are suitable for use on sealed central heating systems only. All combi models are supplied with the necessary components factory fitted. Refer to Section 7.

All boilers are supplied with the control panel and burner factory fitted.

All the models in the current Grant Vortex Pro Combi range of boilers are designed to comply with the maximum NOx emissions under the Energy-related Products Directive (ErP).

* From the 26th September 2018, the maximum NOx emissions for all new oil fired boilers (up to and including 400kW for both new build and replacement boiler installations) is 120mg/kWh.

1.3 FLUE OPTIONS

Grant Vortex Pro External Combis are supplied with a low level discharge flue system, which can either be fitted to the rear, left hand or right hand flue outlet position, as required.

It is possible to discharge the products of combustion at a higher level by using the following components from the Grant 'Green' flue system:

- External module starter (available as a straight section or with a 90° elbow, enabling the installer to use any flue outlet from the boiler casing)
- Fixed extensions 150mm, 250mm, 450mm and 950mm
- Adjustable extension 195 to 270mm
- 45° elbow
- High level 90° or vertical terminal

It is possible to extend the flue system by 19m vertically (from the boiler outlet) using this system.

Should the flue system need to navigate around objects, the green system can be used to horizontally extend the flue system by up to 3m from the centre of the boiler outlet.

Please note, the flue may either be brought up vertically from the boiler, or horizontally. Not a combination of the two.

Alternatively, the plume diverter kit, available from Grant UK, can be used to vertically extend the flue system.

Please see Sections 4.7 and 9 for more detailed instructions on how to install the flue system.

Conventional flues only may be fitted to Grant Vortex Pro External Combi boilers.

! NOTE !

The flue system materials and construction MUST be suitable for use with oil-fired condensing boilers. Failure to fit a suitable conventional flue may invalidate the guarantee on the boiler.

1.4 BOILER COMPONENTS

All burners are pre-set for use with kerosene and are supplied ready to connect to a single pipe fuel supply system with a loose flexible fuel line and 3/8" to 1/4" BSP male adaptor supplied with the boiler.

If required, an additional flexible fuel line (900 mm in length, product code: RBS36 or 600mm in length, product code: RBS36XS) and 3/8" to 1/4" BSP male adaptor (product code: Z3003602) are available to purchase from Grant UK, for two-pipe oil supply systems.

The temperature of the water leaving the boiler to heat the radiators is user adjustable.

The setting of the boiler thermostat on the Vortex Pro Combi boilers has no affect on the hot water performance.

The boiler is fitted with an overheat thermostat (which allows it to be used on a sealed central heating system) which will automatically switch off the boiler if the heat exchanger exceeds a pre-set temperature of 110°C ± 3°C.

The control panel is fitted with an ON/OFF switch, service switch, indicator lights, boiler thermostat, pressure gauge and manual reset for the overheat thermostat.

Figure 1-1 shows the details of the control panel for the Vortex Pro External Combi.

Please refer to Figure 10-2 for a visual representation of the boiler components.

1.4.1 BOILER CONTROLS

To access the control panel, remove the front door panel from the boiler. The controls on the panel are as follows:

Boiler On/Off switch

This switches the boiler on and off. The boiler ON/OFF switch incorporates a 'mains on' neon which lights when the boiler is switched on. Please note that the 'mains on' neon does not necessarily indicate that the burner is firing. See Boiler Indicator Lights information in the next column.

When the ON/OFF switch is set to on, the POWER indicator LED on the control panel will also light. This also does not necessarily indicate that the boiler is firing.

! NOTE !

If the ON/OFF switch is set to off the boiler will NOT supply central heating or domestic hot water. The built-in frost thermostat will also not operate.

Service/Test Switch (External Modules only)

A Service switch is fitted to the control panel to allow the Service Engineer to test-fire the boiler.

Heating Thermostat

This control allows the temperature of the water leaving the boiler to heat the radiators to be adjusted. This will be set by the installer to the optimum temperature for efficient operation of the boiler. It should be left set in this position.

Boiler Indicator Lights

These red LEDs, located on the boiler control panel, indicate the operating situation of the boiler as below:

PUMP	Power to the relevant circulating pump.
POWER	Mains power to the boiler is switched on.
FLOW	DHW flow switch has been triggered.
DEMAND	Demand for heating (and/or hot water) from the heating system controls.
OVERHEAT	Boiler overheat thermostat has operated and switched the boiler off.
BURNER	Power to the burner for it to operate.

Overheat Thermostat (Overheat Reset)

The boiler is fitted with a safety overheat thermostat which will automatically switch off the boiler in the case of a control malfunction causing overheating.

System Pressure Gauge

This is to indicate the water pressure in the sealed heating system.

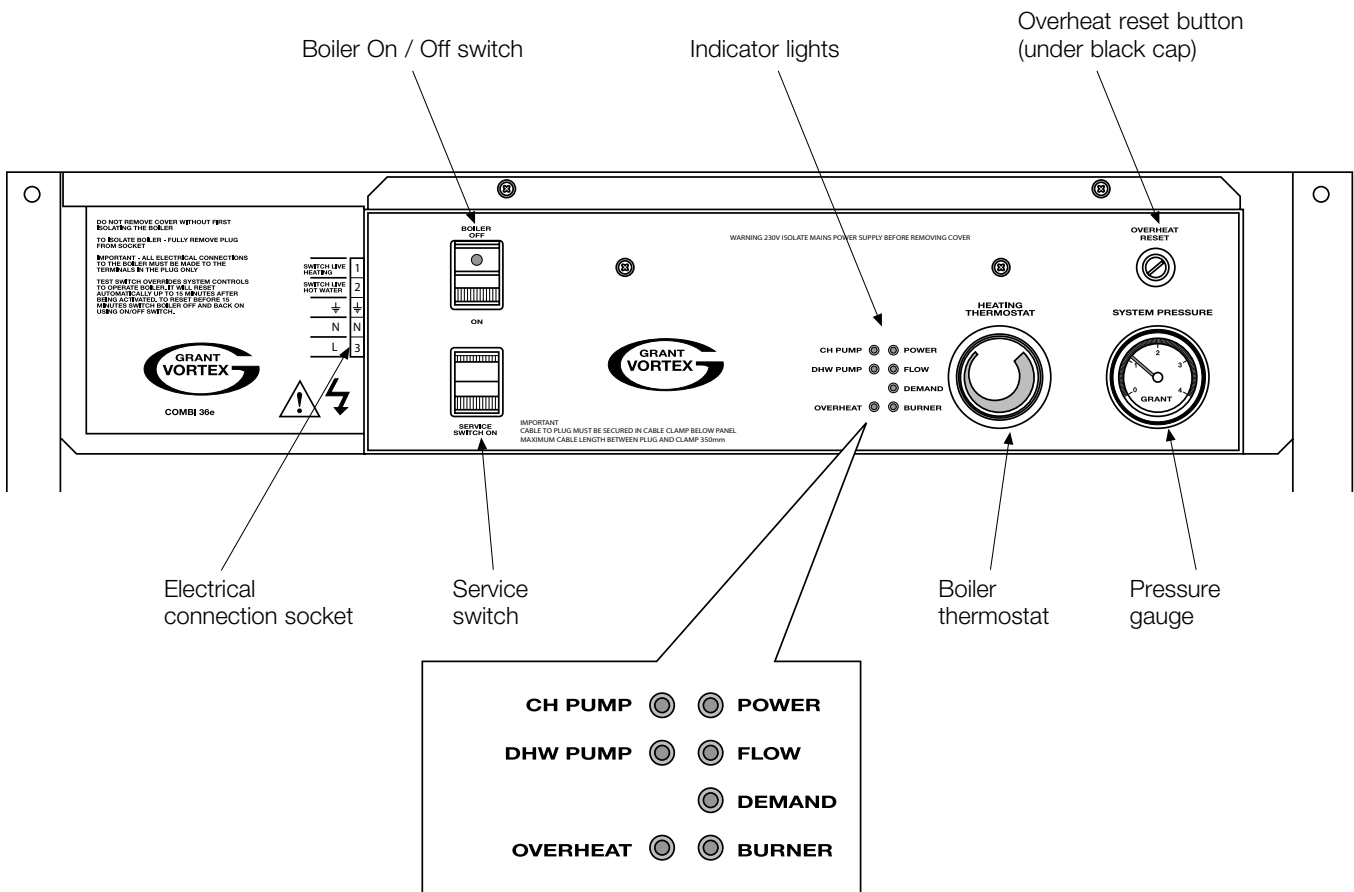

Figure 1-1: Vortex Pro External Combi control panel

2 TECHNICAL DATA

2.1 BOILER TECHNICAL DATA

Table 2-1: Boiler technical data

	Units	Outdoor		
		Combi 21	Combi 26	Combi 36
Water content (including 32 litre primary store)	litre	48.0	48.5	53.5
	gal	10.6	10.7	11.8
Weight (dry) *	kg	147	188	218
	lb	325	415	481
Maximum heat output (Kerosene)	kW	21	26	36
	Btu/h	71,600	88,700	122,800
Heating system flow and return connections	mm	22	22	28
Cold water mains inlet	mm	15	15	22
Domestic hot water outlet	mm	15	15	22
Minimum flow rate ($\Delta T=10^{\circ}\text{C}$)	l/h	1,800	2,200	3,000
Minimum flow rate ($\Delta T=20^{\circ}\text{C}$)	l/h	900	1,100	1,500
Pressure relief valve discharge	mm	15		
Maximum heating system pressure (cold)	bar	1.0		
Minimum heating system pressure (cold)	bar	0.5		
Expansion vessel volume (pre-charged at 1 bar)	litres	24		
Maximum heating system volume **	litres	255		
Minimum domestic hot water flow rate		3.0 litres/min (0.66 gal/min)		
Maximum domestic hot water temperature	$^{\circ}\text{C}$	65 (factory set)		
Maximum mains water inlet pressure	bar	8.0		
Minimum recommended mains water inlet pressure	bar	2.5		
Condensate connection		22 mm (only connect plastic pipe)		
Flue diameter (conventional)	mm	100		
Waterside resistance $\Delta T=10^{\circ}\text{C}$	mbar	28.5		26.0
Waterside resistance $\Delta T=20^{\circ}\text{C}$	mbar	10.0		9.5
Maximum static head	m	28		
Minimum circulating head	m	1		
Boiler thermostat range	$^{\circ}\text{C}$	65 to 75		
Limit (safety) thermostat shut off temperature	$^{\circ}\text{C}$	110 \pm 3		
Maximum hearth temperature	$^{\circ}\text{C}$	Less than 50		
Electricity supply		~230 1ph 50Hz 5A fused		
Burner motor power	Watts	90		
Absorbed motor power	kW	0.15		
Starting current	Amps	4.2	2.6	2.6
Running current	Amps	0.85		
Oil connection		1/4" BSP male (on end of flexible fuel hose)		
Conventional flue draught	mbar	Minimum: 0.087 - Maximum: 0.37		
	in wg	Minimum: 0.035 - Maximum: 0.15		
Maximum operating pressure	bar	2.0		
Maximum operating pressure - pressure relief valve	bar	2.5		
Boiler type		ON/OFF		

* Weight includes burner (and expansion vessel) but excludes flue

** Based on expansion vessel charge and initial cold system pressure of 0.5 bar

2.2 BURNER SETTINGS

Table 2-2: Burner settings

Boiler models (burner type)	Heat output		Nozzle	Oil pressure (bar)	Smoke No.	Burner head type	Burner head/ air disc setting	Distance D ^s (mm)	Fuel flow rate (kg/h)	Flue gas temp. (°C)	CO ₂ (%)	Flue gas VFR ‡ (m ³ /hr)
	(kW)	(Btu/h)										
Outdoor Combi 21 (Riello RDB2.2 BX E15/21)	21.0	71,600	0.60/60°ES	8.0	0 - 1	BX 500	Disc: C	13	1.84	75 - 80	12.5	23.0
Outdoor Combi 26 (Riello RDB2.2 BX VC26)	26.0	88,700	0.75/60°ES	8.5	0 - 1	BX 500	N/A	15	2.16	75 - 80	12.5	28.5
Outdoor Combi 36 (Riello RDB2.2 BX VC36)	36.0	122,800	1.00/60°ES	9.0	0 - 1	BX 700	N/A	17.5	2.99	75 - 80	12.5	39.5

Notes:

‡ Flue gas VFR: Flue gas volumetric flow rate

1. The data given above is approximate only and is based on the boiler being used with a low level balanced flue.

2. The above settings may have to be adjusted on site for the correct operation of the burner.

3. Gas Oil is NOT suitable for use with Grant Vortex boiler range

4. The flue gas temperatures given above are ± 10%.

5. When commissioning, the air damper **must be** adjusted to obtain the correct CO₂ level.

6. The combustion door test point may be used for CO₂ and smoke readings only. Do not use this test point for temperature or efficiency readings.

7. When commissioning the Combi 21, the position of the air adjuster disc should be checked. Refer to Section 10.3 (Air Adjuster Disc).

8. Refer to Section 10.2 for information on how to set Distance D (Figure 10-5).

2.3 FLUE GAS ANALYSIS

To allow the boiler to be commissioned and serviced, the boiler is supplied with a combustion test point on the front cleaning door.

When this test point is used please note the following:

- The test point is for CO₂ and smoke readings only.
- The boiler efficiency and temperature must be taken from the flue test point on high level, vertical and conventional flue adaptors.
- Concentric low level flues do not contain a test point. The temperature and efficiency readings must be taken from the flue terminal.

2.4 BOILER DIMENSIONS

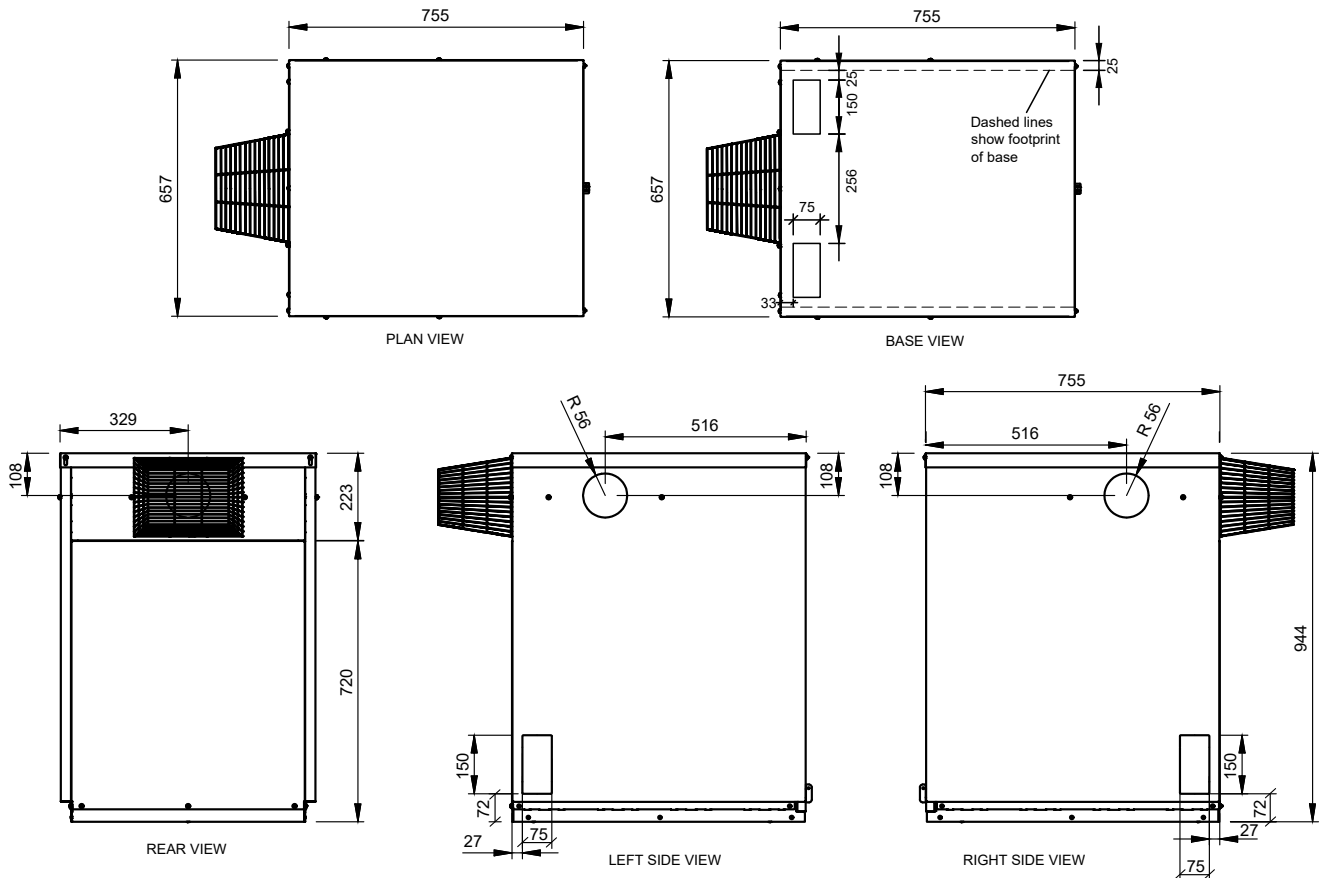

Figure 2-1: Vortex Pro Outdoor Combi Dimensions

3 OIL STORAGE AND SUPPLY SYSTEM

3.1 FUEL SUPPLY

3.1.1 FUEL STORAGE

The tank should be positioned in accordance with the recommendations given in BS 5410-1 (Code of practice for liquid fuel firing. Installations for space heating and hot water supply purposes for domestic buildings). This gives details of the requirements for suitable oil tank construction, tank installation, tank bases, fire protection and secondary containment.

For installations of greater than 70kW output capacity, the tank should be installed in accordance with BS 5410-2.

Oil storage tanks should comply with the following standards:

- Plastic tanks OFT T100
- Steel tanks OFT T200

! CAUTION !

A galvanised tank must not be used.

! NOTE !

Plastic tanks should be stood on a firm non-combustible base that adequately and uniformly supports the weight of the tank over its entire base area.

The tank capacity should be selected to suit the appliance rated output. Refer to BS5410-1 for guidance.

3.1.2 FUEL PIPES

Fuel supply pipes should be either copper or steel. Galvanised pipes or fittings should not be used.

Plastic oil supply pipe conforming to BS EN 14125 can be used for underground pipe runs, but must not be used above ground.

All soft copper pipe connections should preferably be made using flared fittings. If compression fittings are to be used, a suitable pipe insert must be fitted into the pipe end.

Soft soldered connections must NOT be used on oil supply pipework.

Fuel supply pipework should be of a suitable diameter, depending on the type of oil supply system being used. Refer to information given in sections 3.1.3, 3.1.4 or 3.1.5.

Run pipes as level as possible to prevent air being trapped. Take the most direct route possible from tank to burner whilst locating the pipe where it will be protected from damage.

Pipes should be supported to prevent sagging and sleeved where they pass through a wall.

A metal body fuel filter of no better than 70 µm (micron) must be fitted in the oil supply pipe close to the tank. This should be fitted with sufficient clearance around and below it to allow easy access for maintenance.

An isolating valve should also be fitted at the tank, before the filter, to allow the oil supply to be shut off for the filter to be serviced.

A second filter (15 µm for Kerosene) must be located closer to the burner to protect the burner pump and nozzle from contamination. Refer to Figures 3-1 to 3-3.

A remote sensing fire valve must be installed in the fuel supply line in accordance with BS5410-1.

A fusible wheelhead type combined isolating/fire valve MUST NOT be used in place of a remote sensing fire valve.

The fire valve must be located externally to the appliance casing, with the fire valve sensor located above the burner.

A spring clip for mounting the sensor is supplied fitted to the boiler, on the rear of the control panel.

The fire valve should be located after the second (15 micron) filter, i.e. between the filter and the point at which the oil line enters the appliance casing. Refer to Figures 3-1 to 3-3.

The fire valve must have an operating temperature of between 90 and 95°C to avoid unnecessary nuisance shut-offs to the oil supply.

A flexible fuel hose and ¼" isolating valve are supplied loose with the boiler, to make the final connection to the burner.

If a two-pipe system or deaerator is to be used, the following additional items will be required:

- Flexible fuel hose ¾" male x ¼" female (product code: RBS36 - 900 mm / product code: RBS36XS - 600mm)
- ¾" x ¼" BSP adaptor (product code: Z3003602)
- ¼" isolating valve (product code: ISOLATION1/4)

These are available to purchase from Grant UK.

Metal braided flexible fuel hoses should be replaced ANNUALLY when the boiler is serviced.

Long life flexible fuel hoses should be inspected annually and replaced, if necessary, or after a maximum five years service life.

3.1.3 SINGLE PIPE (GRAVITY) SYSTEM - (REFER TO FIGURE 3-1)

Head A (m)	Maximum pipe run (m)	
	10 mm OD pipe	12 mm OD pipe
0.5	10	20
1.0	20	40
1.5	40	80
2.0	60	100

If the storage tank outlet is at least 300 mm above the level of the burner oil pump, a single pipe (gravity) system should be used.

The maximum height of the oil level above the burner oil pump when the tank is full, must not exceed four metres. If this height is exceeded, a pressure reducing valve must be fitted in the oil supply pipe between the tank and the burner oil pump.

The maximum length of pipe run from the tank to the burner is limited by the minimum head of oil (the height of the tank outlet above the burner oil pump).

3.1.4 TWO PIPE SYSTEM - (REFER TO FIGURE 3-2)

Head A (m)	Maximum pipe run (m)	
	10 mm OD pipe	12 mm OD pipe
0	35	100
0.5	30	100
1.0	25	100
1.5	20	90
2.0	15	70
3.0	8	30
3.5	6	20

If the storage tank outlet is below the level of the burner oil pump, a two pipe (sub gravity) system can be used.

The return pipe should be at the same level as the tank outlet, between 75 to 100 mm above the base of the tank. The return pipe should be a sufficient distance from the tank outlet so as to prevent any sediment disturbed by the return entering the supply pipe from the tank.

A non-return valve should be fitted in the supply pipe, along with a fire valve and filters (refer to section 3.1.2 - fuel pipes). A non-return valve should also be fitted in the return pipe if the top of the tank is above the burner oil pump.

The maximum suction height (from the tank outlet to the level of the burner oil pump), must not exceed 3.5 metres.

The pump vacuum should not exceed 0.4 bar. Beyond this limit, gas is released from the oil.

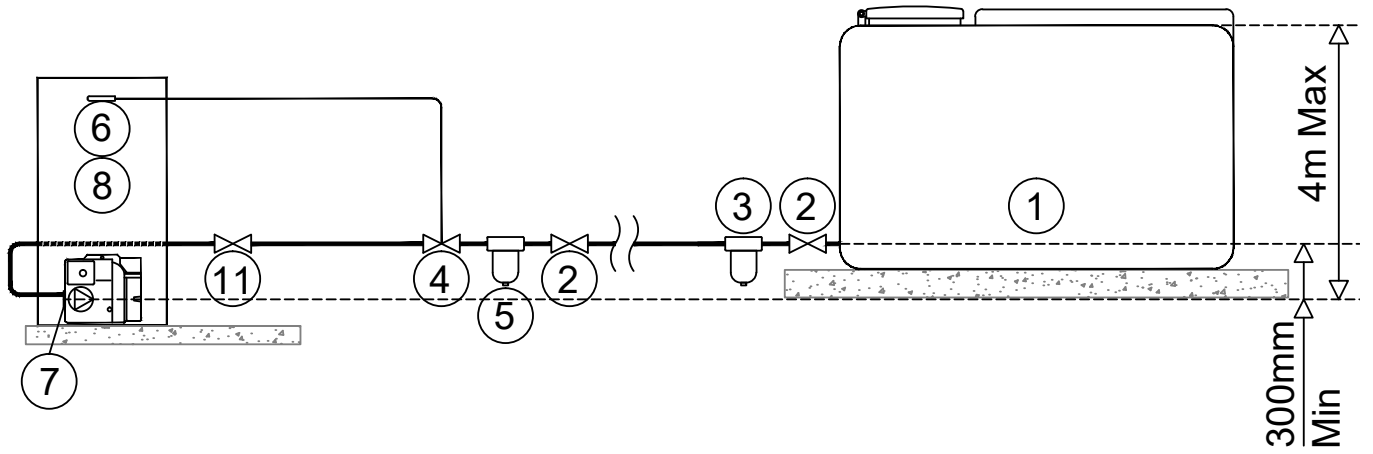

Figure 3-1: Single pipe (gravity) system

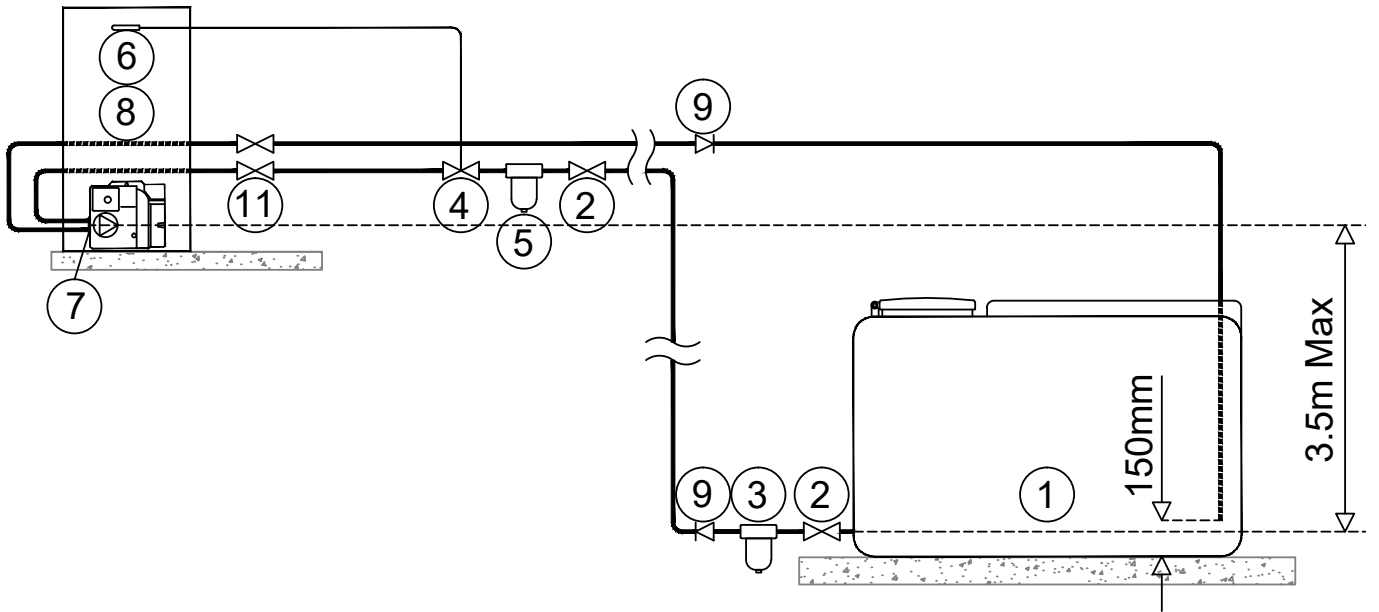

Figure 3-2: Two pipe system

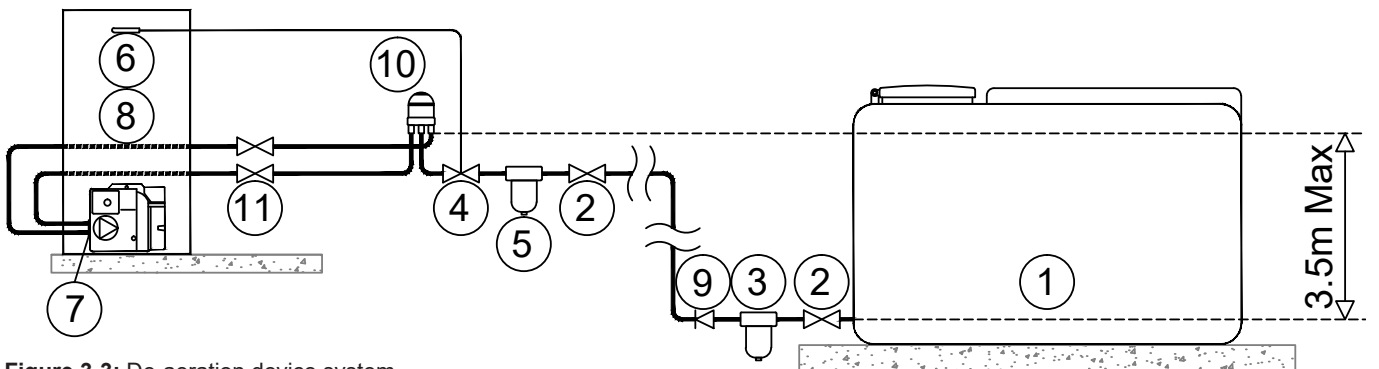

Figure 3-3: De-aeration device system

Key to oil supply diagrams

1	Oil tank	5	Oil filter (15µm max. filtration size)	9	Non-return valve
2	Isolating valve	6	Fire valve sensor	10	De-aerator*
3	Oil strainer	7	Oil pump	11	Appliance isolation valves
4	Fire valve to BS5410-1	8	Burner		

* Position of de-aeration device must be level with or above the oil pump

For guidance on the installation of top outlet fuel tanks and suction oil supply pipe sizing, refer to OFTEC Technical Book 3: Storage and Supply, available for purchase from OFTEC.

If a two-pipe system is to be used, the following additional items will be required:

- Flexible fuel hose 3/8" male x 1/4" female (product code: RBS36 - 900 mm / product code: RBS36XS - 600mm)
- 3/8" x 1/4" BSP adaptor (product code: Z3003602)
- 1/4" isolating valve (product code: ISOLATION1/4)

These are available to purchase from Grant UK.

3.1.5 SINGLE PIPE (SUCTION) SYSTEM WITH DEAERATOR - (REFER TO FIGURE 3-3)

If the storage tank outlet is below the level of the burner oil pump, an alternative to the two pipe (sub gravity) system is the single pipe (suction) system using a deaerator, e.g. a 'Tiger Loop' device.

The deaerator creates a loop with the burner oil pump, with the oil being circulated through the pump out to the deaerator and back to the pump. Any air in the single pipe lift from the tank is removed from the oil, collected in the deaerator and then discharged to outside.

! WARNING !

To prevent any fuel vapour being discharged within the building, the deaerator must be fitted outside, in accordance with BS 5410-1, unless it is specifically designed to be installed inside.

The de-aerator must be mounted vertically at the same level as (or above) the burner oil pump. Refer to Figure 3-3.

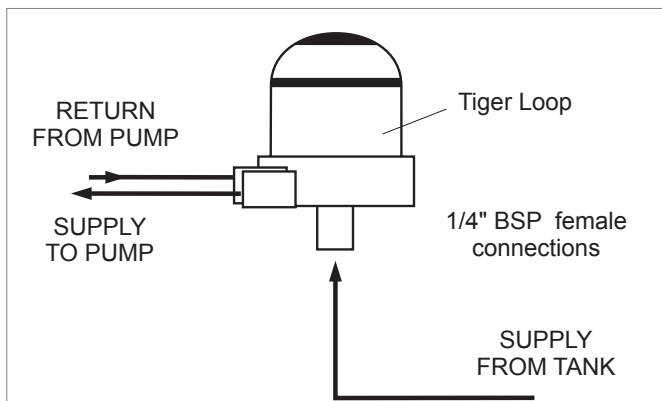

Figure 3-4: Tiger loop de-aeration device

An external deaerator must not be fitted within 500 mm of a flue terminal.

Always follow the manufacturers installation instructions supplied with the deaerator.

To use a de-aerator, the following additional items will be required:

- Flexible fuel hose 3/8" male x 1/4" female (product code: RBS36 - 900 mm / product code: RBS36XS - 600mm)
- 3/8" x 1/4" BSP adaptor (product code: Z3003602)
- 1/4" isolating valve (product code: ISOLATION1/4)

These are available to purchase from Grant UK.

3.2 BURNER OIL CONNECTION

! WARNING !

The blanking plug supplied in the inlet (suction) port is plastic and will not provide an oil tight seal when the pump is running.

Ensure that the supply from the tank is connected to this port and that the plastic plug is discarded.

The burner fuel pump is supplied factory set for use with a single pipe (gravity) oil supply system.

For ease of access to the burner oil pump connections, the burner should be removed from the boiler as follows:

1. Remove the red plastic burner cover.
 - Unscrew and remove the TWO fixing screws from the red burner cover and remove the cover from the burner.
2. Unscrew and remove the single burner fixing nut from the stud on the burner flange (at the top of the burner) using a 13 mm spanner. Retain the fixing nut for re-fitting the burner.
3. Carefully withdraw the burner from the boiler.

3.2.1 SINGLE PIPE (GRAVITY) CONNECTION - REFER TO FIGURE 3-5

Connect the oil supply to the burner oil pump as follows:

1. Unscrew and remove the plastic blanking plug from the suction port of the burner oil pump and discard it.
2. Fit the nut of the elbow connection on the flexible fuel hose (supplied with the boiler) into the suction port and tighten.
3. Fit the 1/4" isolating valve (supplied with the boiler) to the end of the rigid oil supply pipe using a fitting to suit the pipe size and type (not supplied).
4. Connect the other end of the flexible fuel hose to the isolating valve using the 3/8" x 1/4" BSP adaptor (supplied with the boiler).
5. Re-fit the burner to the boiler.

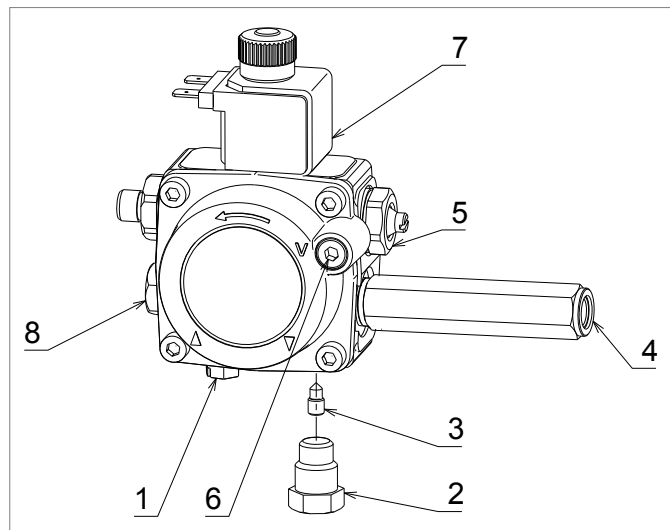

Figure 3-5: Riello oil pump

Item	Description
1	Inlet (suction) port
2	Return port
3	By-pass screw
4	Pressure gauge port
5	Pressure adjustment
6	Vacuum gauge port
7	Solenoid
8	Auxiliary pressure test point

3.2.2 TWO PIPE CONNECTION

For either a two pipe (sub gravity) or a single pipe (suction) system with a deaerator, the following additional items will be required:

- Flexible fuel hose 3/8" male x 1/4" female (product code: RBS36 - 900 mm / product code: RBS36XS - 600mm)
- 3/8" x 1/4" BSP adaptor (product code: Z3003602)
- 1/4" isolating valve (product code: ISOLATION1/4)

These are available to purchase from Grant UK.

Connect the oil supply to the burner oil pump as follows:

1. Fit the flexible fuel hose (supplied with the boiler) to the suction port of the burner oil pump, as detailed in Section 3.2.1.

With either a two pipe (sub gravity) system or a single pipe (suction) system with a deaerator, the by-pass screw (supplied with the boiler) must be fitted to the burner oil pump as follows:

1. Unscrew and remove the blanking plug from the return port on the burner oil pump and discard it.
2. Fit the by-pass screw into the threaded hole (inside the return port) and fully screw it in using an Allen key.
3. Fit the nut of the elbow connection on the flexible fuel hose into the return port and tighten.
4. Fit the 1/4" isolating valve (not supplied) to the end of the rigid oil return pipe (to the deaerator or oil tank) using a fitting to suit the pipe size and type (not supplied).
5. Connect the other end of the flexible fuel hose (not supplied) to the isolating valve using a 3/8" x 1/4" BSP adaptor (not supplied).
6. Re-fit the burner to the boiler.

4 INSTALLATION

4.1 INTRODUCTION

The boiler is supplied already fully assembled, with the flue terminal guard loose inside the boiler, in a carton which is carefully packed with packing materials. The installation procedure therefore begins with unpacking of the packed boiler.

4.2 BOILER LOCATION

The External module must stand on a firm and level surface capable of supporting the boiler when full of water. Refer to Section 2.1 for weights.

It does not require a special hearth as the temperature of the boiler base is less than 50°C.

The module can be installed either against the building, or 'free standing' some distance away from the building.

Sufficient clearance must be allowed at the front of the boiler to remove the burner and baffles for servicing, clearance must also be left at the top of the module to allow removal of the top panel.

Adequate clearance is also required at the rear of the module, to allow removal of the back panel for access to the condensate trap.

4.3 REGULATIONS COMPLIANCE

! NOTE !

Failure to install and commission appliances correctly may invalidate the boiler guarantee.

Installation of a Grant Vortex boiler must be in accordance with the following recommendations:

- Building Regulations for England and Wales, and the Building Standards for Scotland issued by the Department of the Environment and any local Byelaws which you must check with the local authority for the area.
 - Model and local Water Undertaking Byelaws.
 - Applicable Control of Pollution Regulations.
 - National Building Regulations and any local Byelaws.
 - Model Byelaws and the Water Supply Regulations.
 - The following OFTEC requirements:
 - OFS T100 Polythene oil storage tanks for distillate fuels.
 - OFS T200 Fuel oil storage tanks and tank bunds for use with distillate fuels, lubrication oils and waste oils.
- Further information may be obtained from the OFTEC Technical Book 3 (Installation requirements for oil storage tanks) and OFTEC Technical Book 4 (Installation requirements for oil fired boilers).

The installation should also be in accordance with the latest edition of the following British Standard Codes of Practice (and any relevant amendments):

- BS 5410-1: 2019 (Code of practice for liquid fuel firing. Installations for space heating and hot water supply purposes for domestic buildings)
 - This standard covers domestic installations up to 70kW.
- BS 5410-2: 2018 (Code of practice for liquid fuel firing. Non-domestic installations)
 - This standard should be followed with regard to installations with an output capacity in excess of 70kW.
 - Where the combined outputs of multiple appliances located together at a domestic dwelling exceed 70kW then then a dedicated plant room as specified in BS 5410-2 is recommended.
- BS EN 12828 (Heating systems in buildings. Design for water-based heating systems)
- BS EN 12831-1 (Energy performance of buildings. Method for calculation of the design heat load)
- BS EN 14336 (Heating systems in buildings. Installation and commissioning of water based heating systems)

- BS 7593 (Code of Practice for treatment of water in domestic hot water central heating systems)
- BS 7671 (Requirements for Electrical installations, IET Wiring Regulations)
- BS 7291 (Thermoplastics pipe and fitting systems for hot and cold water for domestic purposes and heating installations in buildings. General requirements)
- BS 7074-1 (Application, selection and installation of expansion vessels and ancillary equipment for sealed water systems. Code of practice for domestic heating and hot water supply)
- BS 2869 (Fuel oils for agricultural, domestic and industrial engines and boilers. Specification)

! WARNING !

BS5410-1: 2019 requires that appliances located in a building or structure or within a restricted area externally should have a CO detector conforming to BS EN 50291-1 installed in the same room/space.

4.4 HEATING SYSTEM DESIGN CONSIDERATIONS

! WARNING !

Before starting any work on the boiler or fuel supply, please read the Health and Safety information given in Section 15.

To achieve the maximum efficiency possible from the Grant Vortex boiler, the heating system should be designed to the following parameters:

RADIATORS:

- Flow temperature 70°C
- Return temperature 50°C
- Differential 20°C

Size radiators with a mean water temperature of 60°C.

Design system controls with programmable room thermostats or use weather compensating controls to maintain return temperatures below 55°C.

! NOTE !

The boiler should not be allowed to operate with return temperatures of less than 40°C when the system is up to temperature.

The use of a pipe thermostat is recommended to control the return temperature when using weather compensating controls.

UNDERFLOOR:

- Flow temperature 50°C
- Return temperature 40°C
- Differential 10°C

In underfloor systems, it is essential that the return temperature must be maintained at or above 40°C to prevent internal corrosion of the boiler water jacket.

Refer to Table 2-1 for the size and type of the connections and Section 5 for the position of the connections.

4.5 PIPEWORK MATERIALS

The Grant Vortex boiler is compatible with both copper and plastic pipe. Where plastic pipe is used it must be of the oxygen barrier type and be the correct class (to BS 7291-1) for the application concerned.

On either sealed or open-vented systems; where plastic pipe is used a minimum of ONE metre of copper pipe (or as per pipe manufacturers instructions) MUST be connected between both the boiler flow and return connections and the plastic pipe.

! NOTE !

Do not connect plastic pipe directly to the boiler.

Grant UK does not accept any responsibility for any damage, however caused, to plastic piping or fittings.

SEALED SYSTEMS

If plastic pipe is to be used, the installer must check with the plastic pipe manufacturer that the pipe to be used is suitable for the temperature and pressures concerned.

Plastic pipe must be Class S to BS 7291-1.

! WARNING !

When plastic pipe is used, the system MUST incorporate a low pressure switch to shut off power to the boiler if the system pressure drops below 0.2 bar. A suitable low pressure switch kit is available to purchase from Grant UK (product code: MPCBS62).

UNDERFLOOR PIPEWORK

Plastic pipe may be used on underfloor floor systems where the plastic pipe is fitted after the thermostatic mixing valve. Copper tube must be used for at least the first metre of flow and return primary pipework between the boiler and the underfloor mixing/blending valves.

4.6 CONNECTIONS

4.6.1 FLOW, RETURN AND HOT WATER CONNECTIONS

Refer to Section 5.

4.6.2 CONDENSATE CONNECTION

Grant Vortex Outdoor Combi boilers are supplied with a factory-fitted condensate trap to provide the required 75 mm water seal in the condensate discharge pipe from the boiler.

Refer to Section 6 for details of the condensate disposal pipework.

4.6.3 DRAIN COCK

A drain cock is fitted at the bottom on the front of the boiler to allow the heating system to be drained.

There is also a drain cock fitted at the bottom on the front of the primary store.

4.7 PREPARATION FOR INSTALLATION

1. Carefully remove the packaging from the boiler and remove it from the transit pallet.
2. Remove the case top panel (four screws) and also the front and rear panels as required.
3. The flue may exit the boiler from the left, right or rear of the casing. Carefully press out the pre-cut section on the side or rear casing panel to provide the opening in the required position for the flue to pass through the casing.

Fit the cover panel (with the round flue exit hole) over the chosen opening in the casing. Fit the circular rubber sealing grommet provided into the circular hole in the cover panel before fitting the flue terminal section (or first flue extension if the flue is being extended using the green system).

4. Slacken the wing nuts holding the starter elbow and rotate the elbow to the required direction for the flue to exit the casing.
5. Push the end of the flue terminal section or flue extension (with the red seal) from the outside of the boiler casing through the sealing grommet in the casing panel. The terminal section has been factory lubricated. Take care not to dislodge or damage the red flue seal.

If using the low level flue option provided with the boiler:

6. Carefully insert the terminal into the starter elbow until the bend of the terminal contacts the outer casing, then pull the terminal forward approximately 25mm and rotate the bend so that the outlet is **horizontal**.

Rear Exit - The flue must discharge away from the building.

Side Exit - The flue should discharge towards the rear of the casing to prevent flue gases re-entering the boiler casing through the air inlet vents on the casing door.

The flue terminal must be fitted horizontally to prevent dripping from the end of the terminal.

If you are planning to extend the flue before terminating:

7. Carefully insert the first extension/elbow piece into the starter elbow and secure with a locking band.
8. Tighten the wing nuts holding the starter elbow and fit the stainless steel flue guard (if using low level flue option provided with boiler) using the two screws provided.
9. The top panel of the casing has been designed so that it may be fitted to create a slight slope away from the side positioned against the wall. To tilt the top panel, loosen the four top panel casing screws and push down on the side furthest from the wall. Tighten the screws. See Figure 4-1.

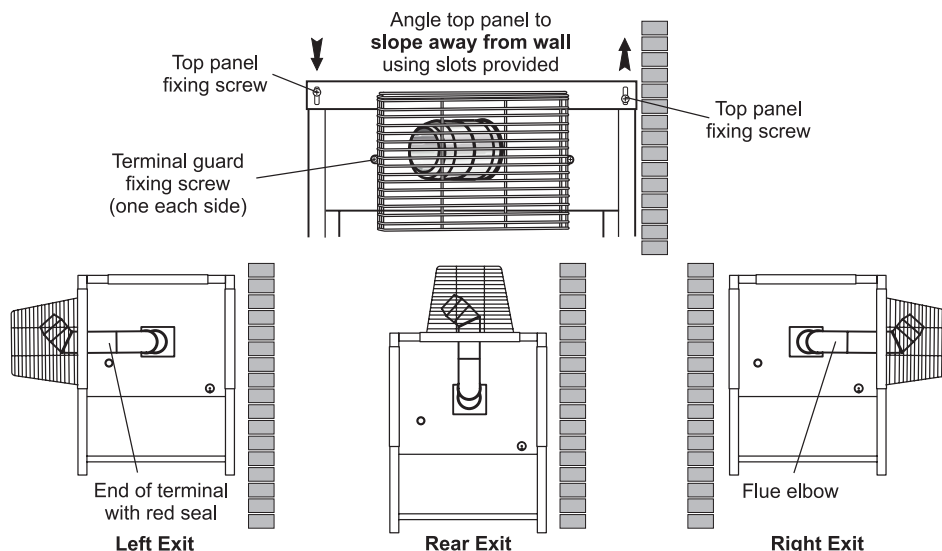

Figure 4-1: Standard low level flue provided with Outdoor Module

4.8 INSTALLING THE BOILER

1. If the boiler is to be fitted against a wall, prepare the wall to accept the heating system pipework. To mark the wall for drilling, refer to Section 2.4 for the positions of the pipework openings in the enclosure sides.

! NOTE !

Pipework should be insulated where it passes through the wall into the boiler enclosure.

If the boiler is to be installed 'free standing' (i.e. away from a wall) and the pipework run underground, push out the 'knock-outs' to open the required pipe openings in the base of the boiler enclosure. Using a sharp knife, cut through the polystyrene in the base, around the edge of the holes, to allow the flow and return pipes to enter the enclosure.

2. The electrical supply to the boiler should be routed through the wall in a suitable conduit, such that it enters the boiler enclosure via one of the unused pipework openings. The cable can be routed to the front of the boiler, for connection to the boiler control panel, either over the top or beneath the boiler heat exchanger. Heat resistant PVC cable, of at least 0.75mm² cross section should be used within the boiler enclosure. Refer to Section 8 for further information regarding the electrical side of the installation process.

! NOTE !

Pipework and cables can be routed into the enclosure via one of the unused flue exit holes by using a section of 110mm soil pipe as ducting through the wall. The flue exit holes in the boiler casing are sized to accept 110mm soil pipe.

3. The oil supply line should be installed up to the position of the boiler. Refer to section 3.1 for details. The final connection into the boiler enclosure can be made with 10mm soft copper, routed along the base of the enclosure (either between the enclosure and wall or in front of the enclosure) to enter through one of the holes located in the bottom edge side panel, at the front (burner) end.
4. Connect the power supply as described in Section 8.
5. Ensure the flue terminal position complies with the necessary clearances outlined in Section 9.

4.9 EXPANSION VESSEL

The Combi 21, Combi 26 and Combi 36 models are supplied with a 24 litre expansion vessel located in the front of the boiler.

Should it be required, the expansion vessel can be relocated. If this option is chosen, the vessel must be connected to the heating system by using a suitable fitting (not supplied), via the flexible hose, in a convenient position where it can be readily accessed for servicing.

The expansion vessel fitted is supplied with a charge pressure of 1.0 bar (equivalent to a maximum static head of 10.2 metres). The charge pressure must not be less than the actual static head at the point of connection.

Do not pressurise the vessel above 1.5 bar.

! NOTE !

The air pressure in the vessel must be checked annually. The central heating system volume, using the expansion vessel as supplied, must not exceed the recommended volumes. Refer to Section 2.1. If the system volume is greater, an extra expansion vessel (complying with BS 4841) must be fitted as close as possible to the central heating return connection on the boiler. The charge pressure of the extra vessel must be the same as the vessel fitted in the boiler.

Refer to BS 7074-1 for further guidance.

The air charge pressure may be checked using a tyre pressure gauge on the expansion vessel Schraeder valve.

The vessel may be re-pressurised using a suitable pump. When checking the air pressure the water in the heating system must be cold and the system pressure reduced to zero.

4.10 FILLING THE HEATING SYSTEM

Refer to Section 7.2 (Filling the Sealed System).

4.11 BEFORE YOU COMMISSION

To avoid the danger of dirt and foreign matter entering the boiler the complete heating system should be thoroughly flushed out – both before the boiler is connected and then again after the system has been heated and is still hot. This is especially important where the boiler is to be installed on an older system.

For optimum performance after installation, the boiler and the associated heating system must be flushed in accordance with the guidelines given in BS 7593 (Treatment of water in domestic hot water central heating systems). This must involve the use of a proprietary cleaner, such as Sentinel X300 (new systems), Sentinel X400 (existing systems), or Fernox Restorer.

After cleaning, it is vitally important that all traces of the cleaner are thoroughly flushed from the system.

For long term protection against corrosion and scale, after cleaning/flushing a suitable inhibitor should be added to the system water, such as Sentinel X100 or Fernox MB-1, in accordance with the manufacturers' instructions.

Failure to follow the above will invalidate the guarantee.

If the boiler is installed in a garage, out house or outside, in order to provide further protection should there be a power failure in cold weather, a combined anti-freeze and corrosion inhibitor can be used such as Sentinel X500 or Fernox Alpha-11. Follow the manufacturers' instructions supplied to achieve the level of anti-freeze protection required.

For details of the Sentinel Products visit www.sentinel-solutions.net and for Fernox products visit www.fernox.com.

Grant UK strongly recommends that a Grant Mag One in-line magnetic filter/s (or equivalent*) is fitted in the heating system pipework. This should be installed and regularly serviced in accordance with the filter manufacturer's instructions.

* As measured by gauss. The MagOne magnetic filter has a gauss value of 12000.

4.12 COMPLETION

Following installation of the boiler, instruct the user in the operation of the boiler, the boiler controls, the heating controls and the safety devices.

Please ensure that the OFTEC CD/10 installation completion report (provided with the boiler) is completed in full, leaving the top copy with the user and retain the carbon copy for your own records.

Ensure that the User Handbook (supplied with the boiler) is handed over to the user.

5 PIPE CONNECTIONS

5.1 WATER CONNECTIONS

The flow and return pipework can exit the boiler enclosure either through the pre-cut openings provided in both sides (under the movable cover plates) and through the wall when installed against the building, down and through the pre-cut openings provided in the base of the enclosure for 'free standing' installations, or through an unused side flue exit opening (a spare blanking plate with a 112mm diameter hole is supplied, which is intended to provide an opening for a 110mm soil pipe to be used as a pipe duct through the wall). See Section 2.4.

Push out the 'knock-out' from the required holes, taking care not to distort the side panel or base.

For condensate disposal pipework refer to Section 6.

- To gain access to the water connections, remove the two screws securing the back panel and remove it by withdrawing it forwards at the bottom. Remove the top casing panel, see Section 4.7 and Figure 4-1.
- Carefully manoeuvre the boiler in position to line up with pipework through the wall. Complete the water connections. **Note:** Check that the baffles are in position and that the cleaning cover is correctly fitted and a good seal made.
- Fit the flue starter elbow in the chosen position. This should be done at this point to ensure the starter elbow will not conflict with any of the pipework. Refer to Sections 4.7 and 9.

- If the boiler is installed against a wall, fit the wall flashing strip. Position the strip with the bottom edge of the wider flange 20 mm above the enclosure top panel, with the narrow flange (with the three fixing holes) flat against the wall. The strip should overhang the top panel by an equal amount at each end.
- Mark the position of the three fixing holes onto the wall, drill and plug the wall and secure the strip with suitable screws (not supplied).

FLOW AND RETURN CONNECTIONS

All models are supplied with a push-fit elbow connection for the heating flow and return - 22mm (Vortex Pro Combi 21 and 26) or 28mm (Vortex Pro Combi 36).

HOT WATER CONNECTIONS

All models are supplied with push-fit elbow connections for the cold water mains inlet pipe and hot water outlet pipe. These are 15mm for the Vortex Pro Combi 21 and 26, and 22mm for the Vortex Pro Combi 36.

! CAUTION !

All pipes to be fitted into the push-fit connectors provided should be cut using a pipe slicer or pipe cutter - to leave the pipe ends with a slight radius and free from any burrs or sharp edges. Pipes to be used with these fittings should not be cut square using a hacksaw.

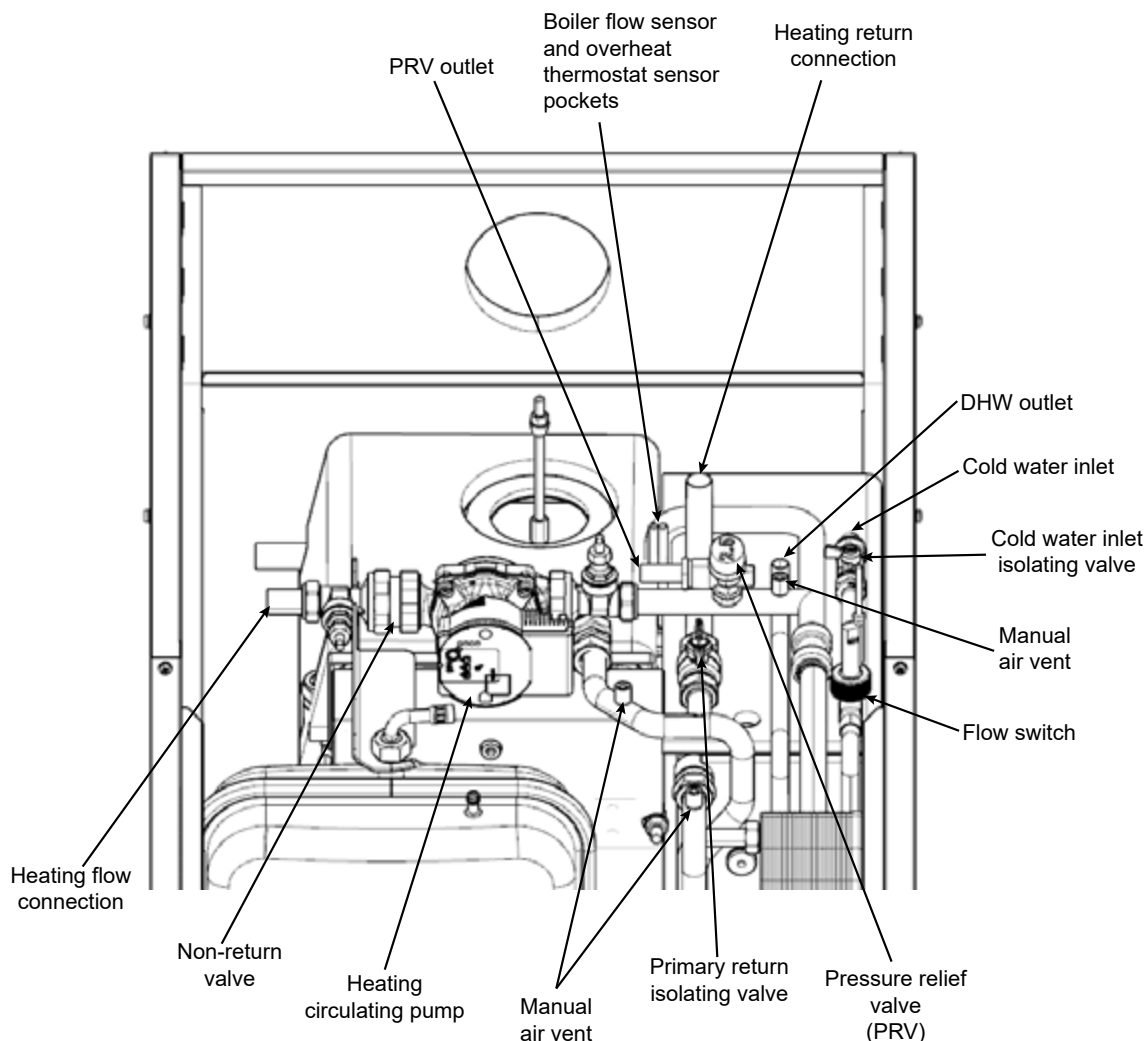

Figure 5-1: Vortex Pro Outdoor Combi Pipe Positions

ALL MODELS

A 15 mm discharge pipe must be connected to the safety valve outlet connection. The pipework between the safety valve and the boiler must be unrestricted, that is, no valves. The discharge pipe should be run to the outside of the building and terminate so that it cannot cause injury to persons or property.

A drain tap is provided at the bottom on the front of the boiler (and also on the hot water store on the Vortex Pro Combi).

5.2 MAKING THE WATER CONNECTIONS

Flow and return pipework can be routed to either side of the boiler (dependant on the flue system used and where it exits the boiler) or can be routed through the base of the enclosure, from the push-fit elbows (supplied) on the flow and return connections. Refer to Figure 5-1 for flow and return pipework positions.

Holes are provided in the rear of the casing side panels to allow the condensate pipe to be run through the back of the boiler. It will be necessary to remove the back panel from the boiler casing to fit this pipework, and to refit the panel before placing the boiler in its final position. Refer to Figures 6-2 & 6-3.

If access will be restricted, make any connections to the boiler before placing it in its final position.

5.3 DOMESTIC HOT WATER SYSTEM

To maintain a longer and more consistent hot water temperature, a flow restrictor is factory fitted to the Vortex Pro Combi 21 to limit the flow rate to approximately 12 litres/minute, and to the Vortex Pro Combi 26 to limit the flow rate to approximately 15 litres/minute.

The flow restrictor is located in the outlet side of the cold water inlet isolating valve.

A flow restrictor is not fitted to the Vortex Pro Combi 36.

The incoming mains water pressure should be between 1 and 8 bar to ensure efficient operation.

! NOTE !

If the pressure is above 8 bar a pressure reducing valve must be fitted.

The boiler may still operate down to a pressure of 1.0 bar but with a reduced flow rate. The minimum flow rate needed for the flow switch to operate is 3 litres/minute.

To ensure economic use, the pipe runs between the boiler and hot taps should be as short as possible and in 15 mm copper pipe or 22 mm for the Vortex Pro Combi 36 only. Where possible the pipework should be insulated to reduce heat loss.

All taps and mixing valves used in the domestic hot water system must be suitable for operating at a mains pressure of up to 8 bar.

If required, a shower may be fitted in the domestic hot water system. It is recommended that thermostatically controlled shower valves are used to protect against a flow of water at too high a temperature. If a fixed head type shower is used, no anti-siphonage devices are required. If a loose or flexible head type shower is used, it must be arranged so that the head cannot fall closer than 25 mm above the top of the bath, thereby preventing immersion in the bath water. If this is not practicable, an anti-siphonage device must be fitted at the point of the flexible hose connection.

The supply of hot and cold mains water direct to a bidet is allowed (subject to local Water Undertaking requirements) provided that the bidet is of the overrim flushing type. The outlets should be shrouded and unable to have a temporary hand held spray attached. Arrangements for antisiphonage are not necessary.

Before the mains water supply pipe is connected to the boiler, it should be thoroughly flushed out to avoid the danger of dirt or foreign matter entering the boiler.

The mains water connection to the boiler must be the first connection from the mains supply.

5.4 TO USE THE WATER HARDNESS KIT

! NOTE !

A water hardness test kit is supplied with the boiler. Should the total hardness of the water supply exceed 125 ppm, an in-line scale inhibitor should be fitted in the cold water supply to the boiler.

Consult the local Water Undertaking if in doubt.

Do not immerse the test strip in running water and avoid contact.

1. Fill a clean container with a sample of water from the mains cold water supply to the boiler.
2. Immerse the test strip in the water for approximately one second, ensuring that all the test zones are fully wetted.
3. Shake off the surplus water and wait for one minute.
4. Assess the colouration of the test zones using the following chart.

Table 5-1: Key to water hardness

Green areas	Violet areas	Hardness	Total hardness mg/l (ppm)
4	0	Very soft	<50 mg/l calcium carbonate
3	1	Soft	<70 mg/l calcium carbonate
2	2	Medium	<125 mg/l calcium carbonate
1	3	Hard	<250 mg/l calcium carbonate
0	4	Very hard	<370 mg/l calcium carbonate

Note: 1mg/l = 1 ppm (part per million)

If the hardness reading is found to be in the medium to very hard range (the shaded area), it is essential that some form of water conditioner or softener is fitted to reduce scale formation within the combination boiler. Failure to do so may invalidate both the manufacturers guarantee and any extended guarantee covering the appliance.

The water conditioner or softener should be fitted to the cold water supply serving the appliance and in accordance with the manufacturer's instructions. Grant UK cannot be held responsible for any damage or misuse caused by the fitting of any water conditioning device.

! CAUTION !

Please protect the domestic hot water system from harmful effects of scale. Problems caused by the build-up of limescale are not covered under the terms of the guarantee.

6 CONDENSATE DISPOSAL

6.1 GENERAL REQUIREMENTS

When in condensing mode the Grant Vortex boilers produce condensate from the water vapour in the flue gases.

This condensate is moderately acidic with a pH value of around 3.27 (similar to orange juice).

Provision must be made for the safe and effective disposal of this condensate.

Condensate can be disposed of using one of the following methods of connection:

Internal connection (preferred option)

- into an internal domestic waste system (from kitchen sink, washing machine, etc.)
- directly into the soil stack

External connection

- into an external soil stack
- into an external drain or gully
- into a rainwater hopper (that is part of a combined system where sewer carries both rainwater and foul water)
- purpose made soakaway

All condensate disposal pipes **must** be fitted with a trap - whether they are connected internally or externally to a domestic waste system/soil stack or run externally to a gully, hopper or soakaway.

6.2 CONNECTIONS

Connections into a rainwater hopper, external drain or gully should be terminated inside the hopper/drain/gully below the grid level but above the water level.

! CAUTION !

Condensate disposal pipes must not be connected directly into rainwater downpipes or to waste/soil systems connected to septic tanks.

Condensate should not be discharged into 'grey water' systems that re-use water used in the home (not including water from toilets).

It should be noted that connection of a condensate pipe to the drain may be subject to local Building Control requirements.

6.3 PIPEWORK

Condensate disposal pipework must be plastic (plastic waste or overflow pipe is suitable).

! NOTE !

Copper or steel pipe is NOT suitable and MUST NOT be used.

Condensate disposal pipes should have a minimum 'nominal' diameter of 22 mm (¾") - e.g. use 21.5 mm OD polypropylene overflow pipe.

Condensate disposal pipes must be fitted with a fall (away from the boiler) of at least 2.5° (~45 mm fall per metre run).

! NOTE !

Where it is not possible for the pipe to fall towards the point of discharge - either internally into a waste system or externally to a gully (e.g. for boilers installed in a basement), it will be necessary to use a condensate pump.

Condensate disposal pipes should be kept as short as possible and the number of bends kept to a minimum.

Pipes should be adequately fixed to prevent sagging, i.e. at no more than 0.5 metre intervals.

6.4 EXTERNAL PIPEWORK

Ideally, external pipework, or pipework in unheated areas, should be avoided. If unavoidable, external pipework should be kept as short as possible (less than 3 metres) and 32 mm waste pipe used to minimise the risk of ice blocking the pipe in freezing conditions.

The number of bends, fittings and joints on external pipes should be kept to a minimum to reduce the risk of trapping condensate.

! NOTE !

For boilers installed in an unheated area such as a loft, basement, outhouse or garage, all condensate pipework should be as 'external'.

The pipework should be insulated using suitable waterproof and weather resistant insulation.

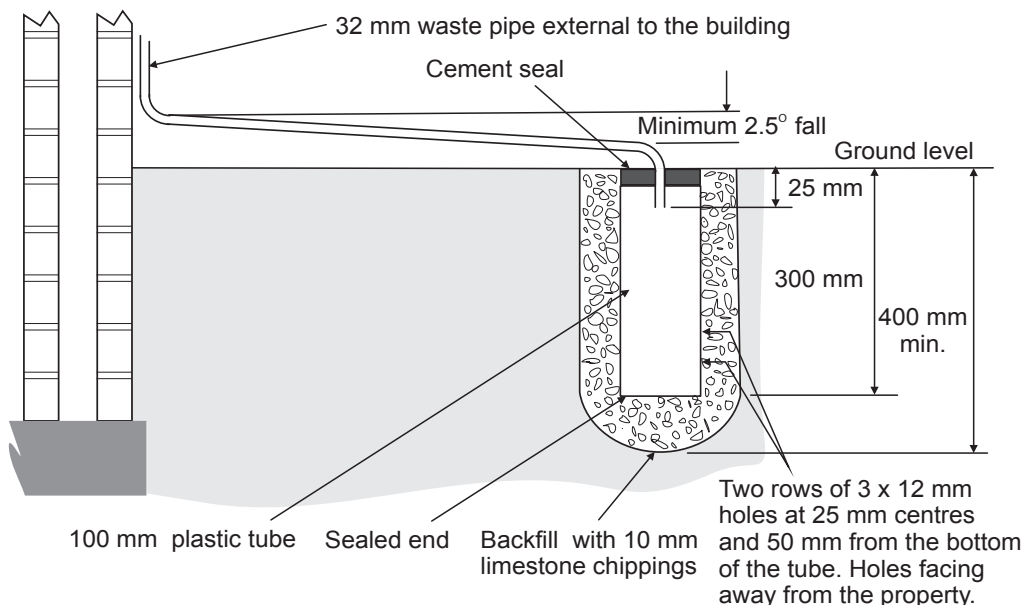

Figure 6-1: Purpose made condensate soakaway

6.5 CONDENSATE SOAKAWAY

To keep external pipework to a minimum, locate the soakaway as close as possible to the boiler but ensure it is at least 500 mm from building foundations and away from other services, e.g. gas, electricity, etc.

The condensate pipe may be run above or below ground level and can enter either the top or side of the soakaway tube. Refer to Figure 6-1.

Ensure that the drainage holes in the soakaway tube face away from the building.

Backfill both the soakaway tube, and the hole around it, with 10 mm limestone chippings.

Only use a soakaway where the soil is porous and drains easily. Do not use in clay soils or where the soil is poorly drained.

! CAUTION !

Any damage due to condensate backing up into the boiler due to a high water table, in the case of a soakaway, or flooded drains when the condensate disposal is via a gully or soil stack, is not covered by the Grant product guarantee.

6.6 CONDENSATE TRAP

Grant Vortex boilers are supplied with a condensate trap to provide the required 75 mm water seal in the condensate discharge pipe from the boiler.

The condensate trap is factory fitted inside the boiler casing - mounted on the inside of the left hand side panel at the rear of the boiler - in an accessible position to allow for routine maintenance, see Figure 6-2.

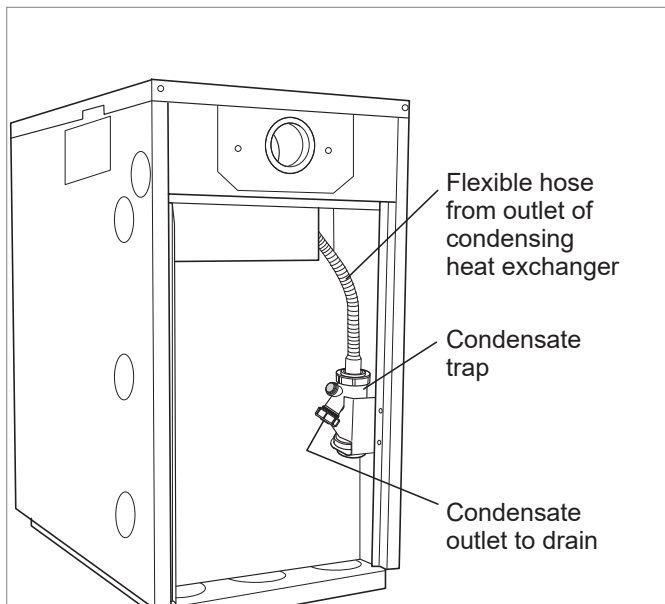

Figure 6-2: Condensate trap location

This trap incorporates a float (which will create a seal when the trap is empty) and an overflow warning outlet (fitted with a plastic sealing cap), see Figure 6-3.

! NOTE !

Access must be available to allow for routine maintenance.

A flexible hose connects the outlet of the condensing heat exchanger to the trap inlet. Ensure the elbow connector on the hose is fully pushed onto the 'top hat' inlet connector of the trap.

With the trap fitted inside the boiler casing, the sealing cap must be fitted. If the trap is re-located outside the boiler, then the following applies:

- If connecting the condensate discharge - either internally or externally - into a waste system or soil stack - the sealing cap must be fitted in the trap outlet.
- On external discharge systems to a hopper, gully or soakaway, the sealing cap should be removed from the trap outlet.
- If there is any discharge of condensate from the overflow outlet, this could indicate a blockage (possibly due to freezing). Turn off the boiler and investigate the cause. If necessary contact your service engineer for assistance.

! WARNING !

Care should be taken when siting the trap such that the overflow outlet is readily visible and that any condensate overflowing from the outlet cannot cause either a hazard to persons or damage to surrounding property or equipment.

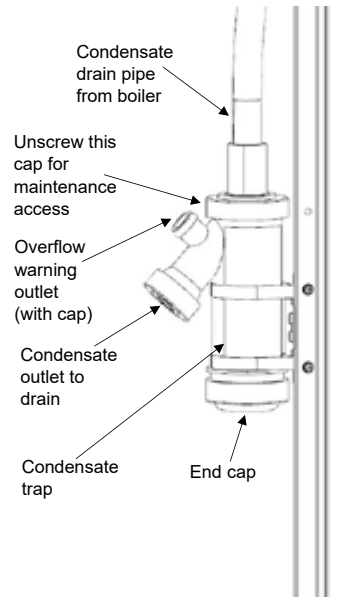

Figure 6-3: Condensate trap details

6.7 CONDENSATE DISPOSAL PIPEWORK

The condensate trap outlet is at an angle of 48° below the horizontal. This is to automatically give a 3° fall on any 'horizontal' runs of condensate disposal pipe. Refer to Figure 6-3 and see trap outlet/pipe.

The outlet of the trap will accept 21.5 mm to 23 mm OD Polypropylene overflow pipe for the condensate discharge pipe.

Possible routes for disposal pipework:

The boiler enclosure has one rectangular opening in each side and rectangular openings in the base. Refer to Section 2.4 for dimensioned drawings of the enclosure. These are designed to allow pipework to pass through, to suit the installation. These openings can be used to allow the condensate disposal pipe to exit the casing in one of the following ways:

Side outlet - The opening on either side of the enclosure can allow the condensate disposal pipe to be installed as follows:

- Connection to an internal stack - passing back through the wall of the house.
- Connection to an external soil stack adjacent to the boiler.
- Discharge into an adjacent (external) drain or gully.
- Discharge into a soakaway - with the pipe either above or below ground level.

Bottom Outlet - There are two openings in the base that can allow the condensate disposal pipework to be installed as follows:

- Discharge into a drain or gully beneath the boiler (e.g. a drain built into the concrete base for the boiler).
- Discharge into a soakaway - with pipe below ground level.

! NOTE !

When connecting plastic discharge pipe, ensure that the pipe is fully pushed into the outlet end on the flexible hose to prevent the possibility of leakage.

6.8 INSPECTION AND CLEANING OF TRAP

The trap **must** be checked at regular intervals (e.g. on every annual service) and cleaned as necessary to ensure that it is clear and able to operate.

The bottom bowl can be unscrewed from the trap body for inspection and cleaning.

To inspect and clean the trap:

1. Disconnect flexible condensate hose from inlet connector.
2. Unscrew the inlet connection nut.
3. Remove the inlet connector and nut from trap.
4. Disconnect the condensate disposal pipe from the trap outlet.
5. Remove trap from bracket.
6. Remove float from trap – clean if necessary.
7. Inspect inside of trap and clean as necessary.
8. Check the condition of the flexible condensate hose between the trap and the boiler.
9. Re-assemble trap, re-fit to boiler and re-connect flexible hose. Ensure that hose is fully pushed onto the trap inlet connector.

! CAUTION !

Failure to regularly check and clean the condensate trap may result in damage to the boiler and will not be covered by the product guarantee.

7 SEALED SYSTEMS

7.1 SEALED SYSTEM REQUIREMENTS

All Grant Vortex Pro Combi boilers must be used as part of a sealed system complying with the requirements of BS EN 12828, BS EN 12831 and BS EN 14336.

The maximum temperature of the central heating water is 75°C.

The boiler is supplied factory fitted with the following items:

- 24 litre diaphragm expansion vessel complying with BS EN 13831
- Pressure gauge
- Pressure relief (safety) valve
- Approved filling loop

7.1.1 EXPANSION VESSEL

On all models the expansion vessel is factory fitted on the front of the boiler, inside the casing.

It is connected to the boiler via a flexible hose to allow the vessel to be removed from the boiler to access the front cleaning door without disconnecting it. Take care to ensure that the flexible hose is not twisted or kinked.

Refer to Section 4.9 for further installation details.

! NOTE !

Ensure that the expansion vessel is of sufficient size for the system volume.

Refer to BS 7074-1 or the Domestic Heating Design Guide to check the vessel size required.

7.1.2 PRESSURE GAUGE

The pressure gauge is factory fitted in the boiler control panel. It has an operating range of 0 to 4 bar. Refer to Section 1.4.

7.1.3 PRESSURE RELIEF (SAFETY) VALVE

The pressure relief (safety) valve is factory fitted to the flow pipework on the top of the boiler.

A discharge pipe should be connected to the outlet of the pressure relief (safety) valve. This discharge pipe must terminate in a position that will allow the discharge to be seen, but cannot cause injury to persons or damage to property. Refer to Figure 5-1 for the position of the PRV on all models.

7.1.4 FILLING LOOP

In order to fill or top up the heating system, a factory fitted filling loop is located at the front of the boiler, to the right of the expansion vessel.

Refer to Section 7.2 for details on how to fill and vent the system.

7.1.5 HEATING SYSTEM

The maximum 'setpoint' temperature for the central heating water is 75°C. Refer to Section 1.1.

An air vent should be fitted in the flow and return pipes of the highest point of the system.

If thermostatic radiator valves are fitted to all radiators, a system by-pass must be fitted. The by-pass must be an automatic type.

All fittings used in the system must be able to withstand pressures up to 3 bar. Radiator valves must comply with the requirements of BS 2767.

One or more drain taps (to BS 2879) must be used to allow the system to be completely drained.

If thermostatic radiator valves are fitted, the system must incorporate an adequate by-pass.

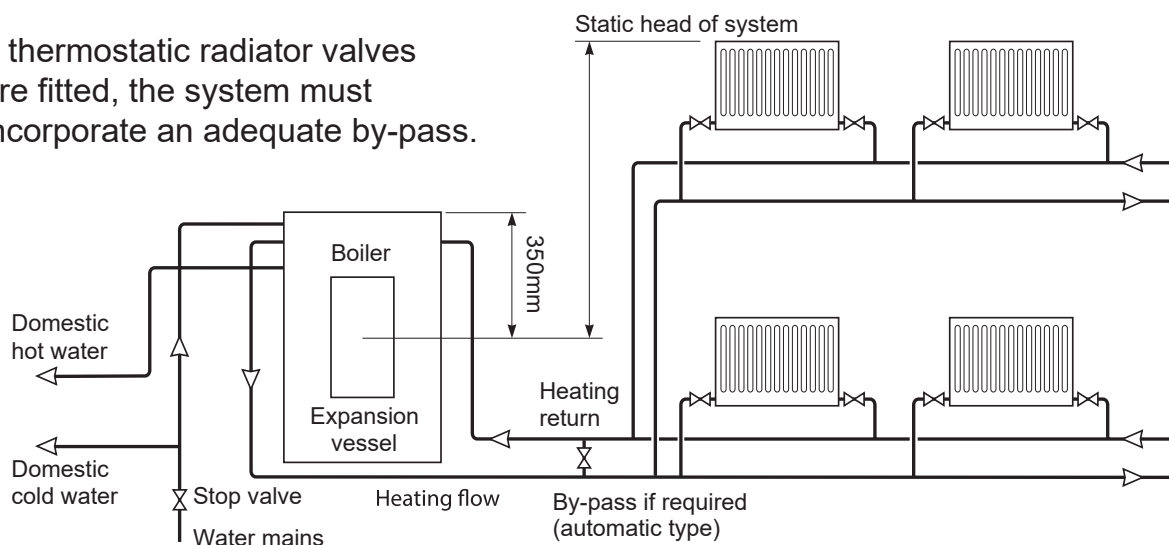

Figure 7-1: Sealed system

7.2 FILLING THE SEALED SYSTEM

Filling of the system must be carried out in a manner approved by the local Water Undertaking.

! WARNING !

Only ever fill or add water to the system when it is cold and the boiler is off. Do not overfill.

The procedure for filling the sealed system is as follows:

1. Check the air charge pressure in the expansion vessel BEFORE filling the system.

! NOTE !

The air charge pressure can only be correctly checked when the system water pressure is zero.

The expansion vessel air charge pressure should always be slightly greater than the maximum static head of the system, in bar, at the level of the vessel (1 bar = 10.2 metres of water).

For example: If the height to the top of the highest radiator from the centre of the expansion vessel is 5metres, then the static head at the vessel would be 0.5 bar. Refer to Figure 7-1.

The air charge pressure must not be less than the actual static head at the point of connection.

! NOTE !

The air charge pressure may be checked using a tyre pressure gauge on the expansion vessel Schraeder valve.

The vessel may be re-pressurised, when necessary, using a suitable pump. When checking the air charge pressure, the water in the heating system must be cold and the system pressure reduced to zero.

2. Check all air vents are fully open. Refer to Figure 5-1.
3. Ensure that the flexible filling loop is connected between the double check valve (on the cold water pipe) and the filling point on the drain cock connection in the lower right corner of the boiler.
Also ensure that the shut off valves on both the double check valve and the fill point are closed.
Note that these valves are open when the operating lever is in line with the valve, and closed when it is at right angles to it.
4. Open the shut off valve on the fill point valve.
5. Gradually open the shut off valve on the double check valve until water is heard to flow into the system from the cold water supply.
6. When the needle of the pressure gauge is between 0.5 and 1.0 bar, close the shut off valve on the double check valve.
7. Vent each radiator in turn, starting with the lowest one in the system, to remove air.
8. Continue to fill the system until the pressure gauge indicates between 0.5 and 1.0 bar. Close the fill point valve.
The system fill pressure (cold) should be 0.2 - 0.3 bar greater than the vessel air charge pressure.
Refer to the Domestic Heating Design Guide for further information if required.
9. Repeat steps 5 to 7 as required until system is full of water at the correct pressure and vented.
10. Water may be released from the system by manually operating the safety valve until the system design pressure is obtained.
11. Close the shut off valves on the fill point and double check valves and disconnect the filling loop.
12. Check the system for water soundness, rectifying where necessary.

7.3 VENTING THE PUMP

For those heating circulating pumps fitted with a vent plug, it is important that the pump is properly vented to avoid an air lock and also prevent it running dry and damaging the bearings.

Unscrew and remove the plug from the centre of the pump motor. Using a suitable screwdriver, rotate the pump spindle about one turn. Replace the plug in the motor. Do not over tighten.

! NOTE !

Some heating circulating pumps are not fitted with a vent plug so it is not possible to vent these pumps in the manner described above. Refer to pump manufacturers own instructions for further details.

If a Wilo Para pump is used, please refer to Appendix A2 at the back of this installation and servicing manual for guidance on venting the pump.

7.4 PRESSURE RELIEF (SAFETY) VALVE OPERATION

Check the operation of the pressure relief (safety) valve as follows:

1. Turning the head of the valve anticlockwise until it clicks. The click is the safety valve head lifting off its seat allowing water to escape from the system.
2. Check that the water is escaping from the system.
3. Top-up the system pressure, as necessary.

! NOTE !

For information on the circulating pump fitted to all Vortex Pro combi models, please refer to Appendix A1 or A2 as required at the back of this installation and servicing manual.

8 ELECTRICAL

! WARNING !

Ensure that the electrical supply has been isolated before making any connections to the boiler.

8.1 GENERAL

The Vortex Pro Outdoor Combi requires a permanent ~230 V 1ph 50Hz supply. It must be protected by a 5 Amp fuse.

Refer to Figure 8-1 for the control panel wiring diagram for all Vortex Pro Outdoor combi models.

Refer to Figures 8-2 and 8-3 for wiring diagrams showing how to connect the control system.

! WARNING !

The Vortex Boiler contains electrical switching equipment and must be earthed.

The supply must be fused at 5 Amp and there must only be one common isolator for the boiler and control system, providing complete electrical isolation.

A fused double pole switch or a fused three pin plug and shuttered outlet socket should be used for the connection.

The power supply cable should be at least 0.75 mm² PVC as specified in BS 6500, Table 16.

All the wiring and supplementary earth bonding external to the boiler must be in accordance with the current IET Wiring Regulations.

Any room thermostat or frost thermostat used must be suitable for use on mains voltage.

In the event of an electrical fault after installation of the boiler, the following electrical system checks must be carried out:

- Short circuit
- Polarity
- Earth continuity
- Resistance to earth

! NOTE !

If the supply cord is damaged, it must be replaced by the manufacturer, its service agent or similarly qualified persons in order to avoid a hazard.

8.2 CONNECTING THE POWER SUPPLY

The Vortex Pro External Combi is supplied fitted with an electrical isolation plug, located in the left hand end of the boiler control panel. All electrical wiring to the boiler must be made to this plug.

! NOTE !

Ensure that the route and length of the supply cable is such that the boiler front cover plate can be easily removed without disconnecting the supply cable from the terminal block.

The isolation plug is connected to the power supply and heating / hot water controls as follows:

1. The isolation plug is located on the control panel. Pull the plug to the left to remove it from the socket in the left hand end of control panel.
2. Remove the two screws and prise off the cover from the plug to gain access to the five terminals.

! NOTE !

Pass the cable from the electrical power supply and heating / hot water controls through the cable clamp on the underside of the control panel before making connections to the isolating plug.

3. Connect the electrical supply and heating / hot water controls to the terminals in the isolating plug as follows:
 - Terminal L1 - Heating on (from Timer, Thermostat or Programmer).
 - Terminal L2 - Hot water on (from Programmer).
 - Earth Terminal - Green / Yellow to mains Earth.
 - Terminal N - Blue to mains Neutral.
 - Terminal L3 - Brown to mains Live (including permanent live for Frost Thermostat).

The terminal numbers are marked on the top cover of the plug. Refer to Sections 8.2 and 8.3 for details of controls wiring BEFORE making connections to the isolating plug.

4. Make the remaining required connections to the control panel, as detailed in this section.
5. Replace the cover on the plug, refit the two screws and ensure it is securely fitted. Measure a maximum of 350mm of cable between the plug and the cable clamp below the control panel and tighten the cable clamp to secure the cable.

! WARNING !

Check that the cable is securely clamped and that the cable length between the clamp and the plug is no more than 350mm.

! WARNING !

After completing electrical connections and before reconnecting the electrical supply to the boiler, replace the wiring cover on the plug and secure it using the screws provided.

6. Re-fit the isolation plug into the socket in the control panel.
7. Replace the top casing panel and four retaining screws following the procedure outlined in Section 4.7 and replace the casing door.
8. Re-connect the electrical supply and check operation of heating system controls (programmer, room thermostats, etc.).
9. Refer to Instructions provided with the programmer for operation and setting.
10. Leave the Programmer and Thermostat Instructions with the user after installation for their future reference.

BURNER LEAD PLUG/SOCKET CONNECTOR

On all models, the electrical cable between the boiler control panel and burner is now fitted with an in-line 3-way plug and socket connector. This enables the burner to be easily disconnected from the boiler control panel for ease of removal for servicing.

! NOTE !

A Service switch is fitted to the control panel to allow the Service Engineer to test-fire the boiler.

When set to 'ON' the switch temporarily by-passes the external control system to operate the boiler.

This is a 'momentary' or non-latching switch that cannot be left set to ON. The boiler will automatically revert to normal operation when 15 minutes have elapsed since it was last operated.

If required, this 15 minute override period can be stopped by switching the boiler On / Off switch OFF and then back to ON.

The boiler will then operate as normal under control of the external heating/hot water controls (timer, room thermostat or programmer).

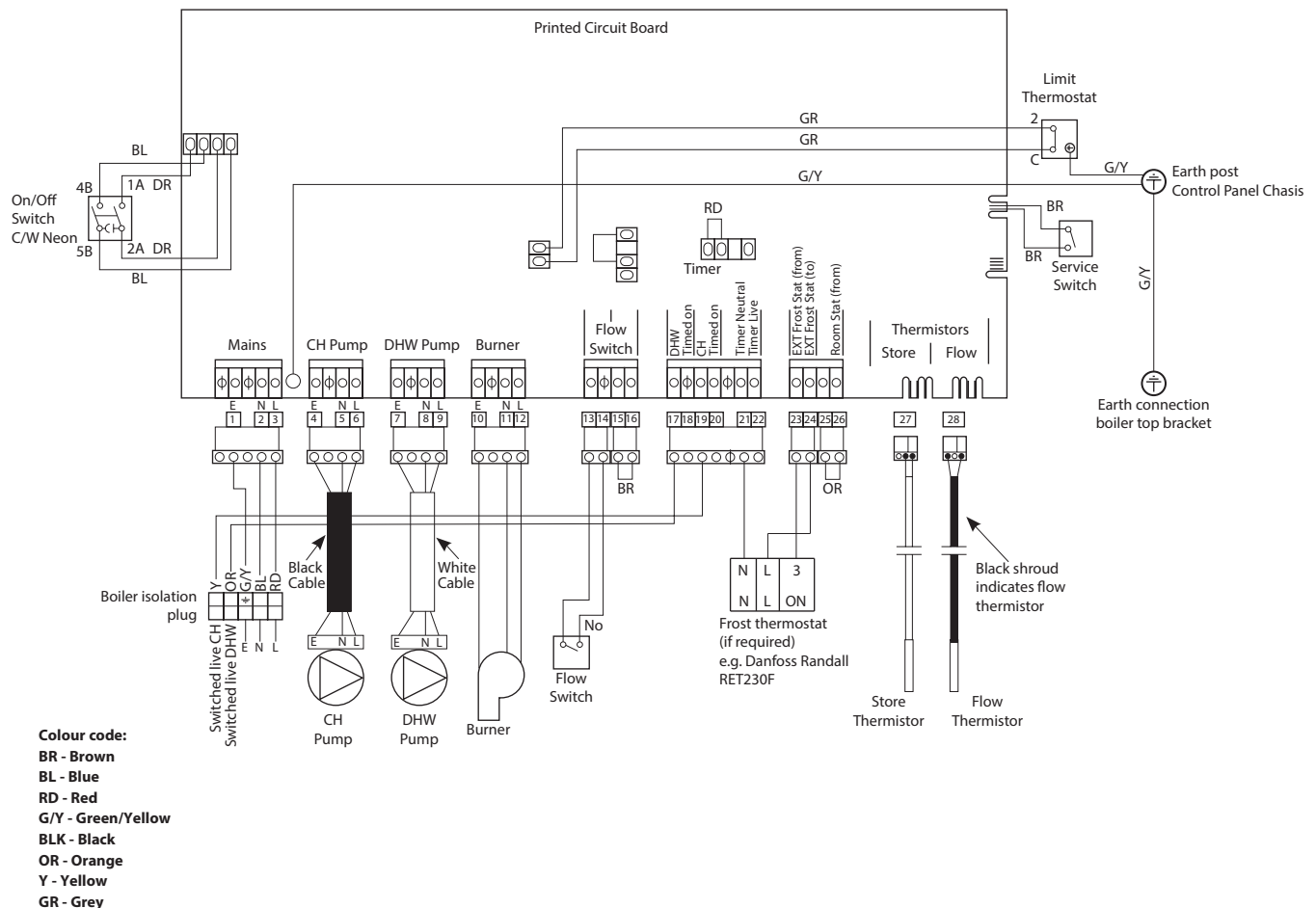

Figure 8-1: Boiler Wiring Diagram

8.3 CONNECTING THE CONTROLS - HEATING ONLY

To control the central heating on / off periods only (and NOT the domestic hot water), it is recommended to use a single channel timer and room thermostat.

These should be sited at a suitable and convenient location within the property.

The switched live from these central heating controls must be connected to Terminal L1 on the boiler electrical isolation plug. Refer to Figure 8-2 for connection details.

When using the boiler in this way, i.e. controlling the heating operation of the boiler only, a link must be fitted between terminals L2 and L3 in the isolation plug. This will enable the boiler to operate to supply hot water on demand at all times.

CONNECTION OF AN EXTERNAL REMOTE TIMER AND ROOM THERMOSTAT

! WARNING !

Any remote timer must be of a single channel 230V type with voltage free output contacts. Refer to Figure 8-2 for connection details.

Connect the switched live output from the programmer/room thermostat to terminal L1 of the boiler isolation plug. Fit a link between terminals L2 and L3 in the isolation plug. Refer to Figure 8-2.

Connect the mains supply to the boiler isolation plug as follows (refer to Figure 8-2):

- Permanent live to terminal L3.
- Neutral to terminal N.
- Earth to earth terminal.

Re-connect the electrical supply and check the operation of the timer and room thermostat.

Refer to the Fitting & User instructions provided for with the timer for operating and setting.

Leave the Timer and Thermostat Fitting & User instructions with the user after installation.

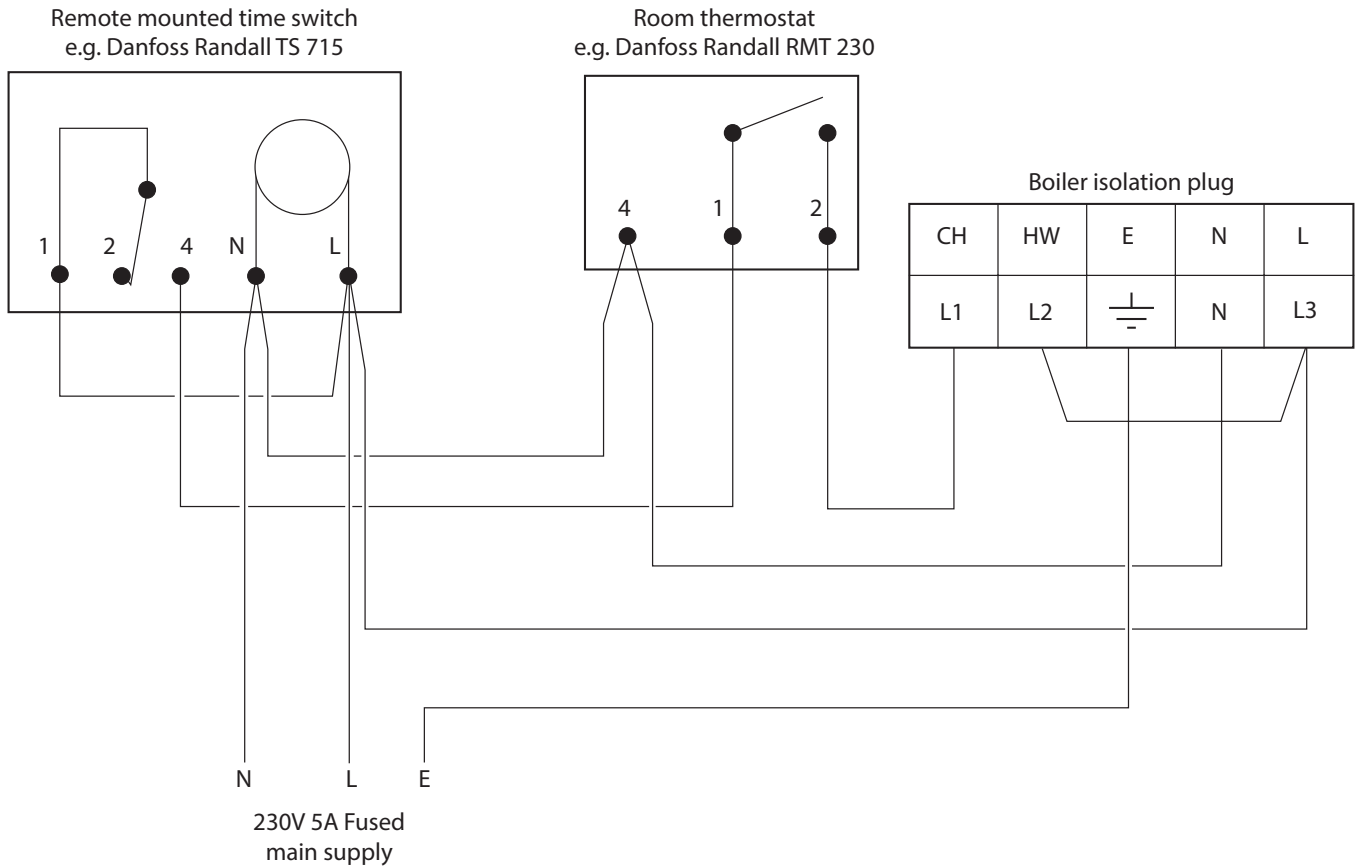

Figure 8-2: Connections for remote timer and room thermostat

8.4 CONNECTING THE CONTROLS - HEATING AND HOT WATER

If control of both the heating and hot water operation of the boiler is required, it is recommended to use a two channel programmer and room thermostat.

! NOTE !

If a two-channel programmer is used with the Vortex Outdoor Combi, the user must be made aware that if the hot water channel is left in the OFF position, hot water may not be available on demand, and that the primary store may need to recover before any hot water is available.

! NOTE !

The remote two-channel programmer must be suitable for 230V and internally linked. Refer to Figure 8-3 for connection details.

CONNECTION OF EXTERNAL REMOTE PROGRAMMER

Connect the switched live output from the Hot Water channel out of the programmer (DHW ON terminal) to terminal L2 of the boiler isolation plug. Refer to Figure 8-3.

Connect the SWITCHED live output from the Heating channel of the programmer (CH ON terminal) to terminal L1 of the boiler isolation plug, via the room thermostat. Refer to Figure 8-3.

Connect the mains supply to the boiler isolation plug as follows (Refer to Figure 8-3)

- Permanent live to terminal L3
- Neutral to terminal N
- Earth to earth terminal

Re-connect the electrical supply and check the operation of the programmer and room thermostat.

Refer to the Fitting and User instructions provided with the programmer for operating and setting information.

Leave the Programmer and Thermostat Fitting and User instructions with the user after installation.

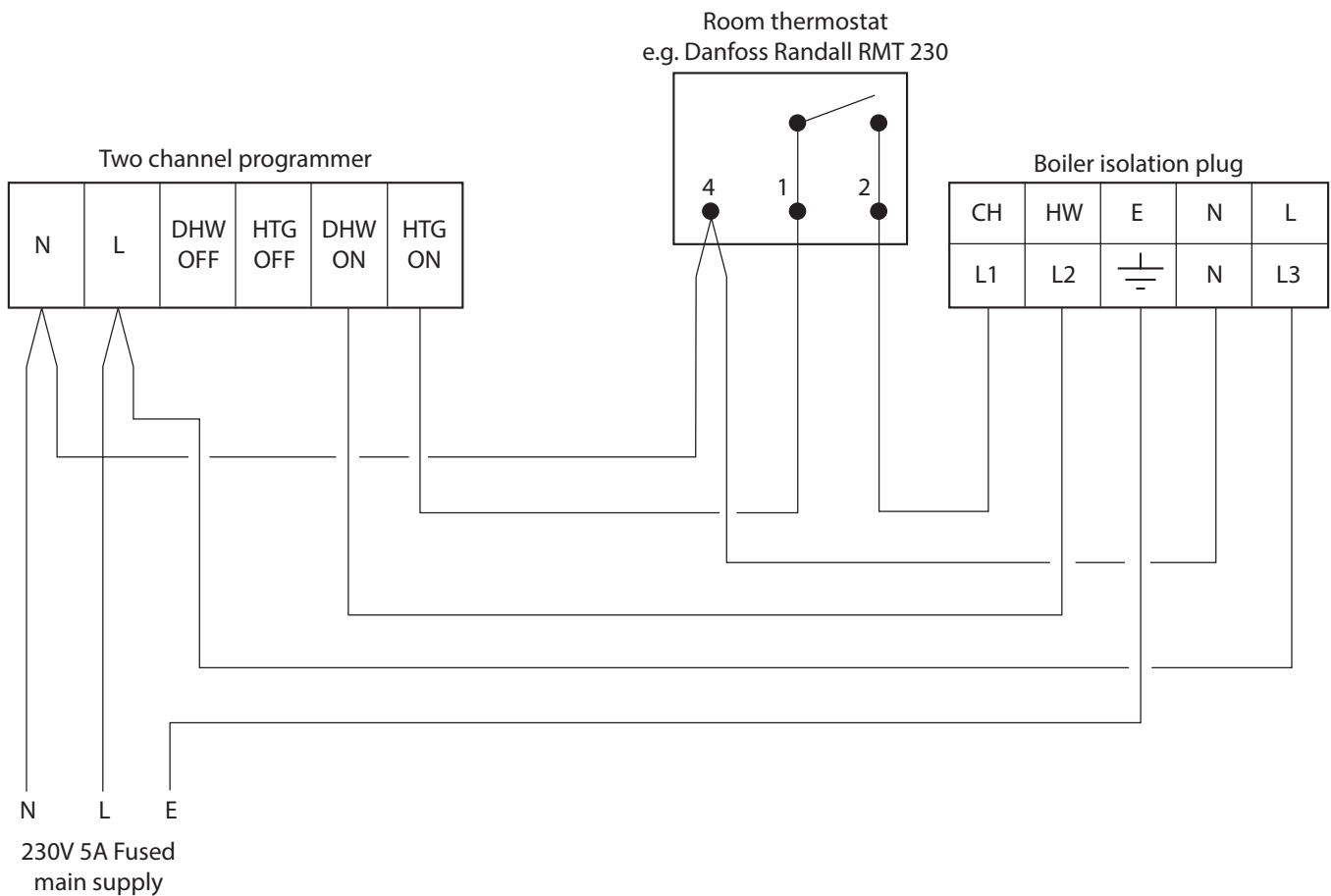

Figure 8-3: Connections for remote two channel programmer and room thermostat

8.5 CONNECTING A REMOTE FROST THERMOSTAT

The boiler is fitted with two forms of pre-set internal frost protection, as follows:

Water temperature:

Should the central heating water temperature (detected by the flow thermistor) fall to below 8°C this frost protection function will be activated and will operate as follows to protect the boiler from freezing:

- The heating circulating pump will run for a period of 15 minutes. If during this time the water temperature exceeds 15°C the pump will stop.
- If after the 15 minutes the temperature is less than 10°C the burner will fire and continue to do so until the flow thermistor detects a temperature of 30°C when the burner will stop. The heating circulating pump will then run for a period of 2 minutes before also stopping.

Air temperature:

Should the air temperature around the boiler fall to below 5°C this frost protection will be activated and will operate as follows to protect the boiler from freezing:

- First the heating circulation pump will operate for a period of 15 minutes. If after that time the air temperature sensed exceeds 10°C the pump will stop.
- If after the 15 minutes the temperature is less than 10°C the burner will fire and continue to do so until the flow thermistor detects a temperature of 30°C when the burner will stop. The heating circulating pump will then run for a period of 2 minutes before also stopping.

For additional protection of either the entire heating system, or any exposed parts of the heating system (e.g. if the boiler is installed in an external boiler house, un-heated garage, attic or outdoors) a remote frost thermostat can be connected to the boiler. This will operate in conjunction with the internal frost protection and, when activated, the boiler will operate as described at the start of Section 8.5.

This remote frost thermostat should be sited within the house in such a place that any rise or fall in ambient air temperature can be detected, i.e. in a room with a radiator.

To connect a remote frost thermostat (for example, a Danfoss Randall RET230F), proceed as follows:

1. Remove the boiler door, top casing panel and insulation from boiler. (Refer to Section 4.7)
2. Remove the two screws at top of control panel (in cross member). Hinge down control panel front.
3. From rear of control panel, carefully feed the cable from the Frost thermostat through the upper grommet at the right hand end of the rear of the control panel.
4. Slacken the upper cable clamp on the inside rear face of the control panel. Feed the cable through the cable clamp.
5. Connect wires to terminals on control panel as follows:
 - Frost thermostat Neutral (N) to terminal 21 on PCB connector.
 - Frost thermostat Live (L) to terminal 24 on PCB connector.
 - Frost thermostat Switched Live-ON (3) to terminal 23 on PCB connector.
6. Refer to Figure 8-1 for typical connection of Remote Frost Thermostat.
7. If an alternative Frost thermostat to the Danfoss Randall RET230F is used, connect it in accordance with the frost thermostat manufacturer's instructions.
8. Make the remaining required connections to the control panel, as detailed in this section.
9. Secure the cable clamp.
10. Re-fit control panel front and secure using the two screws.
11. Replace boiler insulation, top panel and front casing door.

! NOTE !

This external frost thermostat will operate in parallel with the internal frost thermostat.

! NOTE !

For total system protection against freezing, particularly during extended periods without electrical power, Grant recommend the use of a combined heating system antifreeze and corrosion inhibitor, used in accordance with the manufacturer's instructions.

9 FLUE SYSTEM AND AIR SUPPLY

The boiler is supplied with a flue terminal. Refer to Section 4.7 for fitting details.

As an alternative to the terminal supplied, there are three external flue systems that can be used with the Vortex Pro Outdoor Combi boiler, all available from Grant UK.

PLUME DIVERTER KIT

This vertical system is available to purchase from Grant UK and is intended to be retrofitted to the flue terminal supplied with the boiler, in order to terminate the flue in a more preferable or permissible location.

GRANT GREEN SYSTEM

VERTICAL:

This vertical twin wall stainless steel insulated system replaces the low level terminal supplied with the boiler, and may terminate at high level or vertically as required.

HORIZONTAL:

This option allows the extension of the flue system in the horizontal plane in order to terminate the flue in a more preferable or permissible location.

These two systems are described in this section.

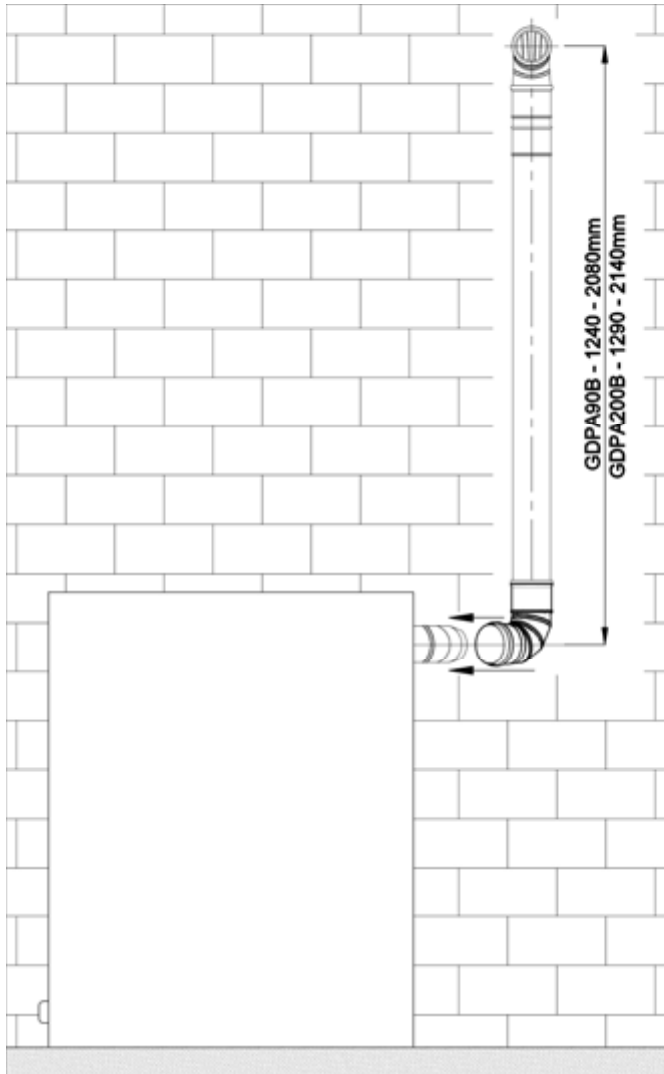

Figure 9-1: Plume diverter kit - Front View

! NOTE !

Ensure that the Plume Diverter Kit starter elbow is fully pushed onto the external boiler flue terminal. See above.

9.1 AIR SUPPLY

A sufficient permanent air supply to the boiler should be provided for the following reasons:

- For proper combustion of fuel and effective discharge of combustion products to the open air.
- For the ventilation of any confined space in which the boiler is installed to prevent overheating of the boiler and any equipment in and near the boiler.

Grant external boilers draw their air supply via the ventilation holes in recessed top edge of the front door of the boiler casing. These ventilation holes must not be obstructed.

Further details may be obtained from BS 5410-1.

9.2 PLUME DIVERTER KIT

Should the low level flue supplied with the boiler be discovered to cause a plume nuisance after its installation, a plume diverter kit is available to purchase from Grant UK for the purpose of re-directing the flue gases to a higher level (according to the minimum clearances shown in Figure 9-5).

The plume diverter kit has been designed to be retrofitted to the low level flue supplied with the external boiler by attaching the 90° elbow supplied with the kit directly to the boiler flue terminal.

This kit is available in two sizes, product codes as follows:

- GDPA90B - suitable for installations of up to 26kW (maximum vertical length of 2.08m)
- GDPA200B - suitable for installations ranging from 26-70kW. (maximum vertical length of 2.14m)

While every effort has been made to make this retrofit as simple as possible for the installer, it is necessary for the installer to drill an 8mm hole in the side of the existing flue terminal to ensure that the condensate produced by the flue gases during normal operation drain back into the boiler.

It is also necessary for the installer to spot drill two 3mm holes in the existing flue terminal. With the plume diverter starter elbow in its final position on the existing flue terminal, use the holes in either side of this elbow as a guide to drill the two holes in the terminal and fix the elbow to the existing terminal by driving one of the two self-tapping screws provided into each hole.

More detailed installation details for this system can be found in the fitting instructions supplied with the kit.

Please see Figures 9-1 and 9-2 for a visual representation of the plume diverter kit fitted onto a Grant Vortex Pro Outdoor Combi boiler and Table 9-1 for the distance of the plume diverter centre line from an external wall when correctly fitted to the boiler (Dimension A in Figure 9-2).

A series of extensions and other accessories are available for use with this kit. Please contact Grant UK for further information.

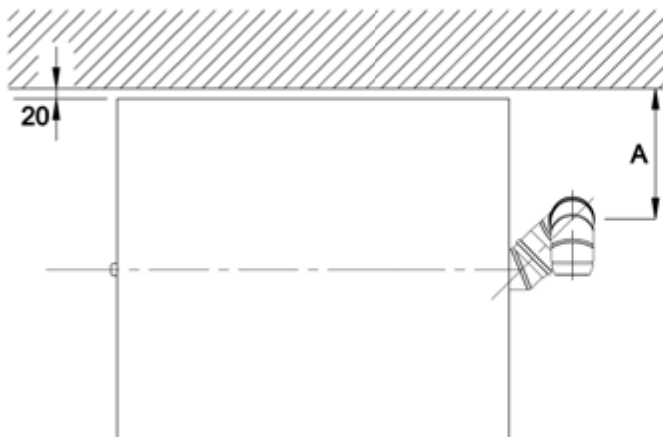

Figure 9-2: Plume diverter kit - Plan View

Table 9-1: Distance of plume diverter centre from external wall

Model	Dimension A (mm)
21	251
26	251
36	224

9.3 CONVENTIONAL FLUE SYSTEMS

! NOTE !

Under no circumstances can Grant Vortex boilers be installed with existing flue systems. Only flue systems and components suitable for wet flues should be used. Failure to install the correct type of flue system will invalidate the guarantee.

Grant condensing boilers have high operating efficiencies and low flue gas temperatures. Care must be taken to ensure the flue system is suitable for the very low flue gas temperatures and condensate in the flue gases.

Suitable conventional flue systems are available from Grant UK.

The flue must terminate in a down draught free area, i.e. at least 600 mm above the point of exit through the roof or preferably above the ridge level.

The condensate may be allowed to run back into the boiler. A condensate drain at the base of the flue system is not required.

The high level flue terminal must be at least 600 mm from any opening into the building, and 600 mm above any vertical structure or wall less than a horizontal distance of 750 mm from the terminal.

More detailed information on the siting of the flue terminal can be found in Figure 9-5 and Table 9-3.

The internal flue diameter for all models must be 100 mm (4 in).

Twin wall flues are recommended for externally run flues to reduce the possibility of the condensate freezing in the flue.

No part of any flue system should be made of an asbestos material; aluminium must not be used in any part of the flue. Only stainless steel flue components should be used.

If the draught conditions are satisfactory, the flue should terminate with a standard cowl.

Refer to the locally applicable Building Regulations, BS 5410-1 and OFTEC Installation Requirements (OFTEC Books 2 and 3) for further guidance on conventional flue systems.

! CAUTION !

It is important to ensure that the flue system is sealed and that condensate cannot escape. Up to 1.5 l/h of condensate can be produced in a conventional flue system.

Do not use fire cement. The use of high temperature silicone sealants is recommended.

! NOTE !

To comply with the requirements of the Building Regulations Approved Document J - conventional flue systems must have a flue data plate.

9.4 EXTERNAL VERTICAL CONVENTIONAL FLUE (GREEN SYSTEM)

The external system can terminate at either high level or vertically (above roof level) as required. The vertical or high level terminal must terminate in accordance with BS 5410-1. The minimum dimensions for locating the high level terminal from building features (windows, doors, etc.) are shown in Figure 9-5.

The Green system comprises of five insulated extension lengths, 45° elbows, a vertical terminal and a high level horizontal terminal.

Locking bands are provided with all vertical extensions and terminals. Ensure that the locking bands are fitted.

Two types of wall bracket are also available (standard and adjustable) to support the vertical flue components.

The maximum vertical height (from the top of the boiler to the terminal) for the 'Green' system twin wall flue is 19 metres. Only two 45° elbows may be used in the complete system.

If the flue terminal is fitted less than 2 metres above a surface to which people have access, the terminal must be protected by a guard. The guard must be manufactured from stainless steel and should be fitted centrally over the flue terminal and securely fixed to the wall.

CONNECTION OF GREEN FLUE SYSTEM

1. Connect Grant Green system to the boiler flue outlet using the Grant Green system External Module starter elbow (product code: GKM90 for models up to 26kW or GKM200 for models ranging from 26-70kW).
2. Fit the starter elbow into the boiler connector after first ensuring that the seal is in place in the connector.

! NOTE !

Lubricate the seal on the boiler connector using the lubricant provided before attempting to fit the starter piece. Ensure that seals in all flue sections are lubricated before installing.

3. Assemble the remainder of the flue system as required, lubricating the seal on each component before fitting and securing every joint with the locking band provided.

The external vertical flue (Green system) components available from Grant UK can be found in Figure 9-3 and Table 9-2.

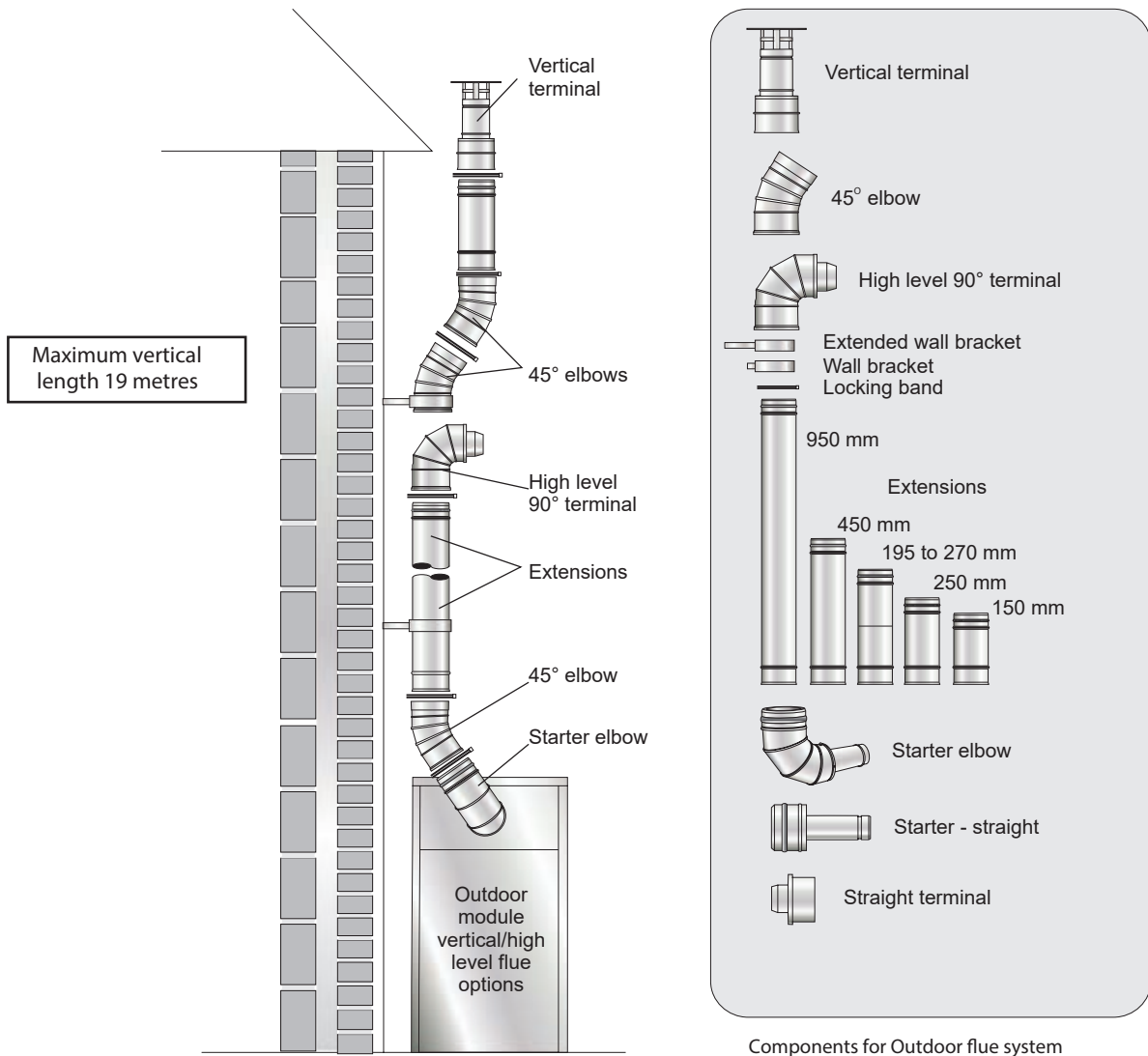

Figure 9-3: Vertical external conventional flue (Green system)

Green System Components			
Item - for models up to 26kW output	Part No.	Item - for models up to 36kW output	Part No.
External starter elbow	GKM90	External starter elbow	GKM200
External starter - straight	GKM90C	External starter - straight	GKM200C
150mm extension	GX150/90	150mm extension	GX150/200
250mm extension	GX250/90	250mm extension	GX250/200
450mm extension	GX450/90	450mm extension	GX450/200
950mm extension	GX950/90	950mm extension	GX950/200
195-270mm adjustable extension	GXA250/90	195-270mm adjustable extension	GXA250/200
45 elbow	GE45/90	45 elbow	GE45/200
High level terminal	GTH90	High level terminal	GTH200
Vertical terminal	GTV90	Vertical terminal	GTV200
Wall bracket - standard	GWB90	Wall bracket - standard	GWB200
Wall bracket - extended	GEB90	Wall bracket - extended	GEB200
Straight terminal - horizontal flue	GTL90	Straight terminal - horizontal flue	GTL200

Table 9-2: Green system components - product codes

9.5 EXTERNAL HORIZONTAL CONVENTIONAL FLUE (GREEN SYSTEM)

This option uses the Grant Green system External Module straight starter section (GKM90C for models up to 26kW or GKM200C for models ranging from 26-70kW), replacing the low level terminal and flue guard supplied with the boiler, along with components from the Grant Green system. See Figure 9-4.

It is possible to extend the flue horizontally by a maximum of 3 metres in total flue length by using the green system. A maximum of two 45° elbows may be utilised when extending the flue using this system.

For further information on the connection of the Green system, please refer to Section 9.4.

! NOTE !

The flue system from the external module can be extended either vertically OR horizontally by using the Green System.

NOT a combination of both.

A complete list of Grant Green system flue components can be found in Figure 9-3 and Table 9-2.

Information on the siting of the flue terminal can be found in Section 9.6.

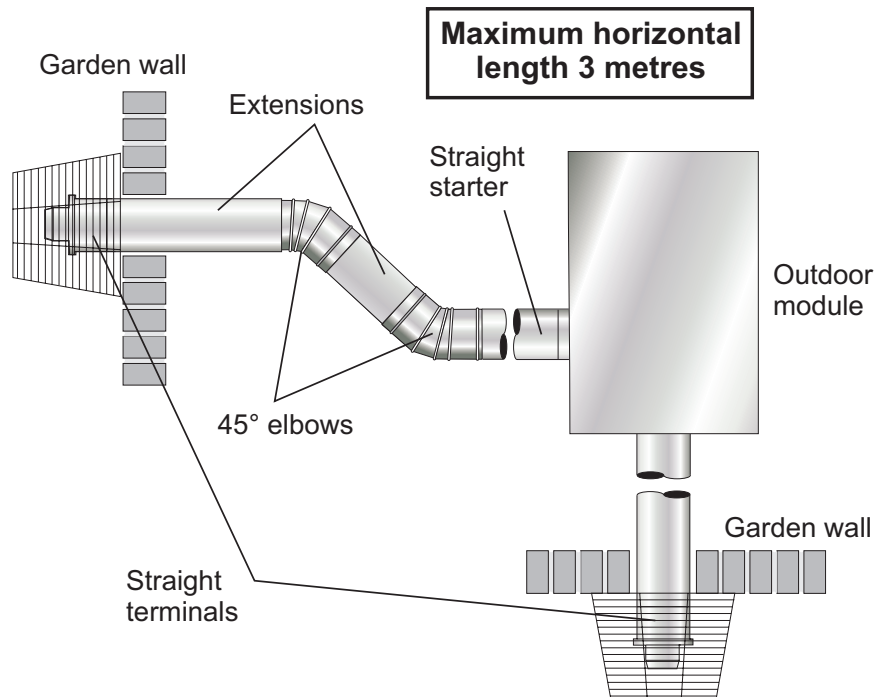

Figure 9-4: Horizontal external flue

9.6 FLUE CLEARANCES

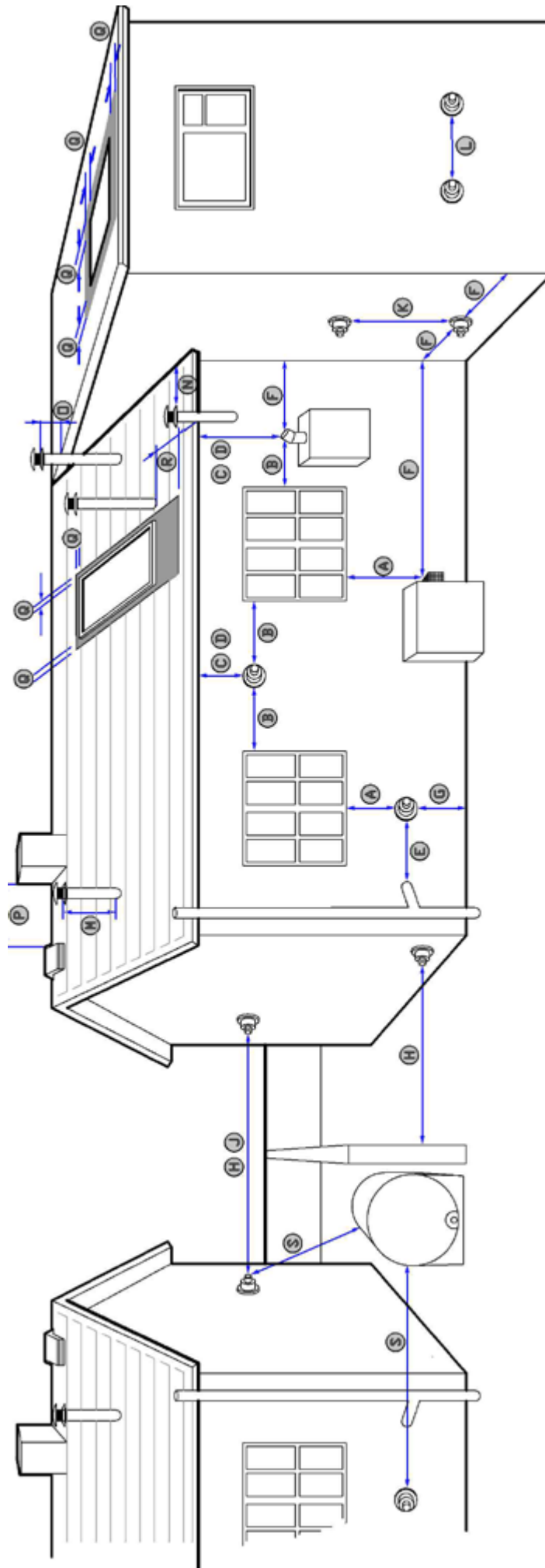

Figure 9-5: Flue clearances

Table 9-3: Flue clearances

Ref	Location of outlet	Minimum distance (mm)	
		Pressure jet	Condensing
A	Directly below an opening, air brick opening, opening window, etc.	600	1,000 **
B	Horizontally to an opening, air brick opening, opening window, etc.	600	1,000 **
C	Below a gutter, eaves or balcony with protection	75 *	1,000 **
D	Below a gutter, eaves or balcony without protection	600	1,000 **
E	From vertical sanitary pipework	300	
F	From an internal or external corner	300	
G	Above ground or balcony level	300	
H	From a surface or boundary facing the terminal	600	2,500 **
J	From a terminal facing the terminal	1,200	
K	Vertically from a terminal on the same wall	1,500	
L	Horizontally from a terminal on the same wall	750	
M	Above the highest point of an intersection with the roof	600	
N	From a vertical structure to the side of the terminal	750	
O	Above a vertical structure less than 750 mm from the side of the terminal	600	
P	From a ridge terminal to a vertical structure on the roof	1,500	
Q	Above or to the side of any opening on a flat or sloping roof	300	
R	Below any opening on a sloping roof	1,000	
S	From oil storage tank (Class 1)	1,800 ***	

* A heat shield at least 750 mm wide must be fitted to provide protection of combustible material.

** Clearances required by BS 5410-1:2019 to alleviate the effect of plume nuisance. If a risk assessment shows that there will be no impact from pluming, then the 'pressure jet' figure could apply - seek confirmation from Local Authority Building Control.

*** Seek guidance from OFTEC Book 3 (Oil Storage and Supply).

NOTES

- Appliances burning class D fuel have additional restrictions. Refer to BS 5410-1:2019.
- Vertical structure in N, O and P includes tank or lift rooms, parapets, dormers, etc.
- Terminating positions A to L are only permitted for appliances that have been approved for low level flue discharge when tested in accordance with BS EN 303-1, OFS A100 or OFS A101.
- Terminating positions should be at least 1.8 metres from an oil storage tank (Class 1) unless a wall with at least 30 minutes fire resistance and extending 300 mm higher and wider than the tank is provided between the tank and the terminating position.
- Where a flue is terminated less than 600 mm away from a projection above it and the projection consists of plastics or has a combustible or painted surface, then a heat shield of at least 750 mm wide should be fitted to protect these surfaces.
- If the lowest part of the terminal is less than 2 metres above the ground, balcony, flat roof or other place to which any person has access, the terminal should be protected by a guard.
- Notwithstanding the dimensions given above, a terminal should not be sited closer than 300 mm to combustible material. In the case of a thatched roof, double this separation distance should be provided. It is also advisable to treat the thatch with a fire retardant material and close wire in the immediate vicinity of the flue.
- A flue or chimney should not pass through the roof within the shaded area delineated by dimensions Q and R.
- Where protection is provided for plastics components, such as guttering, this should be to the standard specified by the manufacturer of the plastics components.
- Terminals must not be sited under car ports.
- Terminals at low levels (terminals under 2.1 metres) have more restrictive recommendations and should not be positioned near public footways, frequently used access routes, car parking spaces less than 2.5 metres from the terminal or patio's (hard surface area).

Further guidance can be obtained from BS 5410-1:2019, OFTEC Book 4 (Installation) and Approved Document J.

Grant UK flue products are fully compliant with the CE (Communauté Européenne/European Community) standards having undergone rigorous product testing.

10 COMMISSIONING

To ensure safe and efficient operation, it is essential that a Grant Vortex Pro Combi boiler is commissioned as detailed in the following procedure.

To access the controls, remove the front door from the boiler casing (pull forward at the bottom and then lift off).

The controls are shown in Figure 10-1 and other components are shown in Figure 10-2.

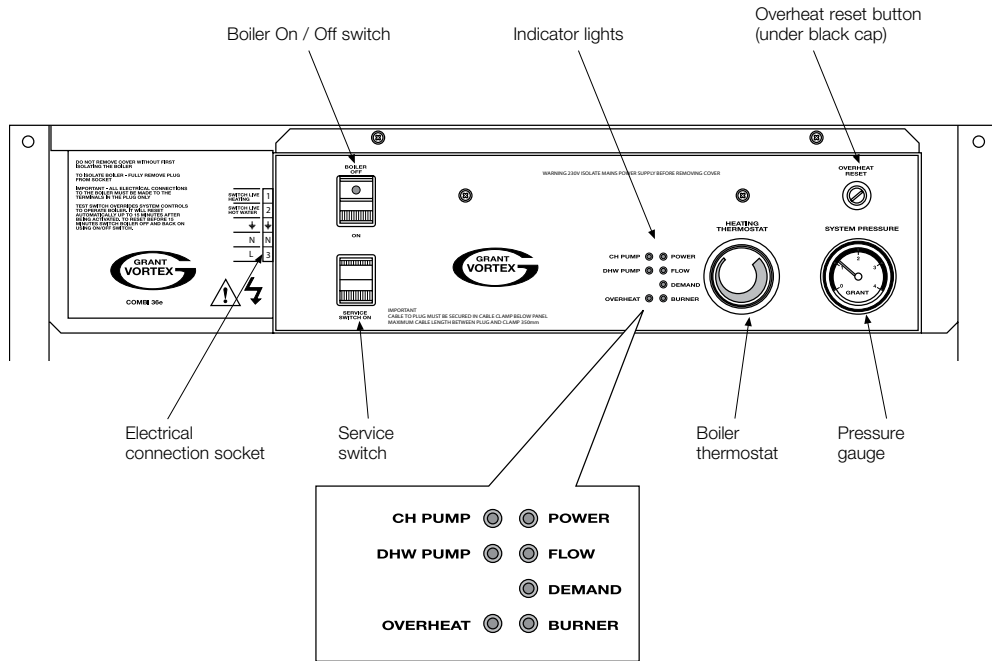

Figure 10-1: Vortex Pro External Combi boiler control panel

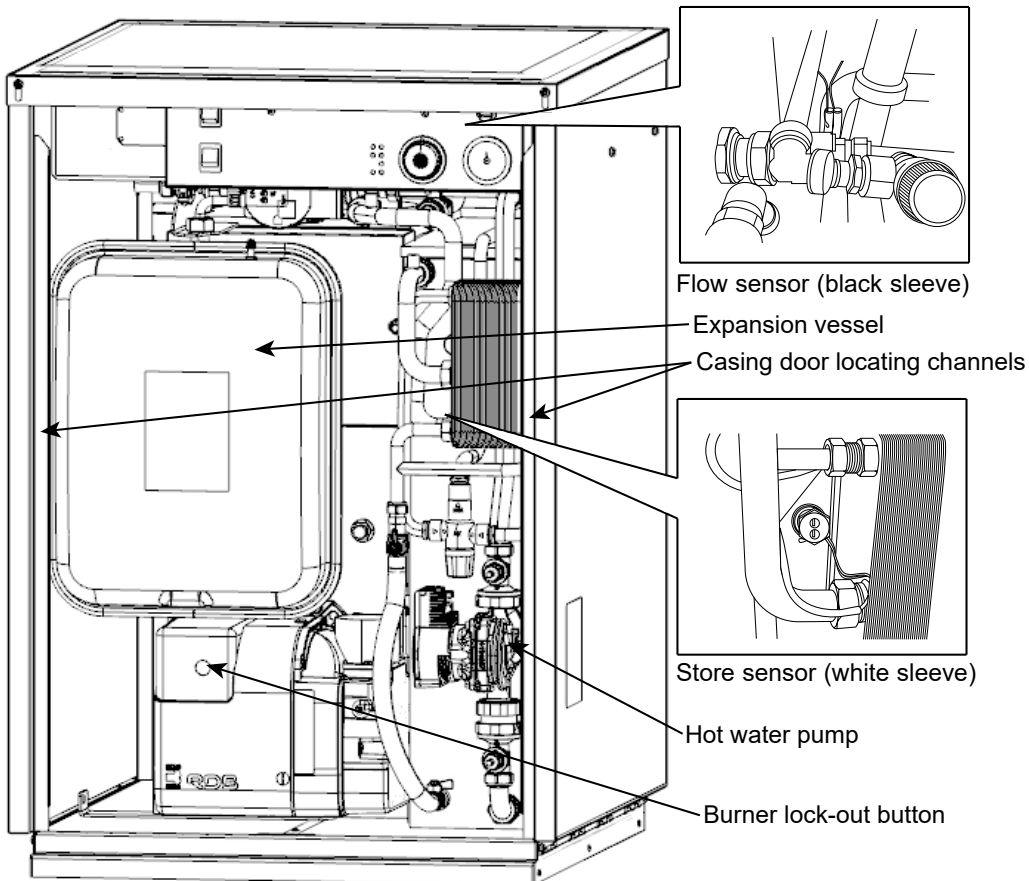

Figure 10-2: Position of boiler components - Vortex Pro Outdoor Combi

10.1 BEFORE SWITCHING ON

1. Ensure the boiler is isolated from the electrical supply and the boiler On/Off switch is set to OFF.
2. Remove the front casing door.
3. Remove the four screws retaining the top casing panel and remove the top casing panel, then check that the high limit thermostat bulb and boiler thermostat bulb are correctly located in their respective pockets. Refer to Figure 5-1. Ensure the store sensor is correctly located in its pocket. Refer to Figure 10-2. Check condition of all thermostat capillaries. Ensure they are not damaged, broken, kinked or crushed.
4. Remove the nuts and washers securing the front cleaning door. Withdraw the door – take care as it is HEAVY!
5. Check that the turbulators are in position and that the ends are vertical. Refer to Figure 11-4.
6. Check that the baffles are in position. Refer to Figures 11-1, 11-2 or 11-3 as required.
7. Re-fit cleaning door and check it is fitted correctly and that a good seal is made.
8. Unscrew the burner fixing nut (located at the top of the mounting flange) and remove the burner from the boiler.
9. Check/adjust the burner settings as described in Section 10.2 (Burner Settings).
10. Re-fit the burner to the boiler and tighten the fixing nut. DO NOT OVERTIGHTEN!
11. Check that the sealed system has been vented and pressurised and there are no leaks.
12. Ensure all air vents are open. Refer to figure 5-1.
13. Check that all fuel line valves are open.
14. Remove the plastic burner cover if it was not previously removed.
15. Connect a combined vent manifold and pressure gauge to the pressure gauge connection port on the oil pump. See Figure 3-5. Open the vent screw on the vent manifold to vent the oil supply whilst the pump is running.
16. Check that all system controls are calling for heat and turn the boiler thermostat to maximum.

10.2 BURNER SETTINGS: RDB2.2 BX BURNERS

With the burner removed from the boiler:

1. Unscrew and remove the two screws holding the air intake spigot to the top of the air inlet cover.
2. Remove and discard the air intake spigot and gasket.
3. Fit the slotted air intake (provided loose with the boiler) to the top of the air intake cover and secure using one of the two screws previously removed.
4. Remove the burner head. Refer to Figure 10-3. Loosen the three fixing screws (1) and remove head (2) from burner.

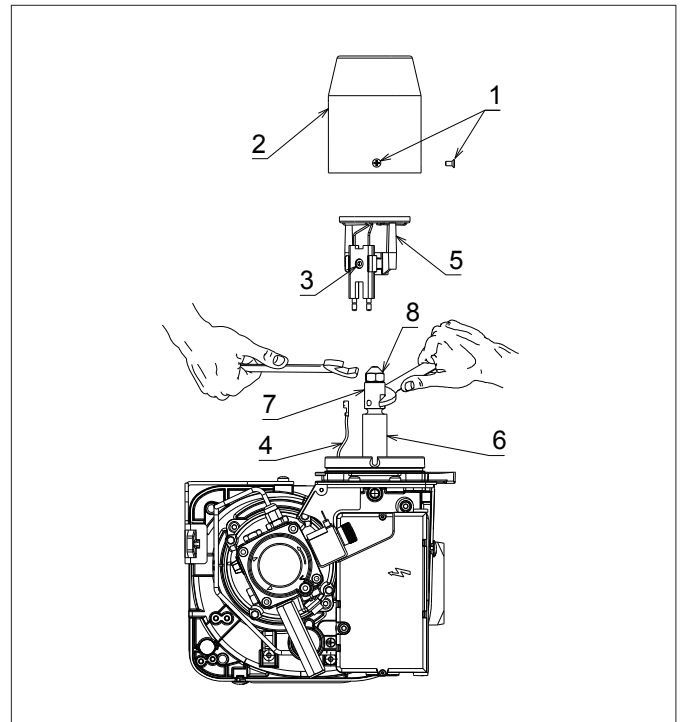

Figure 10-3: Burner head, diffuser and nozzle holder

5. Check the nozzle is correct for the required boiler output. Refer to Table 2-2 for the correct nozzle size and type for the required boiler output.
6. If the nozzle needs to be replaced - remove the diffuser/electrode assembly. Refer to Figure 10-3.
 - Using a 4 mm Allen key, loosen the diffuser fixing screw (3) on the electrode assembly.
 - Lift diffuser/electrode assembly (5) up and off the nozzle holder.
 - Disconnect both ignition leads (4) from the electrodes.
7. Use a 16 mm spanner to remove/re-fit the nozzle, whilst holding the nozzle holder using a 19 mm spanner.

! CAUTION !

The use of an ill-fitting spanner will damage the nozzle and could lead to an incorrect flame pattern and poor combustion.

! NOTE !

Ensure that the nozzle is securely tightened so that it does not leak but DO NOT OVER TIGHTEN!

8. Re-fit the diffuser/electrode assembly. Refer to Figure 10-3.
 - Reconnect ignition leads (4) to electrodes.
 - Re-fit the diffuser/electrode assembly (5) onto the nozzle holder lining up the fixing screw with the recess in the nozzle holder.
 - Ensure diffuser assembly is fitted down hard onto the shoulder on the nozzle holder.
 - Tighten the fixing screw (3) to secure the diffuser/electrode assembly in place on the nozzle holder.

! NOTE !

Do not overtighten the fixing screw as this may damage the electrode insulator.

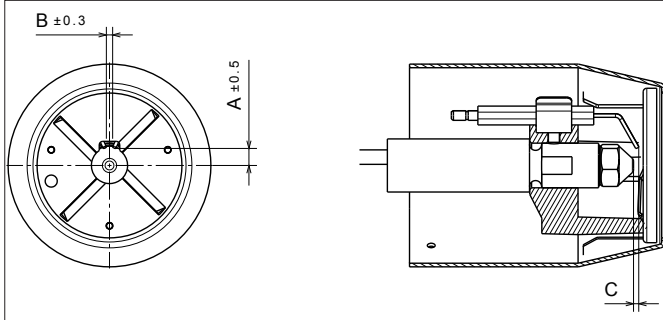

Figure 10-4: Ignition electrode settings

Model	A	B	C
Combi 21 and 26	7	2.5	2.5 - 3
Combi 36	4.5	3	2 - 2.5

Note: all dimensions given in mm

6. Check/adjust electrode setting. Refer to Figure 10-4.
7. Re-fit the burner head. Refer to Figure 10-3.
 - Locate the head fixing screws (1) in the countersunk slots in the burner collar.
 - Check that the small oil drip hole (on the head) is pointing downwards.
 - Tighten the three screws (1) to secure the head (2) in position on the burner.
8. Adjust the diffuser position. Refer to Figure 10-5.

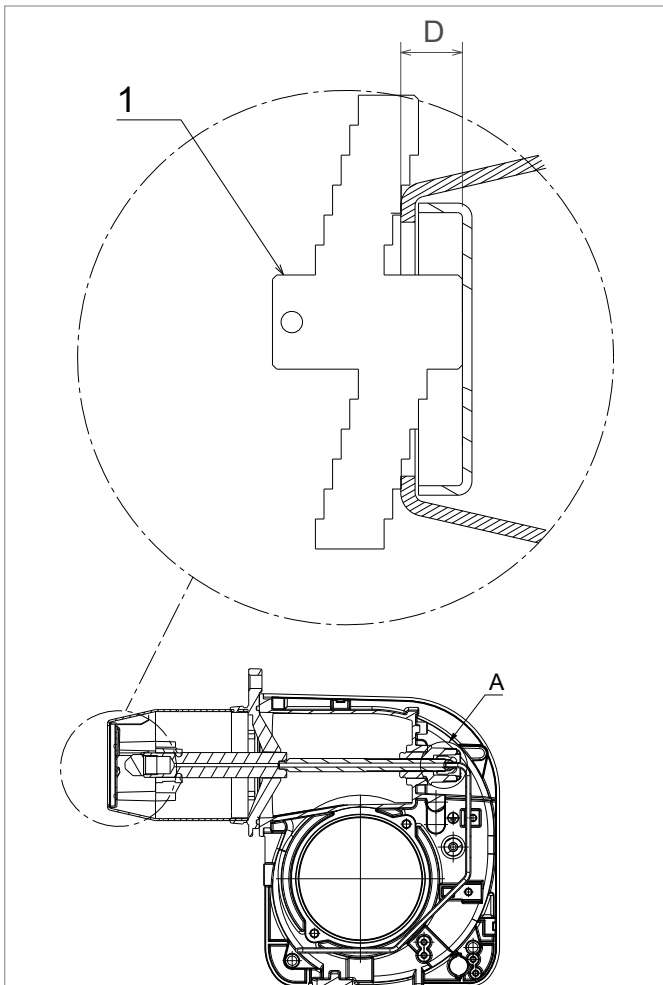

Figure 10-5: Riello RDB 2.2 BX diffuser position and gauge plate

! NOTE !

The distance between the end of the burner head and the front face of the diffuser (D) **MUST** be correctly set for the burner to operate correctly.

- Refer to Table 2-2 for the required distance (head setting) for the boiler output required.
- Check the distance D using the gauge plate supplied with the boiler.
- To use the gauge plate:
 - Position the gauge on the burner head as shown in Figure 10-5.
 - Locate the gauge with the correct steps (i.e. the two marked with the required distance D) resting on the edge of the burner head.
 - Check the gauge plate is at 90° to the end of the burner head and is positioned at the full diameter of the head.
 - If the distance D is correct, the tongue of the gauge plate should just make contact with the diffuser, with BOTH steps still in contact with the edge of the burner head.
 - If the steps are not in contact with the edge of the burner head, when the tongue of the gauge is touching the diffuser, the diffuser must be 'opened' (see below).
 - If the tongue does not reach the diffuser, when the steps are in contact with the edge of the burner head, the diffuser must be 'closed' (see below).
- To adjust the diffuser position:
 - If necessary, adjust distance D using the black adjustment knob located around the oil supply pipe on the front of the burner. Refer to item A (Figure 10-5). Re-check distance D using the gauge plate, as described above.
 - For easier access to the adjustment knob, pull the photocell out from the burner housing.
 - To increase distance D (to open the diffuser): rotate the knob clockwise - indicated as '+' on the knob.
 - To decrease distance D (to close the diffuser): rotate the knob anti-clockwise - indicated as '-' on the knob.

! NOTE !

One full rotation of the adjustment knob is approximately 1mm of diffuser movement.

! NOTE !

It is essential that the final position of the diffuser is checked, using the gauge plate provided with the boiler and the diffuser adjusted as necessary to achieve the required distance D.

9. For Combi 21 models only:
Check the burner air adjuster disc is correctly set. Refer to Section 10.3.

10.3 AIR ADJUSTER DISC: COMBI 21 ONLY

The Riello RDB 2.2 BX burner fitted to these boilers incorporates a secondary air adjustment.

This is an air adjuster disc located on the fan housing (inside the air inlet housing).

It is essential, for correct operation of the burner, that this internal air adjuster disc is correctly set. Refer to Figure 10-6.

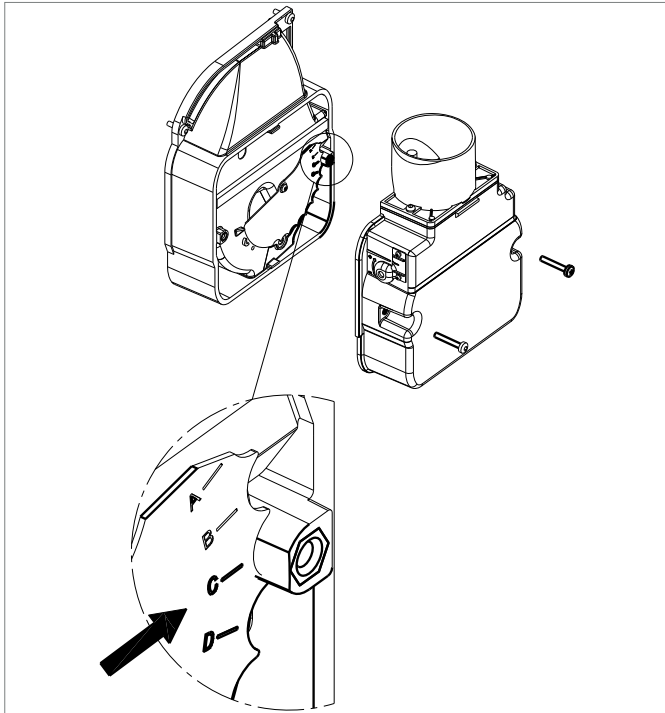

Figure 10-6: Air adjuster disc

To access the air adjuster disc:

1. Ensure the boiler is isolated from the electrical supply.
2. Remove the burner fixing nut (located at the top of the mounting flange) and withdraw the burner from the boiler.
3. Undo the two screws and remove the air inlet cover from the side of the burner.
4. The air adjuster disc is mounted on the fan housing. Refer to Figure 10-6.
5. Check that this disc is correctly set for the factory set output of the boiler, i.e. with the correct cut-out mark located against the moulded boss on the fan housing. Refer to Table 2-2 for correct disc settings. If the disc is not correctly set it **MUST** be re-positioned. Refer to step 6 below.
6. The air adjuster disc is re-positioned as follows:
 - Remove the screw from the centre of the air adjuster disc.
 - Re-position the disc so that the correct cut-out is located against the moulded boss on the fan housing.
 - Replace the screw in the centre of the air shutter disc and tighten.
7. Re-fit the air inlet cover to the side of the burner and secure in place using the two screws.

10.4 SWITCHING ON

1. Check that all system controls are calling for heat and turn the boiler thermostat to maximum.
2. Switch on the electricity supply to the boiler.
3. Set the boiler On/Off switch to ON. A neon on the switch lights when it is in the ON position. Note that the neon lights when the boiler is switched on, but does not necessarily indicate the burner is firing.

Set both the Hot Water and Heating switches to ON. The burner should then fire. Open the vent screw on the vent manifold to vent the supply while the oil pump is running

4. Fully open a hot tap and allow it to run for a few moments to vent the internal primary circuit. The Hot Water pump will operate and the burner should light within about 12 seconds. If the burner does not light and the 'Lock-out' reset button lights, wait for about 45 seconds then press the reset button to restart the ignition process. This procedure may have to be repeated during first lighting.
5. Close the hot tap. The burner will continue to fire to heat the primary water in the boiler or primary store until the required temperature is reached.

! NOTE !

Grant Vortex Combi boilers incorporate a "pump overrun" feature, within the control circuit board, that operates as follows:

- **When reheating the Primary Hot Water store:** the burner will cut out when the boiler reaches 83°C (as detected by the boiler "flow" thermistor).
- **If there is a demand for Central Heating:** the hot water "store" pump will run on for 90 seconds before it stops and the "central heating" pump then comes in.
- **If there is no demand for Central Heating:** the hot water "store" pump will continue to run until the temperatures in the Primary Hot Water store and the boiler have equalised. The adjustable Boiler thermostat on the control panel regulates the boiler temperature when in Heating mode only. The recommended flow temperature setting is 70°C.

The Primary Hot Water store temperature is controlled via the "store" thermistor and control circuit board. The control thermostat has NO influence on either the store temperature or the hot water temperature at the tap.

! NOTE !

The hot water pump will continue to run for a short period after the burner has stopped.

The boiler will now be operating in the central heating mode.

! NOTE !

The burner may not fire immediately in the central heating mode.

6. With the burner alight, check the fuel pressure. Refer to Section 2.2 (burner settings).
7. Adjust the pressure if necessary - refer to Section 11.8 (Burner Components).

! NOTE !

It is important that the oil pressure is correctly set.

8. Operate the boiler until it reaches normal operating temperature. Check oil supply/return pipe for leaks, rectifying where necessary.
9. Check the operation of the boiler thermostat. Ensure that by turning it anticlockwise it switches the burner off.
10. With the burner alight, re-check the fuel pressure and re-adjust if necessary. Turn the boiler off, remove the pressure gauge and replace the plug in the pump.
11. Ensure that there are no oil leaks, replace the burner cover.

10.5 RUNNING THE BOILER

1. Relight the boiler and allow it to run for at least 20 minutes.
2. Check the smoke number, if it is 0-1 then it is satisfactory.
3. Using a calibrated electronic flue gas analyser, set to the correct fuel, check the %CO₂ in the flue gases.

! NOTE !

To allow the boiler to be commissioned and serviced correctly a combustion test point is provided on the front cleaning door. Both the %CO₂ and smoke test may all be carried out using this test point.

This test point is not suitable for measuring boiler efficiency or conventional flue draught.

4. When using the test point on the cleaning cover note that the flue gas temperature reading will be higher than that measured in the flue thus resulting in an inaccurate efficiency reading. To obtain an accurate flue gas temperature and efficiency, the reading can only be measured outside through the low level flue terminal (or the test point on the conventional flue starter section when used).
5. For high level and vertical balanced flues, the reading may be taken from the flue test point provided on the flue system.
6. For conventional flues, a test point is provided in the conventional flue adaptor for flue draught and flue gas temperature measurement.
7. Set the %CO₂, as indicated on the flue gas analyser, to the required value as given in Section 2.2 for the boiler concerned.
8. Adjust the burner air damper, using the hexagonal key supplied, to achieve the required %CO₂. Refer to Section 11.8.
9. To increase the %CO₂:
 - Turn the screw anti-clockwise. This will close down the burner air damper and decrease the combustion air entering the burner.To decrease the %CO₂:
 - Turn the screw clockwise. This will open up the burner air damper and increase the combustion air entering the burner.
10. When the %CO₂ is set to the correct level, re-check the smoke number if the burner air damper has been moved. Under no circumstances must the smoke number be above 1.

! NOTE !

For safe and efficient operation of the boiler it is essential that the air damper is correctly set to give the required %CO₂ in the flue gases.

10.6 BALANCING THE SYSTEM

1. When the boiler has been adjusted and is running satisfactorily, balance the central heating system by adjusting the radiator lock shield valves.
Start with the radiator nearest the boiler and adjust the valves to achieve the required temperature drop across each radiator.
If thermostatic radiator valves have been installed, check the system bypass.
2. Switch off the boiler.

10.7 COMPLETION

1. With the system hot, check again for leaks, rectifying where necessary. Drain the system while it is hot to complete the flushing process. Refill and vent the sealed system.
2. A suitable central heating system inhibitor must be added to protect the system against the effect of corrosion.
3. A suitable antifreeze should be used to prevent damage to the boiler in areas where electrical power failure can occur in winter months.
4. Replace the top, front and rear panels as necessary.

! NOTE !

After commissioning the boiler complete the OFTEC CD/11 commissioning report. Leave the top copy with the user and retain the carbon copy.

If the boiler is to be left in service with the User, set the controls and room thermostat (if fitted) to the User's requirements.

If the boiler is not to be handed over immediately, close the boiler fuel supply valve and switch off the electricity supply.

! CAUTION !

If there is any possibility of the boiler being left during freezing conditions, then the boiler and system should be drained. Alternatively, a suitable heating system antifreeze should be used.

10.8 INFORMATION FOR THE USER

The User must be advised (and demonstrated if necessary) of the following important points:-

- How to start and switch off the boiler and how to operate the system controls.
- The precautions necessary to prevent damage to the central heating system and to the building, in the event of the boiler not being in operation during frost conditions.
- The importance of servicing the boiler to ensure safe and efficient operation. This should normally be required only once a year.
- The type of fuel used.
- That any servicing or replacement of parts must only be carried out by a suitably qualified engineer.
- Ensure that the boiler controls and room thermostat (if fitted) are set to the User's requirements.
- Tell the User the system pressure and show them the position of the safety valve discharge pipe.
- Show the User how to reset the overheat thermostat and how to restart the boiler if it goes to 'Lockout'.

11 SERVICING

To ensure safe and efficient operation it is essential that a Grant Combi boiler is serviced at regular intervals of no longer than 12 months.

Servicing and replacement of parts must only be carried out by a suitably qualified engineer.

! CAUTION !

Details of every service should be entered in the Service Log, in the Boiler Handbook.

This information may be required to validate the Grant extended guarantee.

! WARNING !

Before starting any work on the boiler or fuel supply, please read the Health and Safety information given in Section 15 of these Instructions.

11.1 CHECKS BEFORE SERVICING

The following sequence of checks should be made before starting any servicing work:

1. Check the flue terminal and ensure it is not blocked or damaged.
2. Run the boiler and check the operation of its controls.
3. Ensure that all water system connections and fittings are sound. Remake any joints and check the tightness of any fittings that may be leaking.
4. Allow the boiler and system to cool down.
5. The boiler is part of a sealed central heating system, check the system pressure, check the operation of the pressure relief valve and check the expansion vessel air charge. Refer to Section 7.
6. Refill, vent and re-pressurise the system as necessary. Refer to Section 7.
7. Check that the ventilation holes in the front casing door are clear of obstructions. See Section 9.
8. Remove any sludge/water from the fuel tank by opening the sludge valve at the lower end of the tank (if fitted).
9. Ensure that all fuel system connections and fittings are sound. Remake any joints and check the tightness of any fittings that may be leaking.
10. With the fuel supply valve (at the oil tank) closed, clean/replace the filter element and clean the filter bowl.

! WARNING !

Before servicing, set the boiler ON/OFF switch to OFF, isolate the electricity supply and close the fuel supply valve.

The data label on the inside of the case side panel will indicate the fuel used and the nozzle fitted.

11.2 DISMANTLING PRIOR TO SERVICING

The procedure for dismantling the boiler is as follows:

1. Remove the front casing door by turning the handle and pulling forward at the bottom.
2. Remove the four screws retaining the top casing panel and carefully lift it off, taking care not to damage the insulation.

! NOTE !

The top panel has been designed to provide a slight fall away from the side positioned against a wall. Please refer to Figure 4-1 for further details.

3. Carefully lift up the expansion vessel and remove it from the boiler. Place it on the floor, taking care not to strain the flexible pipe.
4. Unscrew and remove the two fixing screws and remove the red cover from the burner.
5. Remove the burner fixing nut (located at the top of the mounting flange) and withdraw the burner from the boiler. If required, disconnect the flexible oil line(s), using a suitable container to prevent any oil spillage.
6. Check or replace the flexible fuel supply hose, as follows:
 - Braided flexible fuel supply hoses (as supplied with the boiler) should be replaced annually, i.e. when the boiler is serviced.
 - Long-life hoses should be inspected annually. If in doubt replace the hose(s). In any event, these hoses must be replaced every five years.

! NOTE !

With a two-pipe oil supply there will be two flexible hoses connected to the burner. Identify (mark if necessary) which is the inlet and return if they are to be disconnected.

11.3 CLEANING THE BOILER

The procedure for cleaning the boiler is as follows:

1. Remove the nuts and washers securing the front cleaning door and withdraw the door. Take care - it is heavy.
2. Remove the baffles as shown in Figure 11-1, Figure 11-2 and Figure 11-3.
3. Remove all deposits from the baffle plates and all the boiler internal surfaces using a stiff brush and scraper if necessary.
4. Check the condition of the flue, clean as necessary.
5. Check the condition of the front cleaning door seal and replace if necessary.
6. Replace the baffles, ensuring they are correctly fitted. Refer to Figures 11-1 to 11-3, as appropriate.
7. Pull out the spiral turbulators from the heat exchanger tubes. See Figure 11-4. Clean the turbulators using a stiff brush.
8. Test the heat exchanger condensate drain by pouring water into one of the lower tubes and observe whether the water discharges from the 22 mm condensate outlet. Replace the turbulators.
9. Replace the front cleaning door, ensuring the seal is in good condition and secure it in position with the nuts and washers previously removed. Tighten to form a seal.
10. Remove the condensate trap and check that it is not blocked and is operating correctly, i.e. the float is free to move. Clean the trap and float as required.
11. Check the condition of the flexible condensate hose between the trap and the boiler.
12. Check that the boiler condensate outlet is unobstructed. Clean if necessary.

! NOTE !

The condensate trap and condensate outlet must be checked on every service and cleaned as necessary. The end cap is not sealed to the trap body and can be removed for cleaning. Ensure that this cap is correctly re-fitted before re-starting the boiler.

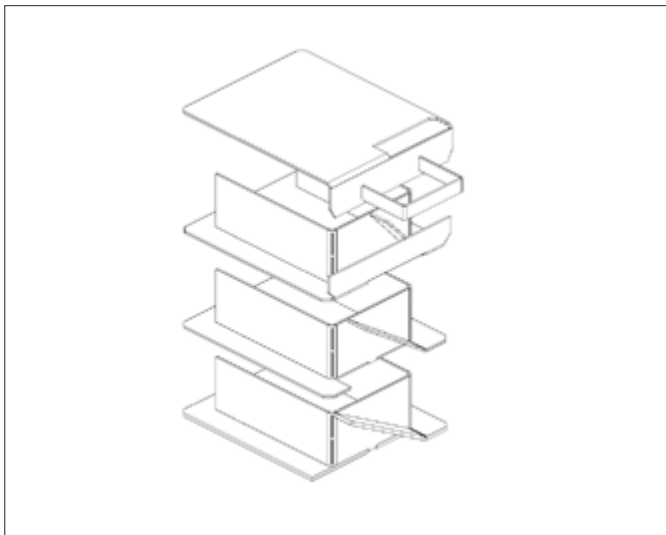

Figure 11-1: Baffles in Vortex Pro External Combi 21

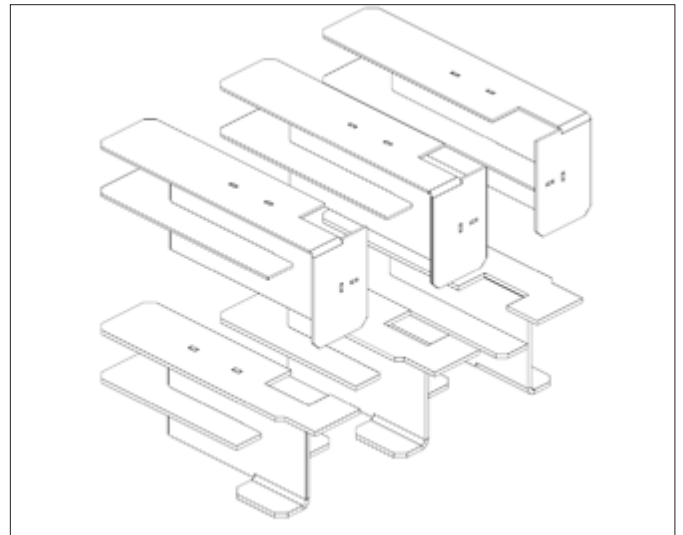

Figure 11-3: Baffles in Vortex Pro External Combi 36

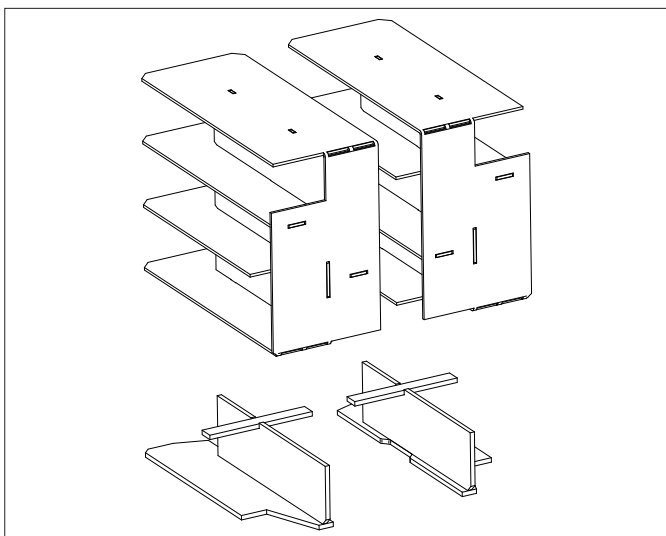

Figure 11-2: Baffles in Vortex Pro External Combi 26

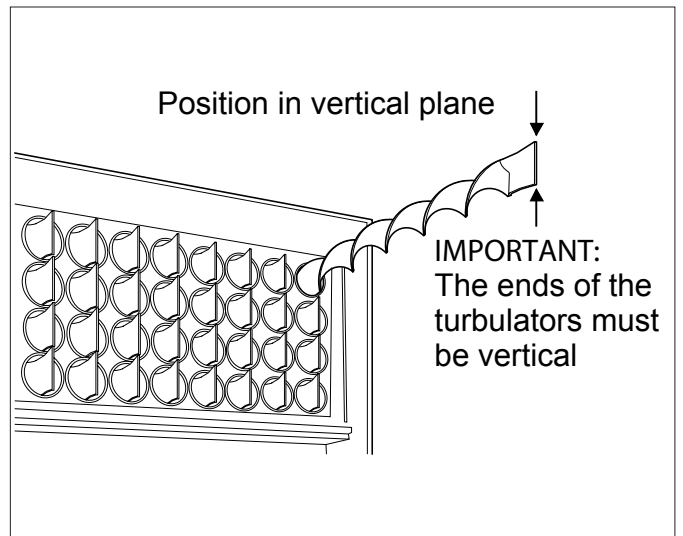

Figure 11-4: Turbulators

11.4 CLEANING THE BURNER RDB2.2 BX BURNERS

With the burner removed from the boiler:

Burner head, nozzle and diffuser/electrode assembly

1. Remove the burner head. Refer to Figure 10-3. Loosen the three fixing screws (1) and remove head (2) from burner.
2. Clean the combustion head.
3. Remove diffuser/electrode assembly. Refer to Figure 10-3.
 - Using a 4 mm Allen key, loosen the diffuser fixing screw (3) from electrode assembly.
 - Lift diffuser/electrode assembly (5) up and off the nozzle holder.
 - Disconnect both ignition leads (4) from the electrodes.
4. Replace the nozzle (8). The nozzle should always be replaced on an annual service. Refer to Table 2-2 for the correct nozzle size and type for the required boiler output. Do NOT attempt to clean the nozzle.
 - Use a 16 mm spanner to remove/re-fit the nozzle, whilst holding the nozzle holder using a 19 mm spanner.

! CAUTION !

The use of an ill-fitting spanner will damage the nozzle and could lead to an incorrect flame pattern and poor combustion.

! NOTE !

Ensure that the nozzle is securely tightened so that it does not leak but do not overtighten.

5. Inspect the ignition electrodes - remove the diffuser fixing screw and withdraw the electrode assembly. Wipe clean and check for any cracks in the ceramic insulation. Replace if necessary.
6. Re-fit the diffuser/electrode assembly. Refer to Figure 10-3.
 - Reconnect ignition leads (4) to electrodes.
 - Re-fit the diffuser/electrode assembly (5) onto the nozzle holder lining up the fixing screw with the recess in the nozzle holder.
 - Ensure diffuser assembly is fitted down hard onto the shoulder on the nozzle holder.
 - Tighten the fixing screw (3) to secure the diffuser/electrode assembly in place on the nozzle holder.

! NOTE !

Do not overtighten the fixing screw as this may damage the electrode insulator.

7. Check/adjust the electrode settings. Refer to Figure 10-4. Always check the electrode settings after replacing the nozzle.
8. Re-fit the burner head. Refer to Figure 10-3.
 - Locate the head fixing screws (1) in the countersunk slots in the burner collar.
 - Check that the small oil drip hole (on the head) is pointing downwards.
 - Tighten the three screws (1) to secure the head (2) in position on the burner.
9. Adjust the diffuser position. Refer to Section 11-5.

Photocell

The photocell is a push-fit in the front of burner body. Refer to Section 11.8 (burner components).

1. Holding the body of the photocell (4) and NOT the cable, carefully pull the photocell out of the burner.
2. Clean the sensor end of the photocell.
3. Replace photocell back in the burner and check that it is fully pushed in.

Burner air inlet cover

This is located on the right hand side of the burner. Refer to Section 11.8 (burner components).

1. Unscrew and remove the two screws and remove the air inlet cover from the burner.
2. Check inside and remove any debris, leaves, hair, fluff, etc. from the air inlet cover and air damper.
3. Check the condition of the rubber seal around the air inlet cover. Replace if damaged or missing.

Burner fan housing

This is located over the fan impeller. Refer to Section 11.8 (burner components).

With the Burner air inlet cover already removed:

1. Unscrew and remove the four screws and remove the fan housing from the burner.
2. Check and clean the fan impeller and remove any debris, leaves, hair, fluff etc.
3. Check the fan housing is clean and clean as required.
4. Check the rubber seal around the fan housing. Replace if damaged or missing.
5. Re-fit the fan housing to the burner and secure with the four screws.
6. Check the air adjuster disc (Combi 21 only). Refer to Section 11.6 for details.
7. Re-fit the air inlet cover to the burner and secure with the two screws.

Oil pump filter

This is located under the end cover on the oil pump. Refer to Section 11.8 (burner components).

1. Unscrew and remove the four cap screws securing the pump end cover.
2. Remove the filter and wash in kerosene.
3. Check the O-ring seal around the end cover. Replace if damaged.
4. Replace the filter and end cover.
5. Re-fit the four cap screws, tightening evenly, to secure the end cap.

11.5 ADJUSTING THE DIFFUSER

Adjust the diffuser position. Refer to Figure 10-5.

! NOTE !

The distance between the end of the burner head and the front face of the diffuser (D) MUST be correctly set for the burner to operate correctly.

- Refer to Table 2-2 for the required distance (head setting) for the boiler output required.
- Check the distance D using the gauge plate supplied with the boiler.
- To use the gauge plate:
 - Position the gauge plate on the burner head as shown in Figure 10-5.
 - Locate the gauge plate with the correct steps (i.e. the two marked with the required distance D) resting on the edge of the burner head.
 - Check the gauge plate is at 90° to the end of the burner head and is positioned at the full diameter of the head.
 - If distance D is correct, the tongue of the gauge plate should just make contact with the diffuser with BOTH steps still in contact with the edge of the burner head.
 - If the steps are not in contact with the edge of the burner head when the tongue of the gauge plate is touching the diffuser, the diffuser must be 'opened' (see below).
 - If the tongue does not reach the diffuser when the steps are in contact with the edge of the burner head, the diffuser must be 'closed' (see below).
- To adjust the diffuser position:
 - If necessary, adjust distance D using the black adjustment knob located around the oil supply pipe on the front of the burner. Refer to item A (Figure 10-5). Re-check distance D using the gauge plate, as described above.
 - For easier access to the adjustment knob, pull the photocell out from the burner housing.
 - To increase distance D (to open the diffuser): rotate the knob clockwise - indicated as '+' on the knob.
 - To decrease distance D (to close the diffuser): rotate the knob anti-clockwise - indicated as '-' on the knob.

! NOTE !

One full rotation of the adjustment knob is approximately 1 mm of diffuser movement.

! NOTE !

It is essential that the final position of the diffuser is checked, using the gauge plate provided with the boiler and the diffuser adjusted as necessary to achieve the required distance D.

11.6 AIR ADJUSTER DISC: COMBI 21 ONLY

Refer to Section 10.3.

11.7 RECOMMISSIONING

! WARNING !

To ensure safe and efficient operation of the boiler it is important that re-commissioning is carried out, especially combustion checks (%CO₂ level, flue gas temperature and smoke number) after the boiler has been serviced. Refer to the Commissioning instructions in Section 10.

11.8 BURNER COMPONENTS COMBI 21, COMBI 26 AND COMBI 36 (RIELLO RDB 2.2 BX)

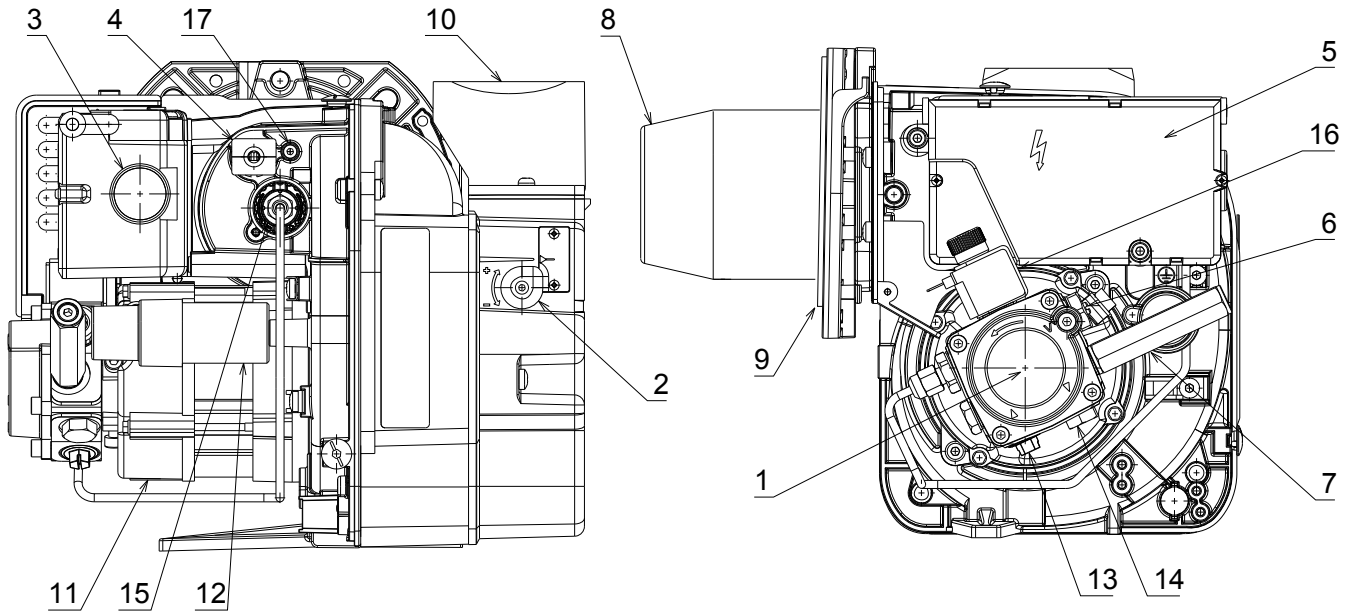

Item	Description	Item	Description
1	Oil pump	10	Air inlet
2	Air damper adjustment screw	11	Motor
3	Reset button with lockout lamp	12	Motor ignition capacitor
4	Photocell	13	Fuel suction line
5	Control box	14	Return line
6	Pump pressure adjustment screw	15	Combustion head adjustment handle
7	Extension for gauge connection	16	Coil
8	Combustion head	17	Air pressure test point
9	Flange with insulating gasket		

12 FAULT FINDING

12.1 INITIAL CHECKLIST - FOR INSTALLERS OR SERVICE ENGINEERS

12.1.1 IF THE BOILER FAILS TO LIGHT

First follow the procedure below

Power supply	Check that the fused spur for the heating system is switched on. Check that the fuse has not blown. Check that the electricity supply has not failed; check circuit breaker in consumer unit.
Heating system controls	Check that the timer or programmer is working and set to an 'ON' period. Check that all thermostats are set to the required temperature and are 'calling' for heat.
Boiler controls	Check that the boiler 'ON/OFF' switch is set to 'ON'. Check that the 'POWER' demand indicator on the control panel is lit. Check that the 'DEMAND' indicator is lit.
Burner	Check if the burner lockout reset button (on front face of burner) is lit. If YES: press in the reset button to start the burner. If burner fails to light and goes to lockout again, refer to Section 12.4.
If burner still fails to light	Follow the 'burner not operating' procedure in Section 12.2 (C).

12.1.2 FOR HOT WATER - ALL THE FOLLOWING INDICATOR LIGHTS MUST BE LIT

POWER	If not lit, this indicates a problem with the power supply to the boiler - switched off or possibly blown a fuse.
DHW PUMP	If flashing, this indicates either a 'store' thermistor or PCB fault. Refer to the 'is the DHW PUMP indicator flashing' procedure in Section 12.2 (B).
FLOW	If not lit when a hot tap is opened, this indicates either a lack of water flow or possible flow switch problem.
DEMAND	If not lit, this indicates either timer/programmer is not 'calling' for hot water or 'hot water' switch is not set to 'constant'.
BURNER	If flashing, this indicates a PCB fault. Refer to the 'is the burner indicator lit' procedure in Section 12.2 (B).

NOTE: There may be a delay before the 'burner' indicator is lit when the store is up to temperature

12.1.3 FOR NIGHT TIME HOT WATER FUNCTION - ALL THE FOLLOWING INDICATOR LIGHTS MUST BE LIT

POWER	If not lit, this indicates a problem with the power supply to the boiler - switched off or possibly blown a fuse.
DHW PUMP	If flashing, this indicates either a 'store' thermistor or PCB fault. Refer to the 'is the DHW PUMP indicator flashing' procedure in Section 12.2 (B).
FLOW	If not lit when a hot tap is opened, this indicates either a lack of water flow or possible flow switch problem.
DEMAND	If not lit, this indicates either timer/programmer is not 'calling' for hot water or 'hot water' switch is not set to 'constant'.
BURNER	If flashing, this indicates a PCB fault. Refer to the 'is the burner indicator lit' procedure in Section 12.2 (B).

NOTE: The 'DHW PUMP' indicator may be lit if the boiler is operating to heat the store which has priority over the central heating operation.
There may be a delay before the 'BURNER' indicator is lit when the store is up to temperature.
For further guidance, refer to Section 12.2 (main fault finding procedures).

12.2 MAIN FAULT FINDING PROCEDURES

A NO CENTRAL HEATING - BUT HOT WATER OK

First, set the hot water switch to OFF

Is the 'DEMAND' indicator lit?	NO	Check programmer/timer and room thermostat are calling for heating.
	NO	Checking 'heating' switch is set to 'TIMED'.
Is the 'CH PUMP' indicator lit?	YES PCB is supplying voltage to the CH pump but the pump is not working.	Check electrical connections at the pump. Check for 230V at the pump terminals. Check if CH pump is stuck: <ul style="list-style-type: none"> • Check for rotation of shaft/impellar. • If still not operating, replace the CH pump.
	YES CH pump is not but there is no circulation.	Check both pump valves are open. Check non-return valve on CH pump is operational (not sticking). Check there are no air locks in the system (if removal of air is difficult - see additional check list).
Is the 'CH PUMP' indicator lit?	NO	Check the non-return valve on the CH pump - is it stuck blocked open - check/rectify. NOTE: CH return will be better than flow if CH non-return valve is jammed open. Check by closing one heating pump valve to stop circulation - does the store then come up to temperature? If the problem is not due to CH non-return valve - continue to the next check.
Is the 'CH PUMP' indicator flashing?	YES Fast or slow flash	First, set boiler 'ON/OFF' switch to 'OFF'. Wait 5 seconds Then set 'ON/OFF' switch back to 'ON'.
If the 'CH PUMP' indicator continues flashing?	Fast flash (twice per second): Indicates a possible fault with the 'flow' thermistor.	Check CH 'flow' thermistor connection to the PCB. Replace 'flow' thermistor.
	Slow flash (once every 2 seconds): Indicates a possible fault with the PCB relay.	Replace PCB
Is the 'BURNER' indicator lit?	YES	Is the burner firing? If no: refer to 'burner not operating' procedure in Section 12.2 (C).

B NO HOT WATER - BUT CENTRAL HEATING OK

First, set the heating switch to OFF

Is the 'DEMAND' indicator lit?	NO	Check programmer is calling for hot water. If no programmer is fitted: check 'hot water' switch is set to 'CONSTANT'.
	NO	Check 'heating' switch is set to 'TIMED'.
Is the 'FLOW SWITCH' indicator lit?	NO	Check hot water tap is open. Check water flow rate is at least 3 litres/minute.
	Cannot achieve 3 litres/minute	Check the mains stop tap is open fully. Check the cold water isolation valve in the boiler is open. Check if the flow restrictor (located in the cold water isolation valve) is clear. If not, clean restrictor or remove from valve. NOTE: No flow restrictor is fitted to the Combi 36 model.
	Is the water pressure OK? Low water pressure = low water flow rate.	Check standing water pressure. 2 bar minimum standing pressure required. Check running (dynamic) pressure. 1 bar minimum dynamic pressure required.
	If water pressure is OK.	Check for blockage in plate heat exchanger unit. NOTE: In hard water areas, scale will be produced that can block the plate heat exchanger if no anti-scale protection has been installed. Refer to Section 5 for further details.
Is the 'FLOW SWITCH' indicator lit?	Is plate heat exchanger is OK.	Check flow switch is correctly positioned: the arrow (on flow switch body) must point in the direction of flow, i.e. toward the front of boiler. Check switch is free to operate: close cold water isolation valve, remove flow switch from pipework - manually operate switch paddle to check. Remove any debris/blockage from the pipework body or switch paddle. Check for electrical continuity between flow switch terminals when switch is closed. No continuity - replace flow switch. No 230V - check connections at PCB. If still no 230V - replace PCB.
		Flow switch is activated. Continue to the next check.
Is the 'DHW PUMP' indicator lit?	NO	Continue to next check.
Is the 'DHW PUMP' indicator flashing?	YES Fast or slow flash	First, set boiler 'ON/OFF' switch to 'OFF'. Wait 5 seconds. Then set 'ON/OFF' switch back to 'ON'.
	Fast flash (twice per second): Indicates a possible fault with the 'store' thermistor.	Check DHW 'store' thermistor connection to PCB. Replace 'store' thermistor.
If the 'DHW PUMP' indicator continues flashing.	Slow flash (once every 2 seconds): Indicates a possible fault with the PCB (relay).	Replace PCB.
	YES PCB is supplying voltage to the DHW pump - but pump is not working.	Check for electrical connections at the pump. Check for 230V at the pump terminals. Check if CH pump is stuck: <ul style="list-style-type: none"> • Check for rotation of shaft/impeller. • If still not operating, replace the DHW pump.
Is the 'DHW PUMP' indicator lit?	YES DHW pump is working but no circulation.	Check both pump valves are open. Check non-return valve on DHW pump is operational (not sticking). Check there are no air locks in the system (if removal of air is difficult - see additional check list).
	YES DHW pump is working and water is circulating.	Hot or warm water should be present at hot tap. If not: refer to 'poor hot water' procedure in Section 12.3.
	YES	Is burner firing? If no: refer to 'burner not operating' procedure in Section 12.2 (C).

C BURNER NOT OPERATING

First, set either hot water or heating to ON

Is the 'BURNER' indicator lit?	NO	Refer to 'initial checklist' for guidance.
	NO	Continue to next check.
Is the 'BURNER' indicator flashing?	YES	First, set boiler 'ON/OFF' switch to 'OFF'. Wait 5 seconds Then set 'ON/OFF' switch back to 'ON'.
	Fast or slow flash.	
If the 'BURNER' indicator continues flashing.	Slow flash (once every 2 seconds):	Replace PCB
	Indicates a possible fault with the PCB (relay).	
Is the 'BURNER' indicator lit?	YES	Check all electrical connections to burner control box. Check for 230V at L and N terminals in control box.
	PCB is supplying voltage to the burner - but the burner is not working.	Is 'lockout' button (on control box) lit? If yes: press 'lockout' button to reset burner. If burner does not fire, refer to Section 12.4 (burner fault finding).

12.3 POOR HOT WATER CHECKLIST

Always check the basics before changing parts.

Burner	If heat energy input is incorrect: heat energy output will be incorrect.	Check nozzle is correct size.
	Poor heat input = poor hot water.	Check oil pump pressure is correct. Check combustion is correctly set.
DHW pump	Plate heat exchanger requires water circulation from primary store to operate.	Check pump speed setting: it must be maximum. Check pump valves are fully open.
Thermistors	DHW 'store' and CH 'flow' thermistors must detect temperatures correctly.	Check both are fully inserted in their pockets.
Water flow rate at hot tap	Excessive flow rate exceeds heat input from burner.	Check flow rate at tap. Combi 21 = 12 litres/minute maximum. Combi 26 = 15 litres/minute maximum. Combi 36 = 18 litres/minute maximum.
	Excessive flow rate = poor hot water.	
Water pressure	Excessive pressure has a major influence on flow rate.	Check standing and operating water pressure. 2 bar minimum standing pressure required. 8 bar maximum standing pressure. If greater than 8 bar; fit a pressure reducing valve on the cold supply to the boiler. 1 bar minimum dynamic pressure required.
Water condition	Scale forming in the plate heat exchanger = poor heat transfer in plate = poor hot water temperature.	Check for scale in the plate heat exchanger. Replace plate heat exchanger if necessary. In hard water areas some form of anti-scale device or water softener must be fitted. NOTE: Faults due to hard water scaling are not covered by the product guarantee.
Thermostatic blending valve	Must be correctly set to provide optimum hot water.	Check if blending valve is scaled up (refer to 'water condition' above). Clean or replace as necessary.

! NOTE !

For an overview of the fault diagnostic capabilities built into the circulating pumps that come installed in all Vortex Pro Combi models, please refer to Appendix A1 or A2, as required, at the back of this installation and servicing manual.

12.4 BURNER FAULT FINDING - RIELLO RDB BURNERS

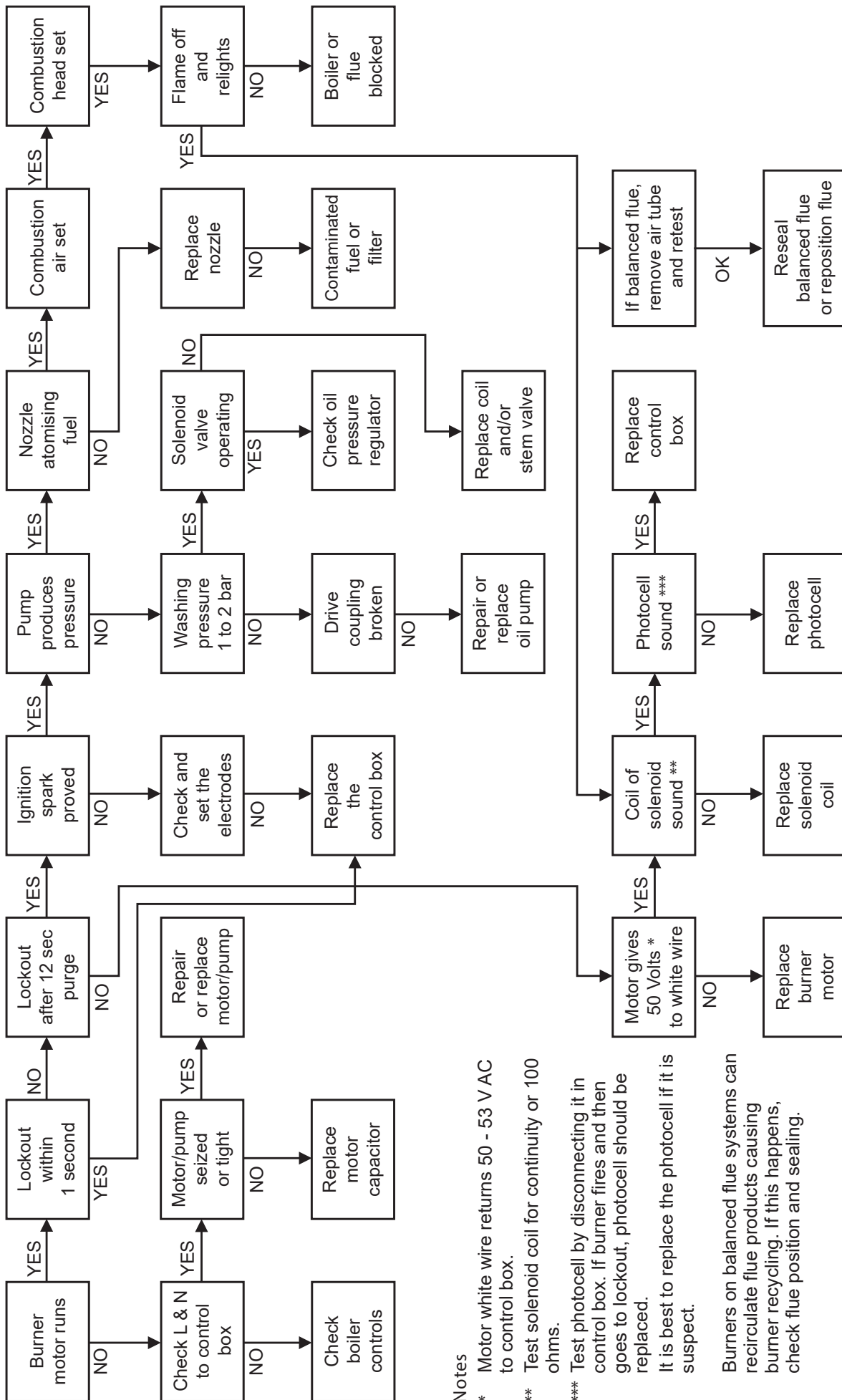

Notes

* Motor white wire returns 50 - 53 V AC to control box.

** Test solenoid coil for continuity or 100 ohms.

*** Test photocell by disconnecting it in control box. If burner fires and then goes to lockout, photocell should be replaced. It is best to replace the photocell if it is suspect.

Burners on balanced flue systems can recirculate flue products causing burner recycling. If this happens, check flue position and sealing.

13 SPARE PARTS

13.1 BOILER PARTS LIST

Table 13-1: Boiler parts list

Description	Grant UK product code
Cleaning door nut and washer set	EFBS14
Double pole switch	EFBS19
Baffle set (complete) - Combi 21	VBS93
Baffle set (complete) - Combi 26	VBS01
Baffle set (complete) - Combi 36	VBS36
Turbulator baffle - 360 mm (single) - all models	VBS05
Combustion Door - all Combi models Post July 2017	MPCBS110B
Cleaning door rope seal - Combi 21 and 26	VBS15
Cleaning door rope seal - Combi 36	VBS16
Limit thermostat (110°C) c/w Earth wire	VBS147
Wilo Yonos Para RKC HE circulating pump (7 m head) - all models between April 2015 and November 2019	VBS126
Willo Para SC HE circulating pump (7m head) - all models from November 2019	VBS159
Control Panel - External Combi models Post 01.11.2016	MPCBS105N
Control Panel 5 Pin Plug - Female	MPCBS105A
Control Panel 5 Pin Plug - Male	MPCBS105B
Temperature Control PCB (c/w sensors) - all Combi models Post Sept 2008	MPCBS54E
Temperature Control PCB (w/o sensors) - all Combi models Post Sept 2008	MPCBS96
Direct H/W Sensor for PCB - all Combi models Post Sept 2008	MPCBS98
Central Heating Sensor for PCB - all Combi models Post Sept 2008	MPCBS97
Manual Air Vent - All Combi Models	MPCBS68
Automatic Air Vent	MPCBS29
Plate Heat Exchanger	MPCBS53A
Thermostatic Mixing Valve	MPCBS22F
Flow Switch - All Combi models post 15.05.2008	MPCBS71X
Single Pole Low Pressure Switch	MPCBS49X
Non-Return Check Valve (28mm) - all Combi models Post April 2011	MPCBS81B
Pump Valve pair (22mm) - Combi 21 and 26	MPCBS69
Pump Valve pair (28mm) - Combi 36	MPCBS64

13.2 SEALED SYSTEM PARTS LIST

Table 13-2: Sealed system parts list

Description	Grant UK product code
Expansion vessel (24 litre)	VBS124
Water pressure gauge	VBS08
Pressure relief valve (2.5 bar)	MPCBS50
Expansion vessel flexible hose - all Combi models Post Dec 2014	VBS125
Filling Loop Kit (c/w valves)	MPCBS30

13.3 RIELLO RDB 2.2 BX BURNERS

This section gives exploded views of the Riello burners in the Grant Vortex boilers, and parts lists associated with them.

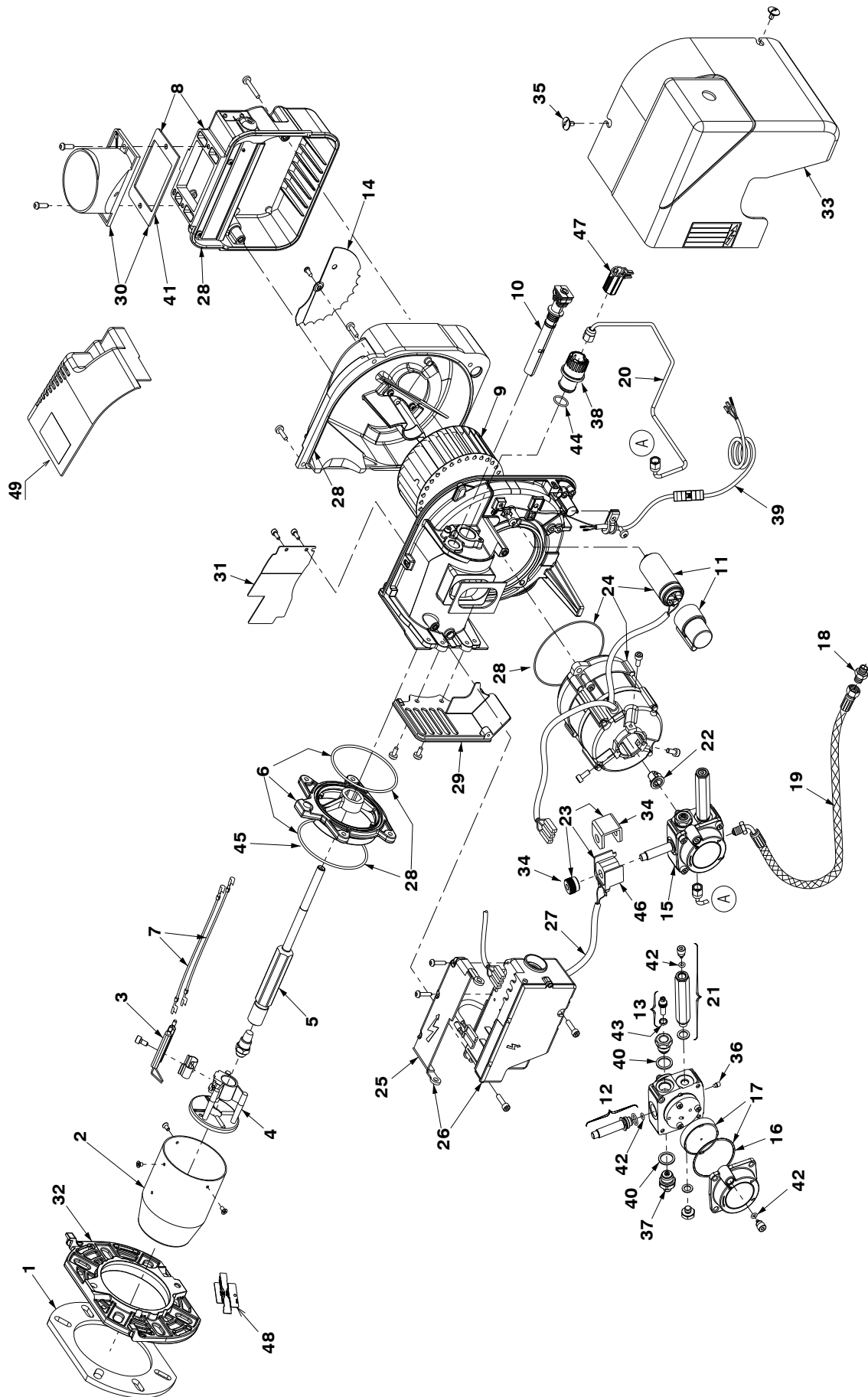

Figure 13-1: Riello RDB 2.2 BX burner exploded diagram

Table 13-3: Riello RDB 2.2 BX burner parts list

Key No.	Combi 21	Combi 26	Combi 36	Description	Riello product code	Grant product code
1	•	•	•	Flange gasket	3005787	RBS27
2	•	•	•	Combustion head	20147320	Z20147320
3	•	•	•	Electrode	20018545	Z20018545
				Electrode	20018693	Z20018693
4	•	•	•	Diffuser disc	20139837	Z20139837
				Diffuser disc	20133586	Z20133586
5	•	•	•	Nozzle holder	20133588	Z20133588
6	•	•	•	Collar	20141540	Z20141540
7	•	•	•	High voltage lead	20119415	Z20119415
8	•	•	•	Air damper assembly	20089768	Z20089768
9	•	•	•	Fan	3005788	RBS151
10	•	•	•	Flame sensor	20132526	Z20132526
11	•	•	•	Capacitor	20071576	RBS149A
12	•	•	•	Needle valve	3007871	RBS109
13	•	•	•	Regulator	3008651	Z3008651
14	•	•	•	Air damper	20094349	Z20094349
15	•	•	•	Circulating pump	20030953	RBS101
16	•	•	•	O-ring	3007175	RBS08
17	•	•	•	O-ring and filter	3020436	RBS122
18	•	•	•	Connector	3003602	Z3003602
19	•	•	•	Hose	3005720	Z3005720
20	•	•	•	Tube	20018549	Z20018549
21	•	•	•	Extension	3008876	RBS138
22	•	•	•	Coupling	3000443	RBS16
23	•	•	•	Coil	3008648	RBS117
24	•	•	•	Motor and capacitor	20071577	RBS102A
25	•	•	•	Protection	3008649	Z3008649
26	•	•	•	Control box	3008652	RBS103
27	•	•	•	Connection	3008851	RBS139
28	•	•	•	Seals kit	20040600	Z20040600
29	•	•	•	Front shield	3020306	Z3020306
30	•	•	•	Air intake	3020281	Z3020281
31	•	•	•	Bulkhead	20081612	Z20081612
32	•	•	•	Front piece	3006384	RBS119

Table 13-3: Riello RDB 2.2 BX burner parts list (continued)

Key No.	Combi			Description	Riello product code	Grant product code
	21	26	36			
32	•	•	•	Front piece	3006384	RBS119
33	•	•	•	Cover	3008879	RBS141
34	•	•	•	Shell and knob	3007566	Z3007566
35	•	•	•	Screw	20119098	Z20119098
36	•	•	•	Bypass screw	20029299	RBS56P
37	•	•	•	Connector	3020076	Z3020076
38	•	•	•	Knob	20134372	Z20134372
39	•	•	•	Connection	20140287	Z20140287
40	•	•	•	Seal	3007087	Z3007087
41	•	•	•	Seal	3020086	Z3020086
42	•	•	•	O-ring	3007177	Z3007177
43	•	•	•	O-ring seal	3007028	Z3007028
44	•	•	•	O-ring	3007167	Z3007167
45	•	•	•	O-ring	3007178	RBS31
46	•	•	•	Coil	3007565	Z3007565
47	•	•	•	Index	20147023	Z20147023
48	•	•	•	Gauge plate	-	Contact Grant UK
49	•	•	•	Conventional Flue Air Intake	20012046	Z20012046

14 DECLARATION OF CONFORMITY

EC DECLARATION OF CONFORMITY

In accordance with BS EN ISO/IEC 17050-1:2004

We: Grant Engineering (UK) Limited

Of: Hopton House
Hopton Industrial Estate
Devizes
SN10 2EU

Telephone: +44 (0)1380 736920

Fax: +44 (0)1380 736991

Email: info@grantuk.com

Website: www.grantuk.com

Declare that:

Equipment: Domestic oil boilers

Model Name/Number: Grant Vortex Outdoor Combi 21, 26 and 36

Note: All Grant Combi variants are supplied with glandless high efficiency integrated circulators

In accordance with the following Directives:

2006/95/EEC Conforms with the safety objectives of the Low Voltage Directive and its amending directives.

2004/108/EC Conforms with the essential protection requirements of the Electromagnetic Compatibility Directive and its amending directives.

92/42/EC Conforms with the requirements of the Boiler Efficiency Directive.

2010/30/EU Conforms with the Labeling of Energy related products to EU (no) 811/2013

2009/125/EC Conforms with the Ecodesign of Energy related products to EU (no) 813/2013

I hereby declare that the equipment named above has been tested and found to comply with the relevant sections of the above referenced specifications. The unit complies with all essential requirements of the Directives.

Responsible Person: Neil Sawers
Position: Technical Manager
Signature:



Date: November 2018

15 HEALTH AND SAFETY INFORMATION

Under the Consumer Protection Act 1987 and Section 6 of the Health & Safety at Work Act 1974, we are required to provide information on substances hazardous to health (COSHH Regulations 1988).

Adhesives, sealants and paints used in the manufacture of the product are cured and present no known hazards when used in the manner for which they are intended.

The following other materials are present in the product:

15.1 INSULATION MATERIALS

Material Types:

Ceramic fibre board, mineral wool.

Description:

Rigid board, slabs, sleeves, gaskets, ropes.

Known Hazards:

May cause temporary irritation or rash to skin. High dust levels may irritate eyes and upper respiratory system.

Precautions:

Avoid unnecessary or rough handling, or harsh abrasion of boards. Normal handling and use of material should not produce high dust levels.

Avoid inhalation, and contact with skin and eyes.

After handling always follow normal good hygiene practices.

Protection:

Use disposable gloves, face mask and eye protection.

First Aid:

Eyes - If irritation occurs, wash eyes with copious amounts of water.

If symptoms persist, seek immediate medical advice.

Skin

If irritation occurs, wash under running water before washing with soap and water.

Inhalation

Remove to fresh air, drink water to clear throat and blow nose to remove dust/fibres.

Ingestion

Drink plenty of water.

15.2 SEALANT AND ADHESIVE

Material Types:

Silicone elastomer.

Description:

Sealant and adhesive.

Known Hazards:

Irritation to eyes.

Precautions:

Avoid inhalation of vapour, contact with eyes and prolonged or repeated contact with skin.

After handling always follow normal good hygiene practices.

Protection:

Use eye protection. Rubber or plastic gloves should be worn where repeated contact occurs and a face mask worn when working in confined spaces.

First Aid:

Eyes

Flush eyes with water for 15 minutes. Seek immediate medical attention.

Skin

Wipe off and wash with soap and water.

Inhalation

Remove to fresh air.

15.3 KEROSENE AND GAS OIL FUELS (MINERAL OILS)

Known Hazards:

The effect of mineral oils on the skin vary according to the duration of exposure and the type of oil.

The lighter fractions remove the protective grease naturally present on the skin, leaving it dry, liable to crack and more prone to damage by cuts, abrasions and irritant chemicals.

Skin rashes (Oil acne) most often on arms, but also on any part of the body in contact with oil or oily clothing.

Contact with fuel oils can cause dermatitis.

Precautions:

Avoid as far as possible any skin contact with mineral oil or with clothing contaminated with mineral oil.

The use of a lanolin-based barrier cream is recommended, in conjunction with regular washing with soap and rinsing with water to ensure all oil is removed from the skin.

Take care to prevent clothing, especially underwear, from becoming contaminated with oil.

Do not put oily rags or tools in pockets, especially trouser pockets.

Have first-aid treatment at once for an injury, however slight.

Do not inhale any vapours from mineral oils.

16 END OF LIFE INFORMATION

GENERAL

Grant oil boilers incorporate components manufactured from a variety of different materials. The majority of these materials can be recycled whilst the smaller remainder cannot.

Materials that cannot be recycled must be disposed of according to local regulations using appropriate waste collection and/or disposal services.

DISASSEMBLY

There is little risk to those involved in the disassembly of this product. Please refer to and follow the Health and Safety Information given in the Installation & Servicing Instructions provided with the boiler.

For guidance on the disassembly of the boiler refer to the information given in the Servicing section of the Installation & Servicing Instructions provided with the boiler.

RECYCLING

Many of the materials used in Grant oil boilers can be recycled, these are listed in the table below:

COMPONENT	MATERIAL
Outer casing panels	Mild steel (polyester powder coated)
Primary heat exchanger and baffles	Mild steel
Secondary heat exchanger	Stainless steel
Secondary heat exchanger spirals	Aluminium alloy
Pipework	Copper
Burner body/flange	Aluminium alloy
Burner oil pump	Aluminium alloy/steel
Riello oil burner cover	Plastic
Electrical wiring	Copper/plastic
Thermostats	Copper/plastic
Printed Circuit boards	Copper/plastic

DISPOSAL

All materials other than those listed above must be disposed of responsibly as general waste.



Neil Sawers
Technical Manager

17 PRODUCT FICHE

Product fiche concerning the
 COMMISSION DELEGATED REGULATIONS
 (EU) No 811/2013 of 18 February 2013
 (EU) No 813/2013 of 2 August 2013

Vortex Pro Combi	Symbols	Unit	Outdoor Combi 21	Outdoor Combi 26	Outdoor Combi 36
Condensing boiler			Yes	Yes	Yes
Low temperature boiler			No	No	No
B1 boiler			No	No	No
Combination heater			Yes	Yes	Yes
Rated heat output	Prated	kW	21	26	36
Useful heat output					
At rated heat output and high temperature regime	P_4	kW	21	26	36
At 30% of rated heat output and low temperature regime	P_1	kW	6.3	7.8	10.8
Auxiliary electricity consumption					
At full load	elmax	kW	0.158	0.13	0.15
At part load	elmin	kW	0.052	0.052	0.039
In standby mode	P_{SB}	kW	0.009	0.009	0.009
Declared load profile			XL	XL	XL
Daily electricity consumption	Q_{elec}		0.293	0.23	0.205
Annual electricity consumption	AEC		65.4	50.5	45.2
Useful efficiency					
Seasonal space heating energy efficiency	η_s	%	90.81	91.71	94.56
At rated heat output and high temperature regime	η_4	%	88.9	93.6	95.1
At 30% of rated heat output and low temperature regime	η_1	%	97.1	96.4	99.3
Other items					
Standby heat loss	P_{stby}	kW	0.23	0.264	0.522
Ignition burner power consumption	P_{ign}	kW	0	0	0
Annual energy consumption	Q_{HE}	kWh	-	-	-
Sound power level indoors	L_{WA}	dB	50	51	54
Emissions of nitrogen oxides	NO_x	mg / kWh	<120	<120	<120
Emission class			2	2	2
Water heating efficiency	η_{wh}	%	68.23	62.6	60.38
Daily fuel consumption	Q_{fuel}	kWh	27.2	30	31.1
Annual fuel consumption	AFC	GJ	21.556	26.673	24.67

18 GUARANTEE

You are now the proud owner of a Grant Vortex condensing boiler from Grant Engineering (UK) Limited which has been designed to give years of reliable, trouble free operation.

Grant Engineering (UK) Limited guarantees the manufacture of the boiler including all electrical and mechanical components for a period of **twelve months from the date of installation**⁴, provided that the boiler has been installed in full accordance with the installation and servicing instructions issued.

This will be extended to a total period of **two years** if the boiler is registered with Grant Engineering (UK) Limited within **thirty days of installation** and it is serviced at twelve month intervals³. See main Terms and Conditions below.

If the boiler is installed as part of a VortexAir (hybrid) installation, the guarantee for the boiler will start from its original date of installation and NOT from the date of installation of the heat pump (if installed on different dates).

Registering the product with Grant Engineering (UK) Limited

Please register your Grant Vortex condensing boiler with Grant Engineering UK Limited **within thirty days of installation**. To do so visit:

www.grantuk.com/support/product-registration

You can register your boiler for a further **twelve months** guarantee (giving **two years** from the date of installation⁴). This does not affect your statutory rights¹.

If a fault or defect occurs within the manufacturer's guarantee period

If your boiler should fail within the guarantee period, you must contact Grant Engineering (UK) Limited who will arrange for the repair under the terms of the guarantee, providing that the boiler has been correctly installed, commissioned and serviced (if the appliance has been installed for more than twelve months) by a competent person and the fault is not due to tampering, running out of oil, oil contamination, debris, system water contamination, misuse, trapped air or the failure of any external components not supplied by Grant Engineering (UK) Limited, e.g. fire valve, motorised valve, etc.

This two year guarantee only applies if the boiler is registered with Grant Engineering (UK) Limited within thirty days of installation⁴ and is serviced after twelve months³.

In the first instance

Contact your installer or commissioning engineer to ensure that the fault does not lie with the system components or any incorrect setting of the system controls that falls outside of the manufacturer's guarantee otherwise a service charge could result. Grant Engineering (UK) Limited will not be liable for any charges arising from this process.

If a fault covered by the manufacturer's guarantee is found

Ask your installer to contact Grant Engineering (UK) Limited Service Department on +44 (0)1380 736920 who will arrange for a competent service engineer to rectify the fault.

Remember - before you contact Grant Engineering (UK) Limited

- Ensure the boiler has been installed, commissioned and serviced by a competent person in accordance with the installation and servicing instructions.
- Ensure there is oil to supply the burner.
- Ensure the problem is not being caused by the heating system or its controls. Consult the boiler handbook for guidance.

Free of charge repairs

During the **two year** guarantee period no charge for parts or labour will be made provided that the boiler has been installed and commissioned correctly in accordance with the manufacturer's installation and servicing instructions, it was registered with Grant Engineering (UK) Limited within thirty days of installation⁴ and, for boilers over twelve months old, details of annual service is available³.

The following documents must be made available to Grant Engineering (UK) Limited on request:

- Proof of purchase
- CD10 Installation Completion Form (or equivalent document)
- CD11 Commissioning Report Form (or equivalent document)
- Service documents (CD11 or equivalent document)

Chargeable repairs

A charge may be made (if necessary following testing of parts) if the breakdown is due to any fault(s) caused by the plumbing or heating system, e.g. contamination of parts due to system contamination, sludge, scale, debris or trapped air. Refer to 'Extent of manufacturer's guarantee'.

Extent of manufacturer's guarantee

The manufacturer's guarantee does NOT cover the following:

- If the boiler has been installed for over **two years**.
- If the boiler has not been installed, commissioned, or serviced by a competent person in accordance with the installation and servicing instructions.
- Instances where the serial number has been removed or made illegible.
- Fault(s) due to accidental damage, tampering, unauthorised adjustment, neglect, misuse or operating the boiler contrary to the manufacturer's installation and servicing instructions.
- Damage due to external causes such as bad weather conditions (flood, storms, lightning, frost, snow, or ice), fire, explosion, accident or theft.
- Fault(s) due to incorrectly sized expansion vessel(s), incorrect vessel charge pressure or inadequate expansion on the system.
- Fault(s) caused by external electrics and external components not supplied by Grant Engineering (UK) Limited.
- Problems caused by lack of oil or faults with the oil storage and supply system.
- Fault(s) due to contamination of the oil storage and supply system, e.g. water or debris.
- Bleeding or removing oil storage tank contamination or blockages from oil lines.
- Problems due to the flue system being incorrectly fitted or not installed to meet installation requirements.
- Boiler servicing, de-scaling or flushing.
- Cleaning out condensate traps/discharge pipes or thawing out frozen condensate pipework.
- Checking and replenishing system pressure.
- Oil supply pipelines, electrical cables and plugs, external controls not supplied by Grant Engineering (UK) Limited.
- Heating system components, such as radiators, pipes, fittings, pumps and valves not supplied by Grant Engineering (UK) Limited.
- Instances where the oil boiler has been un-installed and re-installed in another location.
- Use of spare parts not authorised by Grant Engineering (UK) Limited.
- Consumable items including, but not limited to, oil nozzles, oil hoses, gaskets and seals.

IMPORTANT

The nozzle and braided oil hose supplied with the boiler are only covered for the period up to the time of the first service (twelve months). Both **must** be changed on the first service and on every annual service thereafter.

IMPORTANT

A suitable oil filter with a minimum 15µ filtration **must** be installed in the oil supply line.

Do not wait until the fuel supply runs out before you re-order. Sludge in the bottom of the tank may be drawn into the fuel lines. It is recommended that the boiler is switched off when the new oil supply is delivered and that the fuel is allowed to settle for an hour before restarting the boiler.

Terms of manufacturer's guarantee

- The Company shall mean Grant Engineering (UK) Limited.
- The boiler must be installed by a competent person and in full accordance with the relevant Codes of Practice, Regulations and Legislation in force at the time of installation.
- The boiler is guaranteed for **two years** from the date of installation⁴, providing that every twelve months the annual service has been completed³ and the boiler registered with the Company within thirty days of installation. Any work undertaken must be authorised by the Company and carried out by a competent service engineer.
- This guarantee will be invalid if the boiler does not have an annual (every twelve month) service and will then be limited to twelve months from the date of installation⁴.
- The shell (heat exchanger) of the oil boiler is covered by a **five year parts and labour** guarantee from the date of installation⁴. This is subject to the following:
 - The boiler is operated correctly, in accordance with the Installation and servicing instructions.
 - Grant Engineering (UK) Limited **strongly recommends** that a Grant Mag-One in-line magnetic filter/s (or equivalent⁵) is fitted in the heating system pipework. This should be installed and regularly serviced in accordance with the filter manufacturer's instructions. We reserve the right to ask for proof of installation – failure to provide this may result in the guarantee becoming invalid.
 - Proof is provided that the system has been flushed or chemically cleaned where appropriate (refer to BS 7593) and that the required quantity of a suitable corrosion inhibitor added.
 - Proof of annual servicing (including the checking of any expansion vessels and pressure relief valves) must be provided if and when requested by the Company.
- This guarantee does not cover breakdowns caused by incorrect installation, neglect, misuse, accident or failure to operate the boiler in accordance with the manufacturer's installation and servicing instructions.
- The boiler is registered with the Company within thirty days of installation. Failure to do so does not affect your statutory rights¹.
- The balance of the guarantee is transferable providing the installation is serviced prior to the dwelling's new owners taking up residence. Grant Engineering (UK) Limited must be informed of the new owner's details.
- The Company will endeavour to provide prompt service in the unlikely event of a problem occurring, but cannot be held responsible for any consequences of delay however caused.
- This guarantee applies to Grant Engineering (UK) Limited boilers purchased and installed on the UK mainland, Isle of Wight, Channel Islands, Isle of Man and Scottish Isles only². Provision of in-guarantee cover elsewhere in the UK is subject to agreement with the Company.
- All claims under this guarantee must be made to the Company prior to any work being undertaken. Invoices for call out/repair work by any third party will not be accepted unless previously authorised by the Company.
- Proof of purchase and date of installation, commissioning and service documents must be provided on request.
- If a replacement boiler is supplied under the guarantee (due to a manufacturing fault) the product guarantee continues

from the installation date of the original boiler and **not** from the installation date of the replacement⁴.

- The oil boiler must be connected to a mains water supply (installations utilising a private water supply are not covered by this guarantee).
- Breakdown/failure due to lime scale will not be covered by this guarantee.
- The replacement of a boiler under this guarantee does not include any consequential costs, such as the removal or replacement of worktops, kitchen units, etc.
- The boiler (excluding external modules) must not be sited in a location where it may be subjected to frost.

Hard water advice (for Combi boilers only)

If you live in a hard water area, protection against scaling must be given to the domestic hot water heat exchanger of your combination boiler.

You should fit an appropriate scale inhibitor or water softener as any breakdown caused by water scaling is not covered by the manufacturer's guarantee. Ask your installer for advice.

Foot notes

1. Your statutory rights entitle you to a one year guarantee period only.
2. The UK mainland consists of England, Scotland and Wales only. Please note that for the purposes of this definition, Northern Ireland and Scilly Isles are **not** considered part of the UK mainland.
3. We recommend that your oil boiler is serviced every twelve months (even when the guarantee has expired) to prolong the lifespan and ensure it is operating safely and efficiently.
4. The guarantee period will commence from the date of installation, unless the installation date is more than six months from the date of purchase, in which case the guarantee period will commence six months from the date of purchase.
5. As measured by gauss. The MagOne magnetic filter has a gauss measurement of 12,000.

Version 1.2 – February 2017

APPENDIX A1 WILO YONOS PARA RS RKC CIRCULATING PUMP

A1.1 WILO YONOS PARA RS RKC CIRCULATING PUMP

A1.1.1 PUMP SPECIFICATION

Table A1-1: Pump specification

Make and model	Wilco Yonos PARA RS 15/7.0 RKC FS 130 12
Construction	
Pump housing	Cast iron (with cataphorisis treatment)
Impellar	PP composite with GF 40%
Pump shaft	Stainless Steel
Bearing	Carbon, metal impregnated
Protection Class	IPx4D
Insulation Class	F
Motor Protection	Integrated
Performance	
Max. delivery head	7.2m @ Q = 0 m ³ /h
Max. volume flow	3.3 0 m ³ /h
Minimum suction head @ 50/95°C	0.5/4.5m
Power consumption @ 1 - 230V	3-45W
Nominal Motor Power	37W
Current @ 1 - 230V	0.028 - 0.44 A
Energy Efficiency Index (EEI)	≤ 0.20
Speed	800-4650 rpm
Settings	ΔP-variable (1-7m head) and Constant Speed (I, II and III)
Application	
Maximum Static Pressure	PN6
Temperature range @ maximum ambient temperatures	Maximum ambient temperature 57°C: 0 to 95°C
	Maximum ambient temperature 59°C: 0 to 90°C
	Maximum ambient temperature 67°C: 0 to 70°C
Approved Fluids	Heating Water Water/Glycol - Max 1:1 (above 20% check pumping data)

A1.1.2 PUMP CONTROL PANEL

Wilco Yonos PARA RKC circulating pumps have two possible setting modes:

- Constant speed with three pump speed settings (I, II and III)
- Variable pressure (Δp-v) with pump head adjustable between 1 and 7m head

Figure A1-1 shows the pump control panel with the red selector knob.

Constant Speed Mode (I, II, III)

This is the default setting of the pump and as such is recommended by Grant for heating systems. In this mode the pump speed is not automatically regulated (as with the Variable Pressure Mode), but operates constantly at one of the three possible speeds (set using the red selector knob on the pump control panel).

Variable Pressure Mode (Δp-v)

In this mode the electronic control changes the differential pressure setpoint to be maintained by the pump in a linear fashion between Hs (the value set using the red selector knob on the pump control panel) and ½ Hs. The differential setpoint varies linearly with the volume flow Q.

A1.1.3 INDICATOR LED

The pump is fitted with an indicator LED. This is located around the circumference of the red selector knob. See Figure A1-1 below. This indicates the operating status of the pump and will be illuminated green when the pump is operating normally. This indicator LED can assist in diagnosing and rectifying faults. Refer to Section A1.2.

A1.1.4 SETTING THE PUMP CONTROL MODE

Set the pump to one of the two operating modes as follows:

Constant Speed Mode (I, II, III)

Grant recommends this operating mode for the pump.

To set the pump to the 'Constant Speed' mode, the pointer on the red selector knob must be set to the RIGHT of the mid position. Refer to Figure A1-1.

Set it to point at the required speed setting, I, II or III as required, ensuring that there is adequate flow to distribute the heat from the boiler whilst avoiding high water velocities causing noise in the pipework.

Variable Pressure Mode (Δp-v)

To set the pump to the 'Variable Pressure' mode the pointer on the red selector knob must be set to the LEFT of the mid position. Refer to Figure A1-1.

The further anticlockwise it is set the greater the pressure head setting of the pump – from 1m to 7m head.

If this mode is to be used, set the selector knob at a pressure that represents the maximum pressure (head) loss for the heating system in question.

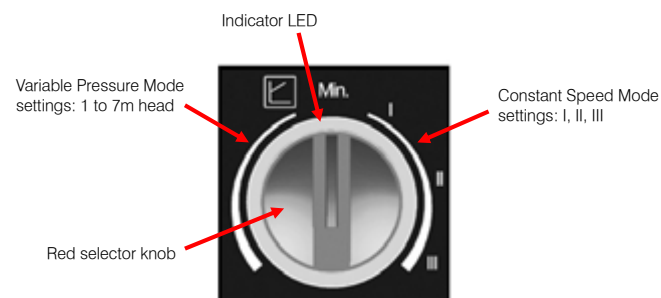

Figure A1-1: Pump control panel with red selector knob and LED indicator

! NOTE !

Both circulating pumps on all Grant Vortex Combi boilers come factory set at Constant Speed Mode III and should be left set on this setting.

The heating circuit circulating pump should be set by the installer to suit the system.

A1.2 CIRCULATING PUMP FAULT DIAGNOSIS - WILO YONOS PARA RS RKC

The indicator LED, located around the circumference of the red control knob can assist in diagnosing and rectifying a fault with the pump. See the table below:

Table A1-2: Pump fault diagnosis

LED condition	Meaning	Diagnostic	Cause	Remedy
Green	Pump operating	Pump runs according to the red knob setting	Normal operation	N/A
Flashes red and green	Pump is operating but stopped	Pump restarts itself after fault has disappeared	Undervoltage Voltage <160V OR Overvoltage Voltage >253V	Check supply voltage is 195V<V<253V
			Overheating: temperature inside motor too high	Check water and ambient temperature
Flashes red	Pump not operating	Pump stopped (blocked)	Pump does not restart itself due to a permanent failure	Replace pump
LED off	No power supply	No voltage to pump control electronics	Pump is not connected to power supply	Check cable connection
			LED is damaged	Check if pump is running
			Electronics are damaged	Replace pump

APPENDIX A2 WILO-PARA 25-130/7-50/SC-6#GRA CIRCULATING PUMP

A2.1 WILO-PARA 25-130/7-50/SC-6#GRA CIRCULATING PUMP

A2.1.1 PUMP SPECIFICATION

Table A2-1: Pump specification

Make and model	Wilo - PARA 25-130/7- 50/SC-6#GRA
Construction	
Pump housing	Cast iron (with cataphoresis treatment)
Impellar	PP composite with GF 40%
Pump shaft	Stainless Steel
Bearing	Carbon, metal impregnated
Motor Data	
Speed	2580 - 4700rpm
Power consumption @ 1 - 230V	8.2 - 50W
Current @ 1 - 230V	0.07 - 0.43A
Minimum starting voltage	170V
Minimum running voltage	160V
Peak inrush current	>3A
Starting torque	>25N.cm
Electrical	
Mains connection	1ph 230V AC +10%/-15% 50/60Hz
Protection Class	IPx4D
Insulation Class	F
Motor Protection	Integrated
Performance	
Max. delivery head	7.7m @ Q = 0 m ³ /h
Max. volume flow	3.5 m ³ /h
Minimum suction head @ 50/95°C	0.5/4.5m
Energy Efficiency Index (EEI)	≤ 0.20
Settings	ΔP-variable (1-7m head) ΔP-constant (1-7m head) Constant Speed (I, II and III)
Application	
Maximum Static Pressure	PN10
Fluid Temperature range @ maximum ambient temperatures (See Section A2.1.2)	Maximum ambient temperature 58°C: 0 to 100°C Maximum ambient temperature 62°C: 0 to 90°C Maximum ambient temperature 66°C: 0 to 80°C Maximum ambient temperature 71°C: 0 to 70°C
Approved Fluids	Heating Water Water/Glycol - Max 1:1 (above 20% check pumping data)

A2.1.2 THERMAL PROTECTION FUNCTION

The pump is equipped with a thermal self-protection mode.

If the fluid temperature exceeds the maximum value at a specific ambient temperature, e.g. 90°C at an ambient of 62°C, the pump will automatically reduce the power consumption, reducing the speed and performance of the pump.

In this condition the Run/Fault signal LED will be blinking RED. When normal temperature conditions return the pump will automatically revert to normal operation.

If the fluid temperature increases further, the thermal protection function may stop the pump temporarily.

In this condition the Run/Fault signal LED on the pump will be constant RED until normal temperature conditions return.

A2.1.3 PUMP COMPONENTS

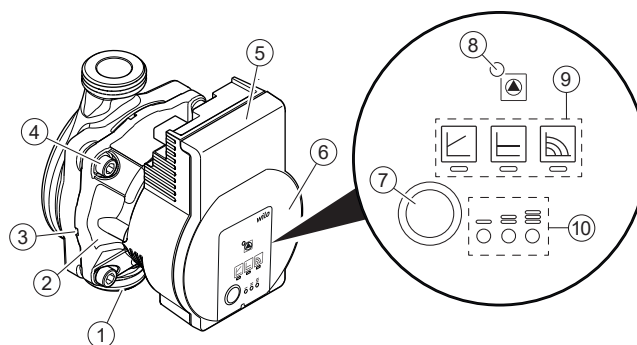

Figure A2-1: Pump components and control panel

1. Pump housing	6. Rating plate
2. Glandless motor	7. Operating button for pump adjustment
3. Condensate drain openings (4 around motor)	8. Run/Fault signal LED
4. Housing screws	9. Display of selected control mode
5. Control module	10. Display of selected pump curve (I, II, III)

A2.1.4 CONTROL PANEL

Indicator LEDs

- Run/Fault signal LED (item 8, Figure A2-1)
 - LED is GREEN when pump is running in normal pump operation.
 - LED lights up RED/flashes when there is a fault (refer to Section A2.2).
- Control mode display LEDs (item 9, Figure A2-1)
- Pump curve display LEDs (item 10, Figure A2-1)
- LED combinations are used to indicate when the following functions are in operation:
 - Pump venting (refer to Sections A2.1.5 and A2.1.6 for information on how to activate this function).
 - Manual restart (refer to Sections A2.1.5 and A2.2 for information on how to activate this function).
 - Key lock (refer to Sections A2.1.5 and A2.1.6 for information on how to activate this function).

Operating button - Green (item 7, Figure A2-1)

- Press to select:
 - Control mode
 - Pump curve (within the control mode)
- Press and hold to:
 - Activate the pump venting function (press for 3 seconds)
 - Activate manual restart (press for 5 seconds)
 - Lock/unlock control mode and pump curve (press for 8 seconds)

A2.1.5 OPERATING MODES

Wilo-Para 25-130/7-50/SC-6#GRA circulating pumps have three possible operating modes:

- Variable differential pressure ($\Delta p-v$) with three pre-defined pump curves (I, II and III)
- Constant differential pressure ($\Delta p-c$) with three pre-defined pump curves (I, II and III)
- Constant speed with three pump speed settings (I, II and III)

Variable Differential Pressure Mode ($\Delta p-v$)

Recommended for two-pipe heating systems with radiators to reduce the flow noise at thermostatic valves.

In this mode the electronic control reduces the delivery head of the pump to half in the case of decreasing volume flow in the pipework. There are three pre-defined pump curves (I, II and III) to choose from.

Constant Differential Pressure Mode ($\Delta p-c$)

Recommended for underfloor heating systems.

In this mode the electronic control maintains the set delivery head irrespective of the volume flow from the pump. There are three pre-defined pump curves (I, II and III) to choose from.

Constant Speed Mode

Recommended for systems with fixed system resistance requiring a constant volume flow from the pump.

This is the default setting of the pump and as such is recommended by Grant for heating systems.

In this mode the pump speed is not automatically regulated (as with the Variable or Constant differential pressure modes) but operates constantly at one of the three available speeds (I, II or III)

! NOTE !

Factory default setting is Constant speed mode - pump curve III.

Pump Venting Function

Activated by pressing and holding the green operating button for 3 seconds.

Automatically vents the pump. **This function DOES NOT vent air from the heating system.**

Manual Restart (Unblocking) Function

Activated by pressing and holding the green operating button for 5 seconds.

Unblocks the pump when required, e.g. after a long idle period in the summer.

Key Lock Function

Activated by pressing and holding the green operating button for 8 seconds.

Locks/unlocks the current pump settings set by the operating button, preventing unwanted adjustment of the current pump settings.

Factory Setting Function

Activated by pressing and holding the green operating button whilst switching the pump off, and continuing to hold the button down until all lights on the pump control panel are off.

When the pump is switched back on, it will operate at the original factory settings.

Factory default setting is Constant speed mode - pump curve III.

A2.1.6 COMMISSIONING

After installation of the boiler, commission the pump by using the following procedure:

Venting:

- Fill and vent system correctly. (Refer to Section 7)
- If the pump does not vent automatically use the pump vent function.
- Press and hold the green operating button for 3 seconds and release to start.
- The pump venting function will operate for 10 minutes, during which the pump alternated between off and on to vent air from the pump.
- Pump mode and pump curve LED rows flash in turn at 1 second intervals to indicate when this function is operating.
- To cancel, press and hold green operating button for 3 seconds.
- After 10 minutes the pump automatically reverts to the previously set operating mode, e.g. constant speed -curve III.

! NOTE !

After venting the LED display shows the previous pump settings.

Set Control Mode

- Switch on power to the pump.
- The factory setting is Constant speed mode - pump curve III.
- This will be indicated by the control mode LED and pump curve LED.
- Press the green operating button briefly (approx. 1 second) to change the pump setting.
- Continue to repeat pressing the button, using the following sequence, until the required pump mode and pump curve are set:

Table A2-2: Setting pump control mode

	LED display	Control mode	Pump curve
1		Constant speed	II
2		Constant speed	I
3		Variable differential pressure $\Delta p-v$	III
4		Variable differential pressure $\Delta p-v$	II
5		Variable differential pressure $\Delta p-v$	I
6		Constant differential pressure $\Delta p-c$	III
7		Constant differential pressure $\Delta p-c$	II
8		Constant differential pressure $\Delta p-c$	I
9		Constant speed	III

- Pressing the button for the 9th time returns to the basic setting (constant speed / characteristic curve III).

! NOTE !

Both circulating pumps on all Grant Vortex Combi boilers come factory set at Constant Speed Mode - Pump Curve III and should be left set on this setting.

The heating circuit circulating pump should be set by the installer to suit the system.

Lock Operating Button

- To activate the key lock function press and hold the green operating button for 8 seconds until the LEDs for the selected pump settings briefly flash, then release.
- LEDs flash constantly at 1 second intervals to show that key lock is activated.
- The pump settings can no longer be changed unless the key lock function is deactivated.
- To deactivate the key lock function press and hold the green operating button for 8 seconds, as above.

! NOTE !

All settings and displays are retained if the power supply is interrupted.

A2.2 CIRCULATING PUMP FAULT DIAGNOSIS - WILO-PARA 25-130/7-50/SC-6#GRA

The Run/Fault signal LED (item 8, Figure A2-1) will indicate if there is a fault with the pump and can assist in diagnosing and rectifying that fault as detailed in Table A2-3 below:

Table A2-3: Pump fault diagnosis

Run/Fault LED condition	Diagnostic	Cause	Remedy
Green	Normal Operation	Pump runs according to the pump settings	N/A
Red	Pump is stopped	Pump rotor blocked	Activate pump manual restart function
	Winding	Winding defective	
Flashes red	Under/Over voltage	Undervoltage: Voltage < 160V OR Overvoltage: Voltage > 253V	Check mains voltage and operating conditions (water and ambient temperature)
	Excessive motor temperature	Overheating: Temperature inside motor too high	
	Short circuit	Motor current too high	
Flashes red/green	Pump stopped (blocked)	Water flowing through pump but no mains voltage to motor	Check mains voltage, water quantity and pressure and ambient conditions.
	Dry running	Air in pump	
	Overload	Sluggish motor with slower speed than normal operation. Pump is operating outside temperature limits.	
LED off	No power to pump control electrics	Pump is not connected to power supply	Check cable connection
		LED is damaged	Check if pump is running
		Electronics are damaged	Replace pump

Manual Restart (Unblocking) Function:

The pump will attempt an automatic restart if a blockage is detected. If this is not successful, the Run/Fault LED will be constant RED.

To activate the manual restart (unblocking) function:

- Press and hold the green operating button for 5 seconds to activate the manual restart function.
- The restart function will run for up to 10 minutes.
- The pump automatically alternates between forward and reverse operation to unblock the pump.
- Pump mode and pump curve LEDs flash in succession in a clockwise direction to indicate when this function is operating.
- To cancel, press and hold the green operating button for 5 seconds.

NOTES



GRANT ENGINEERING (UK) LIMITED

Hopton House, Hopton Industrial Estate, Devizes, Wiltshire, SN10 2EU
Tel: +44 (0)1380 736920 Fax: +44 (0)1380 736991
Email: info@grantuk.com www.grantuk.com