

# Grant Aeron<sup>3</sup>

## Air to Water High Efficiency Heat Pump Range

### Installation and Servicing Instructions

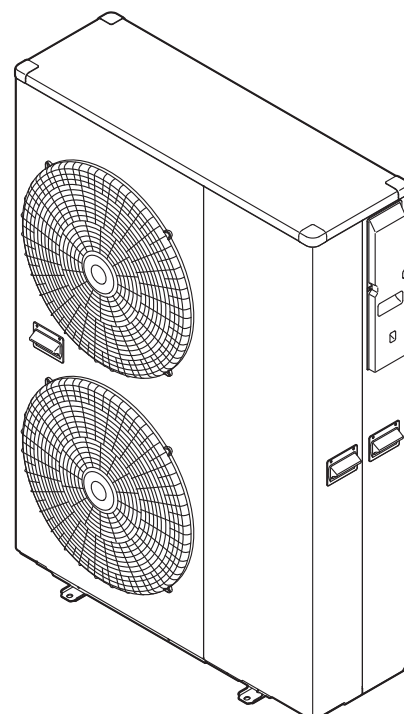
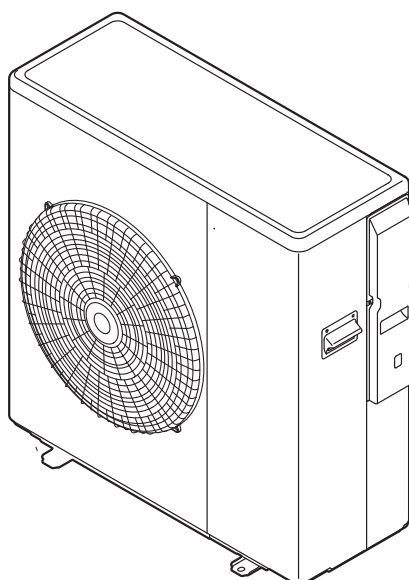
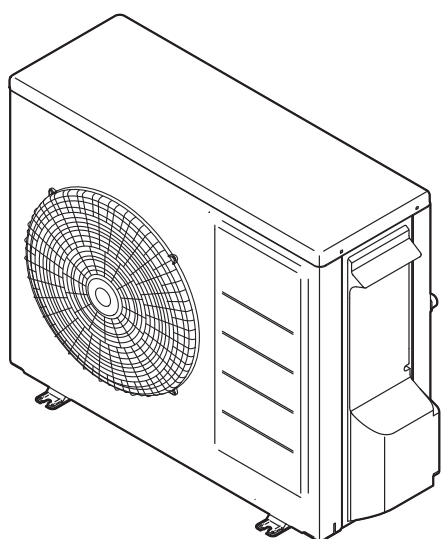

## IMPORTANT NOTE FOR INSTALLERS

These instructions are intended to guide installers on the installation, commissioning and servicing of the Grant Aeron<sup>3</sup> heat pump. After installing the heat pump, leave these instructions with the user.

A user handbook is available to guide users in the operation of the heat pump.

## SPECIAL TEXT FORMATS

The following special text formats are used in these instructions for the purposes listed below:



WARNING

**Warning of possible human injury as a consequence of not following the instructions in the warning.**



CAUTION

**Caution concerning likely damage to equipment or tools as a consequence of not following the instructions in the caution.**



NOTE

**Used for emphasis or information not directly concerned with the surrounding text but of importance to the reader.**

## PRODUCT CODES COVERED

These instructions cover the following product codes:

Product code
HPID6 - 6kW
HPID10 - 10kW
HPID16- 16kW
Output at 7°C air and 35°C flow temperature

## SERVICING

The heat pump should be serviced at least every twelve months and the details entered in the Service Log in the user handbook.



### GRANT ENGINEERING (IRELAND) ULC

Crinkle, Birr, Co Offaly  
R42 D788, Ireland  
www.grantengineering.ie  
Email: info@grantengineering.ie  
Tel: +353 (0)57 91 20089 Fax: +353 (0)57 91 21060

This manual is accurate at the date of printing but will be superseded and should be disregarded if specifications and/or appearances are changed in the interests of continued product improvement. However, no responsibility of any kind for any injury, death, loss, damage or delay however caused resulting from the use of this manual can be accepted by Grant Engineering (Ireland) ULC, the author or others involved in its publication.

All goods sold are subject to our official Conditions of Sale, a copy of which may be obtained on application.

© Grant Engineering (Ireland) ULC No part of this manual may be reproduced by any means without prior written consent.

# CONTENTS

<b>1</b>	<b>Introduction</b>	<b>4</b>	<b>9</b>	<b>Commissioning</b>	<b>48</b>
1.1	General	4	9.1	System Setup	48
1.2	Main Components	4	9.2	Setting the Day and Time	48
1.3	Planning Permission	4	9.3	Access for Parameter Settings	49
1.4	DNO Application	4	9.4	Accessing the Parameter Setting Menu (User level)	49
1.5	Important Advice	4	9.5	Accessing the Parameter Setting Menu (Installer level)	49
1.6	Product Contents	4	9.6	Temperature Control - DHW function	49
1.7	Installation Accessories	4	9.7	Parameters Input/Output	50
1.8	Control Parameters	4	9.8	Remote Controller Back Light Display Parameters	50
1.9	Heat Pump Components	5	9.9	Weather Compensation	51
<b>2</b>	<b>Technical Data</b>	<b>6</b>	9.10	Frost Protection Function Setting	51
2.1	Heat Pump Technical Data	6	9.11	Pump Operation and Air Bleeding from Heating System	51
2.2	Main Supply Cable	6	9.12	Pump Output Setting	51
2.3	Base Tray Heater	6	9.13	Coastal Installations	51
2.4	Heat Pump Dimensions	7	<b>10</b>	<b>Servicing</b>	<b>52</b>
2.5	Remote Controller Dimensions	8	10.1	General	52
<b>3</b>	<b>Installation Information</b>	<b>9</b>	10.2	Air Inlet and Outlet	52
3.1	Introduction	9	10.3	Condensate Disposal	52
3.2	Heating System Design Criteria	9	10.4	Heating System Connections	52
3.3	Regulations	10	10.5	Heat Pump Controls	52
3.4	Heat Pump Location	10	10.6	Refrigerant	52
3.5	Preparation for Installation	10	10.7	Monitor Display Function	53
3.6	Installing the Heat Pump	11	<b>11</b>	<b>Fault Finding</b>	<b>54</b>
3.7	Metering for Domestic RHI Installations	12	11.1	Error Code Display	54
3.8	Volumiser Tanks	12	11.2	Error History Display	54
3.9	Hot Water Cylinders	12	11.3	Reset Error Code Display	54
3.10	Hydraulic Diagram	13	11.4	Error Codes	55
3.11	Before you Commission	14	11.5	Table of Controller PCB and Terminal PCB Alarms	58
3.12	Completion	15	11.6	Error Codes and PCB Alarm Figures and Tables	59
3.13	Installation Checklist	15	<b>12</b>	<b>Spare Parts</b>	<b>62</b>
<b>4</b>	<b>Sealed Systems</b>	<b>18</b>	12.1	Exploded Diagram - HPID6	62
4.1	Sealed System Requirements	18	12.2	Spare Parts List - HPID6	63
4.2	Filling the Sealed System	19	12.3	Exploded Diagram - HPID10	64
4.3	Pressure Relief (Safety) Valve Operation	19	12.4	Spare Parts List - HPID10	65
<b>5</b>	<b>Domestic Hot Water</b>	<b>20</b>	12.5	Exploded Diagram - HPID16	66
5.1	Temperature Control	20	12.6	Spare Parts List - HPID16	67
5.2	Heat Pump Cylinders	20	<b>13</b>	<b>Declaration of Conformity</b>	<b>68</b>
5.3	Legionella	21	<b>14</b>	<b>Health and Safety Information</b>	<b>69</b>
5.4	Automatic DHW Boost Kit	21	14.1	General	69
<b>6</b>	<b>Electrical</b>	<b>24</b>	14.2	Refrigerant (410A)	69
6.1	Main PCP	24	<b>15</b>	<b>Disposal and Recycling</b>	<b>69</b>
6.2	Terminal PCB Input/Output	25	<b>16</b>	<b>Product Fiches</b>	<b>70</b>
6.3	Power Supply	25	<b>17</b>	<b>Guarantee</b>	<b>76</b>
6.4	Wiring first fix Options	26	<b>Appendix A - Parameters List</b>	<b>78</b>	
6.5	Tightening Torques	27	<b>Appendix B - Wiring Diagrams</b>	<b>80</b>	
6.6	Solar Thermal	27	<b>Appendix C - Parameters Record</b>	<b>82</b>	
6.7	System Control Wiring Diagrams	28			
<b>7</b>	<b>Remote Controller</b>	<b>32</b>			
7.1	Remote Controller	32			
7.2	Installation Requirements	32			
7.3	Installing the Remote Controller	32			
7.4	Connecting the Remote Controller to the Heat Pump	33			
7.5	Buttons	34			
7.6	Display Panel	35			
<b>8</b>	<b>Operation</b>	<b>36</b>			
8.1	Heat Pump Operation	36			
8.2	Weather Compensation	38			
8.3	Water Pump Management	39			
8.4	Frost Protection	42			
8.5	ON/OFF DHW Production Remote Contact	44			
8.6	ON/OFF Heating Remote Contact	45			
8.7	Night Mode	46			
8.8	Low Tariff	47			

# 1 INTRODUCTION

## 1.1 General

The Grant Aerona<sup>3</sup> range consists of three compact, lightweight, MCS approved, monobloc, air-to-water, inverter driven, single-phase air source heat pumps working with R410A refrigerant.

It is important that these installation and servicing instructions are followed to ensure correct installation and operation. Failure to do so may result in poor performance.

It is not within the scope of this manual to design the heating system or provide any advice regarding the layout of the system or any of the controls required for any individual heating system.

These instructions do not replace the installation or users manuals for any additional components used in the design of your system e.g. cylinders, motorised valves, programmers, solar thermal devices, buffers, etc.

**These instructions must be left with the product for future reference.**

## 1.2 Main Components

Each model incorporates the following main components:

- **DC inverter** - this responds rapidly to changing conditions to provide the necessary output to meet heating demands by varying the speed and output of the compressor, fan and circulating pump. This reduces the on/off times of the compressor, keeping the water temperature constant during operation reducing the electricity consumption.
- **Compressor** - a high-efficiency DC twin-rotary compressor to provide smooth performance and quiet operation.
- **Plate heat exchanger (condenser)** - the high-efficiency plate heat exchanger is used to transfer heat to the heating system primary circuit.
- **Fan** - a high-efficiency DC fan motor is used for smooth and quiet operation. A single fan is fitted to the 6kW (5 blade) and 10kW (3 blade) units. Two fans (3 blade) are fitted to the 16kW unit.
- **Circulating pump** - high-efficiency DC pump speed controlled from the ASHP control PCB.
- **Base tray heater** - factory fitted electric heater prevents condensate in the base of the heat pump from freezing. When the ambient temperature reaches 2.5°C, the base tray heater turns on and at 5.5°C turns off (ΔT of 3k). This cannot be adjusted or turned off. Refer to Section 2.3.
- **Pressure relief valve** - a 3 bar pressure relief valve is factory fitted.
- **Air purge valve (automatic air vent)** - factory fitted to assist in the removal of air from the heating primary circuit of the heat pump.

## 1.3 Planning Permission

The installation of a Grant Aerona<sup>3</sup> heat pump on domestic premises may be considered to be permitted development, not needing an application for planning permission, provided ALL the limits and conditions listed on the Planning Portal website are met.

For further information, visit [www.planningportal.gov/IRL](http://www.planningportal.gov/IRL).

## 1.4 DNO Application

An application must be made to the Distribution Network Operator (DNO) before connecting the heat pump(s) to the mains electrical supply. There are six DNOs operating the electrical distribution network throughout England, Scotland and Wales and the application must be made to the DNO covering the area concerned.

The necessary information required to make this application (J-forms) can be downloaded from the Grant IRL website ([www.grantirl.com](http://www.grantirl.com)), completed and then submitted to the correct DNO for the area in question.

## 1.5 Important Advice

1. It is essential that the full layout of the system is understood before the installation of any component is undertaken. If you are in any doubt,

please stop and seek advice from a qualified heating engineer or from Grant IRL. Please note that Grant IRL will not be able to offer specific advice about your system unless we designed it. In this case, we will always refer you to seek the advice of a qualified system designer.

2. The heat pump must be installed and commissioned in accordance with these installation and servicing instructions. Deviations of any kind will invalidate the guarantee and may cause an unsafe situation to occur. Please seek advice from Grant IRL if any of these user, installation and servicing instructions cannot be followed for whatever reason.
3. The heat pump contains high pressures and high temperatures during normal working conditions. Care must be taken when accessing the internal workings of the heat pump.
4. The heat pump contains an electrically driven fan which rotates at high speed. Disconnect the heat pump from the electrical supply before removing the top cover.

## 1.6 Product Contents

The Aerona<sup>3</sup> comes supplied on a single pallet. The following items are included:

	HPID6	HPID10	HPID16
Aerona <sup>3</sup> heat pump 6kW	1		
Aerona <sup>3</sup> heat pump 10kW		1	
Aerona <sup>3</sup> heat pump 16kW			1
Condensate drain elbow	1	1	1
Anti-vibration shoes	4		
¾ BSP x 22 mm flexible hose c/w washer	2		
1 BSP x 22 mm flexible hose c/w washer		2	2
1 nipple			2
1 x 1¼ reducing socket			2
22 mm isolating valve	2		
28 mm isolating valve		2	2
Remote controller	1	1	1
Remote controller cable (length: 8 metres)	1	1	1
Grant EP002 interface relay box	1	1	1
Installation and servicing instructions	1	1	1
User instructions	1	1	1

## 1.7 Installation Accessories

The following are available from Grant IRL:

Product code	Description
HPIDFOOT/KIT2	Anti-vibration mounts (2 x 600mm and fixing kit)
HPIDINSU/KIT	Through wall insulation kit (22 - 28mm flexible hoses)

## 1.8 Control Parameters

All parameters are listed sequentially in Appendix A.

## 1.9 Heat Pump Components

Air inlet is located in the left and rear of the unit

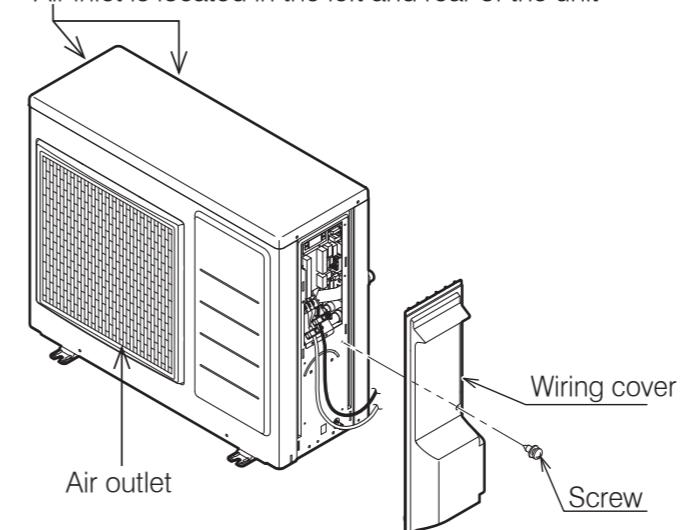

Figure 1-1: Main components (external) - 6kW

Air inlet is located in the left and rear of the unit

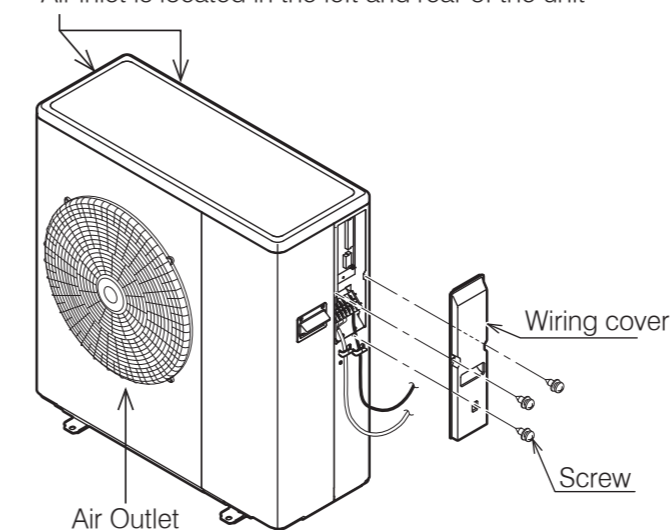

Figure 1-2: Main components (external) - 10kW

Air inlet is located in the left and rear of the unit

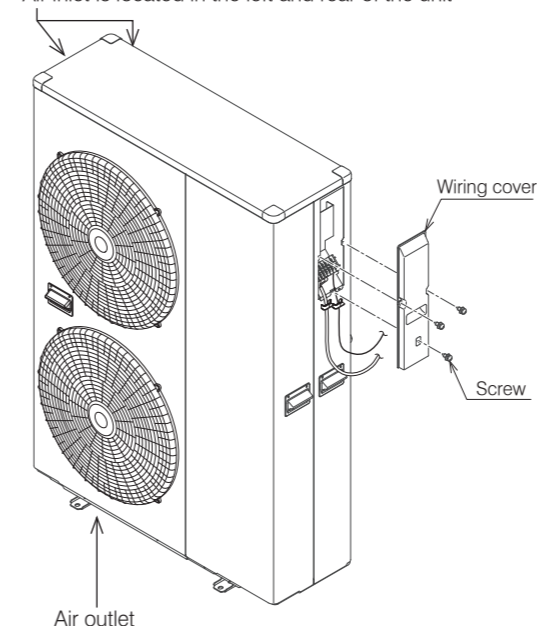

Figure 1-3: Main components (external) - 16kW

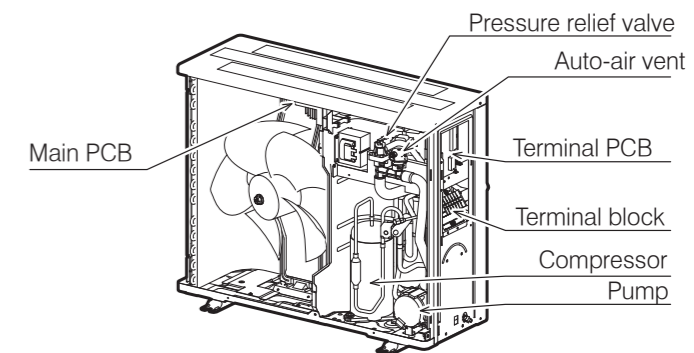

Figure 1-4: Main components (internal) - 6kW

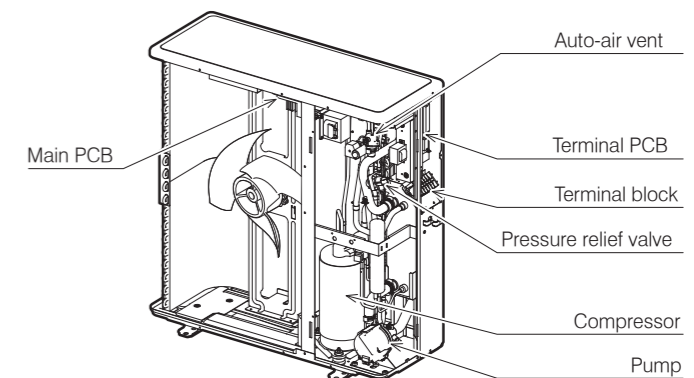

Figure 1-5: Main components (internal) - 10kW

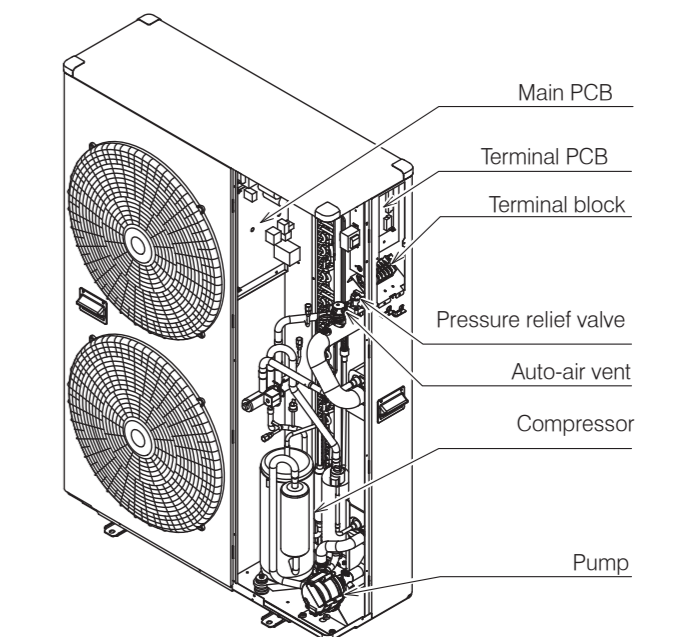

Figure 1-6: Main components (internal) - 16kW

# 2 TECHNICAL DATA

## 2.1 Heat Pump Technical Data

**Table 2-1:** Technical data

Model	Unit	HPID6	HPID10	HPID16
Heating capacity (BS EN 14511 - air: 7°C / water: 35°C)	kW	6.0	10.0	16.0
COP (BS EN 14511 - air: 7°C / water: 35°C)		4.11	4.35	4.10
SCOP (average climate conditions) - 35°C		4.34	4.35	4.19
Heating capacity (BS EN 14511 - air: 7°C / water: 55°C)	kW	5.38	9.0	13.3
COP (BS EN 14511 - air: 7°C / water: 55°C)		2.59	2.71	2.67
SCOP - average climate conditions (BS EN 14825 - water: 55°C)		3.15	3.15	3.15
Power supply		~230V 1ph 50Hz		
Power input (BS EN 14511 - air: 7°C / water: 35°C)	kW	1.46	2.30	3.90
Mechanical protection		IPX4		
Compressor		DC twin rotary - inverter driven		
Pressure (maximum)	MPa	4.1		
Refrigerant		R410A		
Mass of R410A	kg	1.05	1.72	2.99
Circulating pump	m head	10	6	12
Flow rate (minimum)	litres/min	5	10	15
Outdoor temperature	°C	-20 to 43		
Inlet water temperature	°C	5 to 55		
Water pressure (system)	MPa (bar)	0.1 to 0.3 (1 to 3 bar)		
Sound power level - internal (BS EN ISO 3743-1 - air: 7°C / water: 55°C)	dB(A)	42	46	42
Sound power level - external (BS EN ISO 3743-1 - air: 7°C / water: 55°C)	dB(A)	63	67	63
Sound pressure level at 5 metres - external (air: 7°C / water: 55°C)	dB(A)	44.1	47	44.1
Water connections	BSPF	¾"	1"	1¼"
Weight (empty)	kg	53	75	121
Weight (full)	kg	54	76.8	123
Water content	litres	1.0	1.8	2.0
Heat pump casing volume	m³	0.19	0.27	0.48
ErP rating (low temperature: 35°C flow) - heating		A++		
ErP rating (low temperature: 55°C flow) - heating				

## 2.2 Mains Supply Cable

**Always assume maximum possible load when considering cable sizing.**

The cable supplying power from the consumer unit to the heat pump must be connected via an external 2 pole isolator. This allows the service engineer to isolate the power supply before working on the heat pump safely.

Refer to Section 6 for connection details.

**Table 2-2:** Electrical installation requirements

Heat pump model	Maximum running current (A)	RCBO
		Rating (A)
HPID6	11.2	16
HPID10	17.5	20
HPID16	25.3	32

## 2.3 Base Tray Heater

The factory fitted electric heater prevents condensate in the base of the heat pump from freezing. When the ambient temperature reaches 2.5°C, the base tray heater turns on and at 5.5°C turns off (ΔT of 3k). This cannot be adjusted or turned off.

Base tray heater specification	
V	230V
P	185W
t	110°C
A	0.8A
Resistive load	
R	290 Ω

## 2.4 Heat Pump Dimensions

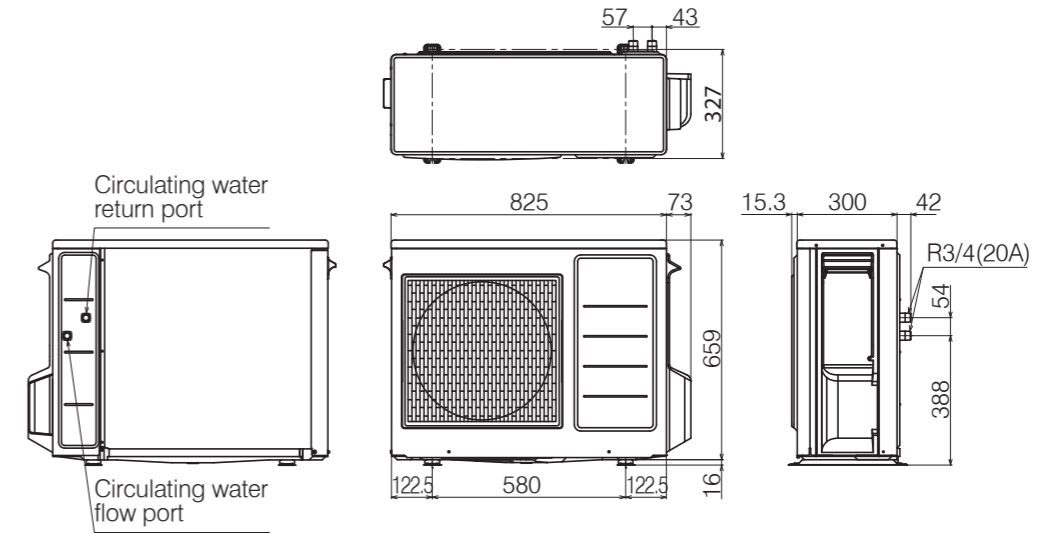

**Figure 2-3:** HPID6 dimensions

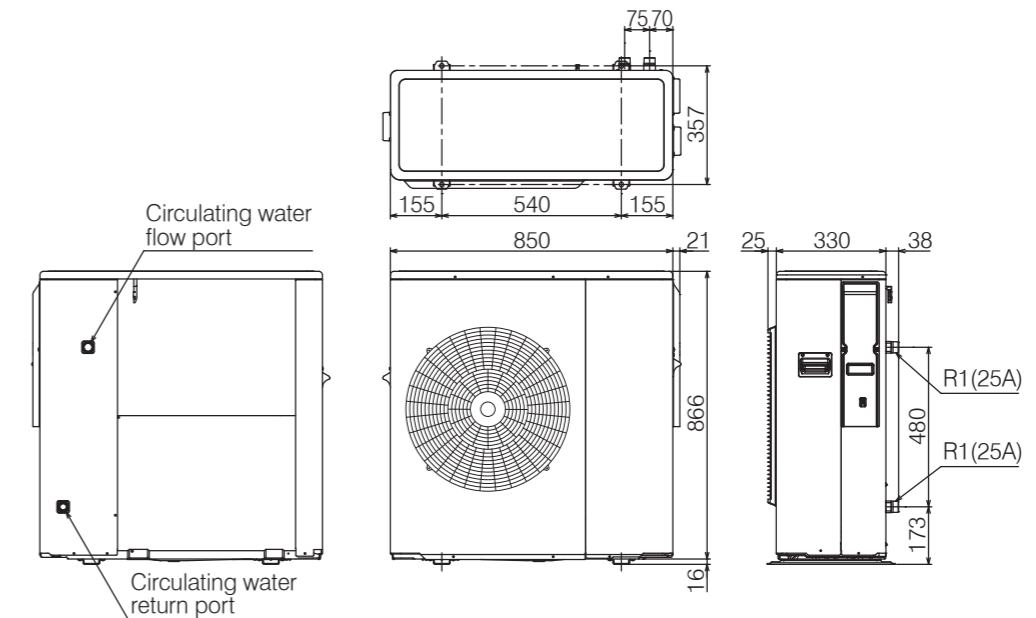

**Figure 2-4:** HPID10 dimensions

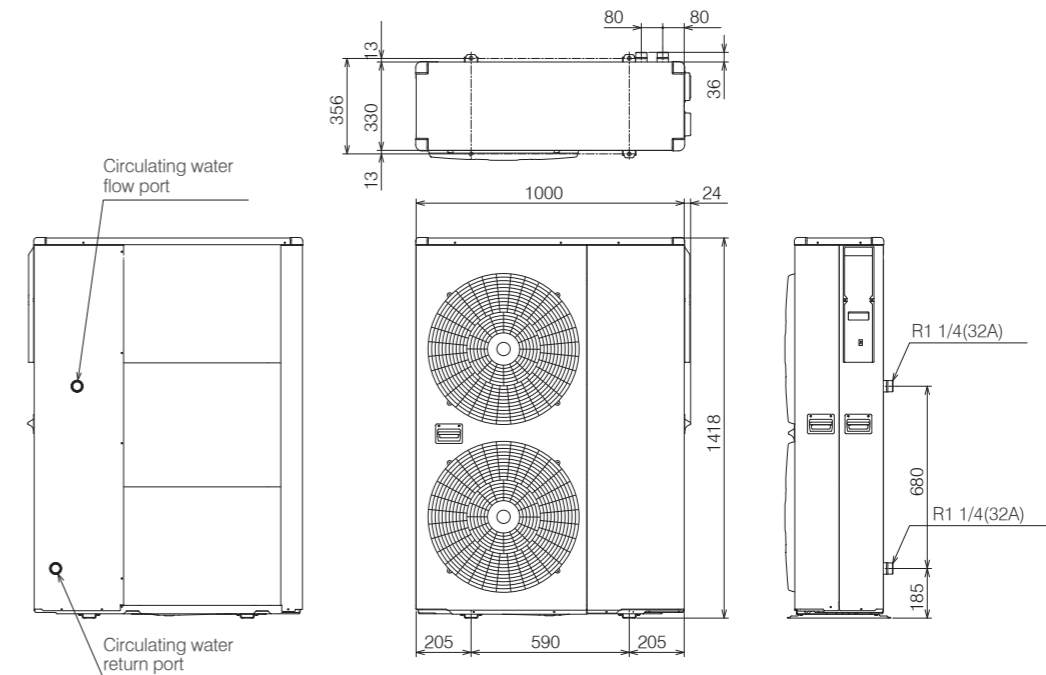

**Figure 2-5:** HPID16 dimensions

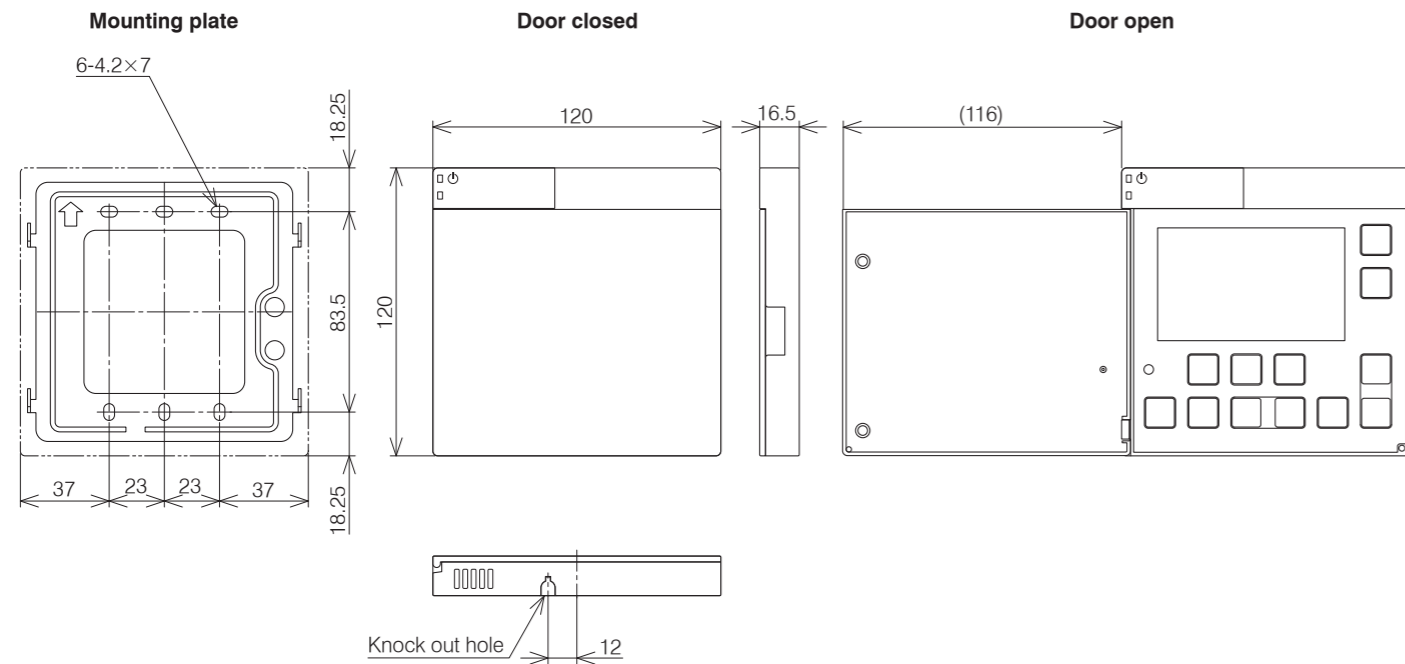

Figure 2-6: Remote controller dimensions

## 3 INSTALLATION INFORMATION

### 3.1 Introduction



NOTE

**Grant Aeron<sup>3</sup> heat pumps should be stored and transported in an upright position. If not, then the heat pump MUST be positioned in an upright position for at least four hours before being operated.**

For the heat pump to operate satisfactorily, install it as outlined in this installation manual.

- The Grant Aeron<sup>3</sup> heat pump should only be installed by a competent person.
- Before installing the heat pump, please read the following installation information carefully and install the heat pump as instructed.
- Be sure to follow the safety notices given.
- After completing the installation, check the product operates correctly. Then, explain to the user about the operation and maintenance requirements as shown in this manual.
- Be sure to install the heat pump in a suitable location that can support the heat pump when filled. Installation in an unsuitable location may cause injury to persons and damage to the heat pump.
- Do not install in a position where there is any possibility of flammable gas leakage such as from LPG cylinder around the heat pump. Leaked flammable gas around the heat pump may cause a fire.
- If the leaked refrigerant is exposed to fire, poisonous gas may be produced.
- Connect the heat pump with the flexible hoses and valves supplied, as described in this installation manual.
- Do not use an extension cable.
- Do not turn on the power until all installation work is complete.
- Only use correct Grant IRL parts and accessories to avoid accidents such as electric shock, fire and leakage of water.
- Never touch electrical components immediately after the power supply has been turned off as electrical shock may occur. After turning off the power, always wait five or more minutes before touching electrical components.
- Be sure to connect the power supply cable correctly to the terminal block as overheating can cause a fire.
- Ensure the wiring lid is fitted following installation to avoid electric shock at the terminal block.
- Always connect the earth wire to the heat pump.
- Install a correctly rated circuit breaker.
- After installation, the heat pump and heating system must be commissioned. Hand over all documentation to the end-user and explain the operating functions and maintenance according to these instructions.

### 3.2 Heating System Design Criteria

Before continuing with the installation of the Aeron<sup>3</sup> heat pump, please spend a few minutes confirming the suitability of the heat pump to your system.

Failure to do so may result in poor performance and wasted time:

- Has a room-by-room heat loss calculation been carried out?
- Is this system designed for mono or bivalent?
- If monovalent, total heating capacity?
- If bivalent, what is the load capacity of the heat pump?
- If bivalent, what is/are additional heat source(s)?
- Type of system design? - S-plan, S-plan plus
- Will a buffer be used?
- If yes, what is the capacity of the buffer?
- Has cavity wall insulation been installed?
- Has loft insulation of 270mm been installed?
- Have all system pipes been lagged correctly?
- Are the existing controls being upgraded?

### 3.2.1 System Design Criteria

A typical condensing oil or gas fired boiler operates with a flow of 70°C and a return of 50°C, i.e. with a DT of 20°C. A heat pump operates with a flow of between 30°C and 55°C with a DT of 8°C.

The design of any system in the IRL is typically based on the following parameters:

1. That the outside design air temperature can fall to -3°C or lower
2. The internal design temperature can be between 18-22°C depending on the room concerned.
3. The heat pump operates at lower water temperatures than an oil or gas fired appliance.

Designing a new system for use with a heat pump is straight forward, assuming the insulation properties of the dwelling meets or exceeds current Building Regulations and the lower flow/return temperatures are taken into account in the selection of the type and size of the heat emitters used.

While underfloor heating is the preferred heat emitter, a combination of underfloor heating and radiators, or radiators only, works just as efficiently. It is necessary, however, to calculate the size of radiator required accurately – if this is not done, the house will fail to reach the target temperature and will be costly to rectify after the installation is complete.

When tested to BS EN 14511, the heat output for an heat pump is declared at the test conditions of 7°C outside air temperature and 35°C or 55°C water flow temperature.

At all other values of outside air temperature and water flow temperature the actual heat pump output will vary, e.g. the heat output will:

- decrease with lower outside air temperatures and increase with higher outside air temperatures at any given water flow temperature, and
- decrease with higher water flow temperatures and increase with lower water flow temperatures at any given outside air temperature

A back-up boiler can be added to the rated output of the heat pump.

Provided that the heat pump is sized correctly for the system, this back-up heater will only compensate for any short fall in meeting the heat load for the property below the minimum design air temperatures.

### 3.2.2 Heat Emitter Sizing

For guidance on sizing heat emitters, e.g. radiators and/or underfloor heating, refer to SR50: 2010 code of practice for building services part 1 domestic plumbing and heating

### 3.3 Regulations

Installation of a Grant Aeron<sup>3</sup> heat pump must be in accordance with the following recommendations:

- National Building Regulations, e.g. Approved Document G
- Local Bylaws (check with the Local Authority for the area)
- Water Supply (Water Fittings) Regulations 1999
- MCS Installer Standards (if applying for the Renewable Heat Incentive)
  - MIS 3005 (Requirements for contractors undertaking the supply, design, installation, set to work commissioning and handover of microgeneration heat pump systems)
  - MCS 020 (MCS Planning Standards)
  - MCS 021 (MCS Heat Emitter Guide for Domestic Heat Pumps)

The installation should also be in accordance with the latest edition of the following standards and codes of Practice:

- BS 7671 and Amendments
- BS EN 12831

### 3.4 Heat Pump Location

#### 3.4.1 Selection of position

- Consider a place where the noise and the air discharged will not affect neighbours.
- Consider a position protected from the wind.
- Consider an area that reflects the minimum spaces recommended.
- Consider a place that does not obstruct the access to doors or paths.
- The surfaces of the floor must be solid enough to support the weight of the heat pump and minimise the transmission of noise and vibration.
- Take preventive measures so that children cannot reach the unit.
- Install the heat pump in a place where it will not be inclined more than 5°.
- When installing the heat pump where it may be exposed to strong wind, brace it securely.
- If the Aeron<sup>3</sup> heat pump is to be installed within 1 mile of the coast, avoid siting facing the sea.
- If the Aeron<sup>3</sup> heat pump is to be installed within 15 miles of the coast, the evaporator must be sprayed with AFC50 and this must be repeated on each annual service.

Decide the mounting position as follows:

1. Install the heat pump in a location which can withstand the weight of the heat pump and vibration. Please make sure it is installed level.
2. Provide the indicated space to ensure good airflow.
3. Do not install the heat pump near a source of heat, steam, or flammable gas.
4. During heating operation, condensate water flows from the heat pump. Therefore, install the heat pump in a place where the condensate water flow will not be obstructed.
5. Do not install the heat pump where strong wind blows directly onto the heat pump or where it is very dusty.
6. Do not install the heat pump where people pass frequently.
7. Install the heat pump in a place where it will be free from adverse weather conditions as much as possible.

#### 3.4.2 Noise Level

All heat pumps make a noise. Discuss the potential nuisance factor with the end-user when considering the final position of the heat pump. Take opening windows and doors into account. It is not essential for the heat pump to be positioned next to a wall of the house. Behind an out-building may be more suitable so discuss the options with the end-user.

#### 3.4.3 Orientation

The North face of the building will usually have colder ambient air than any other side. To ensure maximum efficiency from the Grant Aeron<sup>3</sup> heat pump, position the heat pump on a warmer side. In order of preference, site the heat pump on a South face followed by either South East or South West, then by East or West. Only install on a North face if there is no other alternative.

### 3.5 Preparation for Installation

#### 3.5.1 Base

The heat pump should be installed on a flat trowelled finished concrete base 150mm thick. This base should extend at least 150mm beyond the heat pump on three sides.

To avoid bridging the DPC, leave a gap of at approximately 150mm between the concrete base and the wall of the house.

The heat pump must be raised up from the base by approximately 100mm on suitable anti vibration mounts or blocks.

#### 3.5.2 Clearances

The following **minimum** clearances must be used to enable the product to be easily commissioned, serviced and maintained and allow adequate air flow in and out of the heat pump.

Refer to Table 3-1 and Figure 3-2.

**Table 3-1:** Clearances

Aspect	Minimum clearance required (mm)
Top	300
Bottom	Approximately 100*
Front	600
Rear	300
Left	100
Right	600

\* Height of A/V mounts (product code: HPIDFOOT/KIT)

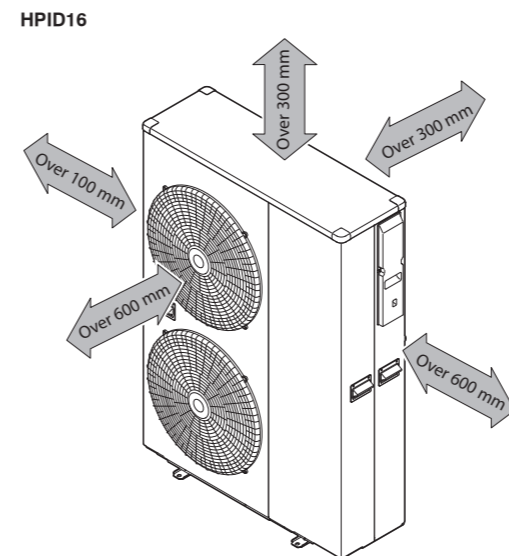
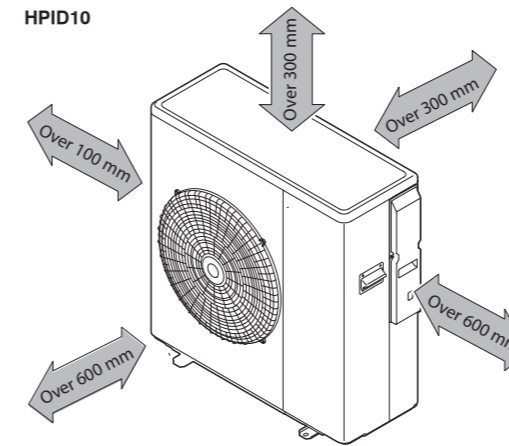
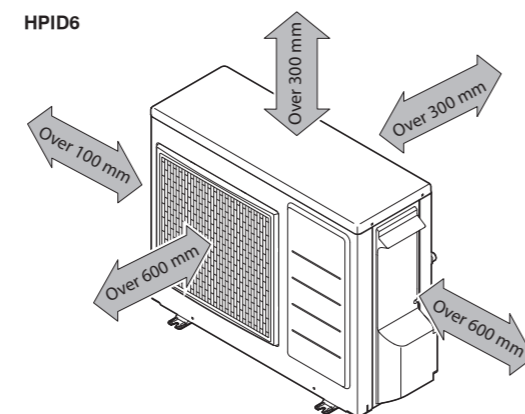

**Figure 3-2:** Clearances

#### 3.5.3 Condensate Disposal

The underside of the heat pump has a condensate outlet (refer to Figure 3-3) that allows any condensate to drain from the heat pump.

Provision must be made to safely collect and dispose of the condensate.

For example, use 40 mm waste pipe to form a condensate disposal system into which the condensate flows from the opening in the bottom of the heat pump casing running to a suitable gully or soakaway.



**It is essential that the condensate is able to drain away and not allowed to run onto any adjacent paths or driveways where, in winter, this will result in icing and a potential hazard for anyone walking near the heat pump. The top of the concrete base must be either level with, or above, the surrounding ground level.**

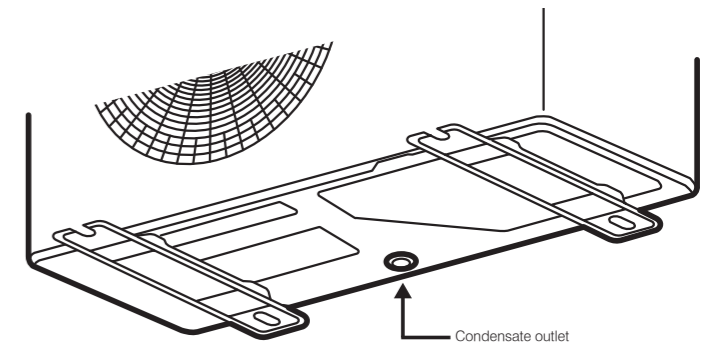

**Figure 3-3:** Condensate outlet

#### 3.5.4 Vibration

If the vibration from the heat pump is likely to cause a nuisance, use the anti-vibration mounts (product code: HPIDFOOT/KIT) and fix the heat pump securely to the mounts.

### 3.6 Installing the Heat Pump

#### 3.6.1 Insulation

The complete water circuit, including all pipework, must be insulated to prevent heat loss reducing the efficiency of the heat pump and also to prevent damage due to frozen pipes.

#### 3.6.2 Connecting the Heating System to the Heat Pump

- Water connections must be made in accordance with diagram in this manual and the labels on the heat pump.
  - Be careful not to deform the heat pump pipework by using excessive force when connecting.
  - Pipework should be flushed before connecting the heat pump.
  - Hold the pipe end downwards when removing burrs.
  - Cover the pipe end when inserting it through a wall so that no dust and dirt enter.
  - **The heat pump is only to be used in a sealed heating system. It must not be used as part of an open-vented system.**
- Before continuing the installation of the heat pump, check the following points:
- The maximum system water pressure is 3 bar.
  - Make sure the hose is connected to the pressure relief valve to avoid any water coming into contact with electrical parts.
  - Air vents must be provided at all high points of the system. The vents should be located at points which are easily accessible for servicing. An automatic air purge valve is provided inside the heat pump. Check that the air purge valve can operate.
  - Take care that the components installed in the pipework can withstand the water pressure.

#### 3.6.3 System Connections

The system connections of the heat pump must be carried out using the flexible hoses, valves and fittings supplied with the heat pump.

The hydraulic circuit must be completed following the recommendations below:

1. It is important to install the isolation valves between the heat pump and the building.
2. The system must have drain cocks in the lowest points.
3. Air vents must be included at the highest points of the system.
4. A system pressure gauge must be installed upstream of the heat pump.
5. All pipework must be adequately insulated and supported.
6. The presence of solid particles in the water can obstruct the heat exchanger. Therefore, protect the heat exchanger using a magnetic filter such as a Grant Mag-One.
7. After system assembly flush and clean the whole system, paying particular attention to the state of the filter.
8. A new installation must be thoroughly flushed and cleaned before filling and adding anti-freeze/biocide/inhibitor.



**Do not use the heat pump to treat industrial process water, swimming pool water or domestic drinking water. Install an intermediate heat exchanger for all of the above cases.**

### 3.6.4 Remote Controller

For details on how to install the remote controller, refer to Section 7.  
For setting, refer to Section 9.

### 3.7 Metering for Domestic RHI Installations

The current OFGEM requirements for the metering of ASHP installations for the domestic RHI involve both 'metering for payment' and 'metering for performance'.

#### 3.7.1 Metering for payment (heat meter)

Many domestic ASHP installations will not be required to be metered for payment, i.e. will not require a heat meter to be fitted.

The RHI payment will be based on the EPC annual heat pump demand for the property concerned.

Even if an ASHP installation is not required to be metered for payment, it must be 'meter ready' in accordance with MCS requirements. Refer to the MCS Domestic RHI Metering Guidance document for full details.

However, some domestic installations must be metered for payment if:

- The property is occupied for less than 183 days per year, e.g. a second home or holiday home.
- If there is a 'back-up' heating system installed, e.g. a fossil fuel appliance is used alongside the ASHP (such as with a hybrid system).

In the case of 'self build' (or 'custom build') homes, if the homeowners move into the property before the system is commissioned and have not lived in the property for a minimum of 183 days, the installation will either have to be metered for payment or they must wait at least 183 days before applying for the RHI.

A heat meter must be installed and regular meter readings will have to be submitted as the RHI payment will be determined from these readings.

#### 3.7.2 Metering for performance (electricity meter)

From the 22nd May 2018, all ASHP installation must be 'metered for performance' to meet OFGEM requirements for the Domestic RHI.

This basically requires that all ASHPs must be fitted with one (or more) electricity meters to record and display the electricity used by:

- The ASHP
- Any supplementary heaters for space heating, (e.g. an immersion heater in a buffer tank) controlled by the same control system as the ASHP
- Any immersion heater used to heat domestic hot water (DHW) controlled by the same control system as the ASHP (e.g. using a Grant Auto Boost Kit 2)

This metering on the electrical supply to the heat pump is NOT used to determine the Domestic RHI payment but to allow users to monitor the energy consumption and performance of their system.

Domestic RHI payments will continue to be based on either the EPC annual heat demand or a heater meter reading. Refer to 'meter for payment' section for details.

The electricity meter (or meters) used may be installed as either a separate 'stand-alone' meter for each device used, i.e. this may require up to three meters to be used on a single installation or a single 'stand-alone' meter for all devices used.

Where a single meter is used for more than one device, a separate sub-consumer unit will also be required to provide separate protection and isolation for each device concerned.

The electricity meters used must be MID compliant and Class A or better, remembering that classes B and C are better than A.

### 3.8 Volumiser Tanks

A 'Volumiser' tank is simply a vessel used to increase the volume of the system, to meet the system requirements as given below.

It will have only two connections, one inlet and one outlet, and it must be fitted in the return to the heat pump. Refer to Figure 3-5.

A 'Volumiser' tank will be required for the Grant Aerona<sup>3</sup> HPID16 (16kW) heat pump when:

- The overall system volume is less than 100litres
- OR
- If the part of the system connected to the heat pump is less than 30 litres during the normal operation of the system

For example:

- When the heating zone valves(s) are closed leaving only the primary circuit to a cylinder connected to the heat pump,
- OR
- When the hot water zone valve is closed leaving a heating zone (or zones) connected to the heat pump

The 'Volumiser' tank must be large enough to ensure that the volume of that part of the system will be at least 30 litres.

When operating at the factory default flow temperature of 55°C (parameter 4130) for domestic hot water production, a 'Volumiser' tank is NOT required for the Grant Aerona<sup>3</sup> HPID6 (6kW) or HPID10 (10kW) heat pumps.

The water pump, fitted in the heat pump, is supplied factory set at Level 3 (maximum output). It is unlikely that this level of output will be required, so it is recommended that the pump output is reduced to either Level 2 (medium output) or Level 1 (minimum output) as required. This will usually be indicated by achieving a temperature difference between the heat pump flow and return of approximately 8°C when the heating system is operating and up to temperature.

Refer to Section 8.3.6 for guidance on how to do change the pump output level.

To determine the temperature difference between flow and return, check the flow and return temperatures using the 'Monitor Display Function' on either the remote controller or Terminal PCB. Refer to Section 10.7 for guidance on how to check the flow and return water temperatures.

A 'Volumiser' tank will only be required for the Grant Aerona<sup>3</sup> HPID6 (6kW) and HPID10 (10kW) heat pumps when:

- The above mentioned system conditions exist AND the heat pump is operating at a flow temperature of 60°C for domestic hot water production.

A 30 litre 'Volumiser' tank, suitable for this purpose, is available from Grant IRL (product code: HPIDVOL30). For further information, please contact Grant IRL on +44 (0)1380 736920.

### 3.9 Hot Water Cylinders

When a Grant Aerona<sup>3</sup> HPID16 (16kW) heat pump is used with any model of Grant Heat Pump hot water cylinder, either a single or twin coil unit, a simple bypass MUST be fitted between the primary flow and return pipes at the cylinder.

This bypass consists of a 22mm pipe between the primary flow and return pipes, fitted with a 22mm gate valve.

Refer to Figure 3-4 for details.

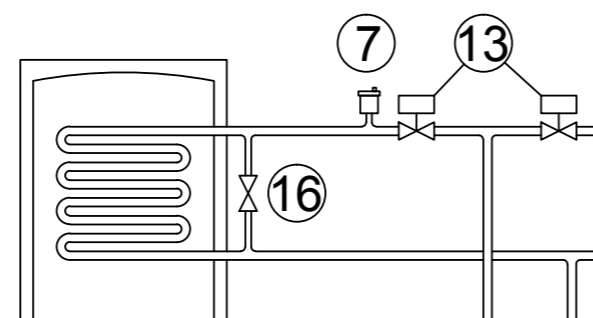

Figure 3-4: Cylinder coil bypass

This bypass must be set during commissioning, as follows:

First, set the water pump output to Level 1 (minimum). Refer to Section 8.3.6.

With the system operating to only heat the cylinder (i.e. with no space heating demand), progressively open the gate valve and reduce the flow of water through the cylinder coil enough to prevent any water flow noise from the cylinder.



**A bypass at the cylinder, as described above, is NOT required for the Grant Aerona<sup>3</sup> HPID6 (6kW) or HPID10 (10kW) heat pumps, but ONLY for the Grant Aerona<sup>3</sup> HPID16 (16kW) heat pump.**

Figure 3-5: Monovalent system - with S-Plan type controls

### 3.10 Hydraulic Diagram

The below system diagram is only a concept drawing, not a detailed engineering drawing, and is not intended to describe complete systems, nor any particular system.

It is the responsibility of the system designer, not Grant IRL, to determine the necessary components for and configuration of the particular system being designed including any additional equipment and safety devices to ensure compliance with building and safety code requirements.

Table 3-6: Key

Key	Description
1	Expansion vessel
2	Pressure gauge
3	Pressure relief valve
4	Tundish
5	Removable filling loop
6	Double check valve
7	Automatic air vent
8	Thermostatic radiator valve
9	Automatic bypass
10	Flexible hose
11	Isolation valve
12	Volumiser
13	Motorised 2-port valves
14	Optional additional circulating pump (refer to Section 8.3.7)
15	Drain point
16	Bypass - HPID16 (16kW) only

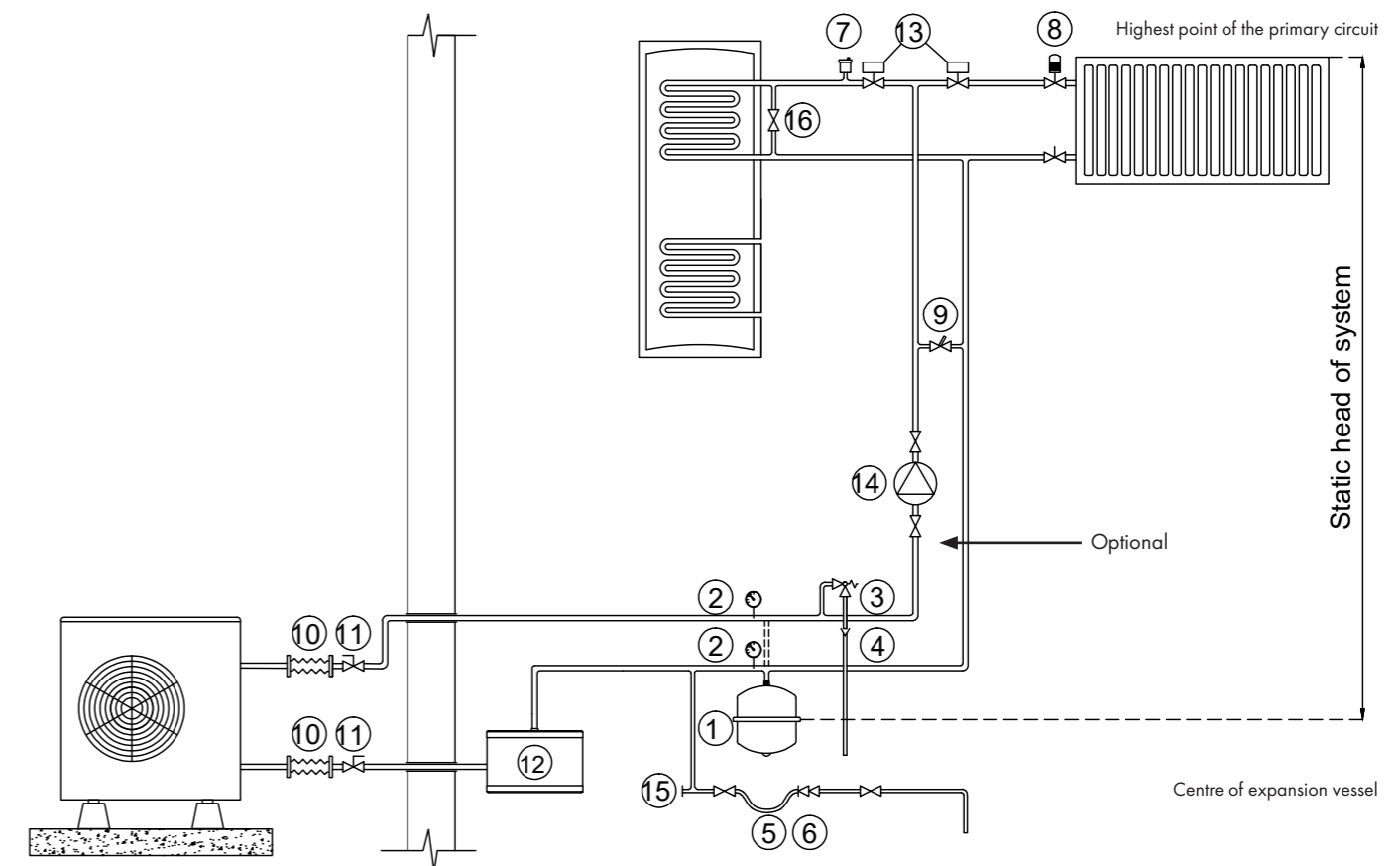

### 3.11 Before you Commission

#### 3.11.1 Flushing and Corrosion Protection

To avoid the danger of dirt and foreign matter entering the heat pump the complete heating system should be thoroughly flushed out – both before the heat pump is operated and then again after the system has been heated and is still hot.

This is especially important where the heat pump is installed as a replacement for a boiler on an existing system. In this case the system should be first flushed hot, before the old boiler is removed and replaced by the heat pump.

For optimum performance after installation, this heat pump and the central heating system must be flushed in accordance with the guidelines given in BS 7593 'Treatment of water in domestic hot water central heating systems'.

This must involve the use of a proprietary cleaner, such as Sentinel X300 or X400, or Fernox Restorer.

After flushing, a suitable thermal fluid should be used (such as Sentinel R600) specifically designed for use in air source heat pump installations. This provides long term protection against corrosion and scale as well as the risk of the freezing in the external section of the heating system (i.e. the flexible hoses, condenser and circulating pump within the heat pump casing) in the event of power failure during winter months.

In order to avoid bacterial growth, due to the lower system operating temperatures, a suitable Biocide (such as Sentinel R700) should also be used in conjunction with the thermal fluid. Both the thermal fluid and biocide should be added to the system water when finally filling the heating system.

Alternatively, Fernox HP-5C can be used. This is a suitable thermal fluid that protects against corrosion, scale and bacterial growth and also provides frost protection. The level of frost protection depends on the percentage concentration used.

Grant recommends using a suitable thermal fluid to give a MINIMUM level of frost protection of -9°C, and down to lower temperatures than this where local conditions are more severe.

Follow the instructions on the correct use of thermal fluids and biocides supplied with the products. Further information can be obtained from either [www.sentinel-solutions.net](http://www.sentinel-solutions.net) or [www.fernox.com](http://www.fernox.com).



**When using thermal fluids and biocides, ensure that the volume of any volumisers, buffers and thermal stores are taken into account, in addition to the heating system pipework, when determining how much is required to correctly dose the system.**

Failure to implement the above guidelines for fully flushing the system and using a suitable thermal fluid to provide adequate protection against corrosion, scale, bacterial growth and freezing will invalidate the heat pump product guarantee.

**Grant Engineering (IRL) ULC strongly recommends that a Grant Mag One in-line magnetic filter/s (or equivalent\*) is fitted in the heating system pipework. This should be installed and regularly serviced in accordance with the filter manufacturer's instructions.**

\* As measured by gauss. The Mag One magnetic filter has a gauss measurement of 12000.

**Table 3-7:** Antifreeze concentration

	% Monoethylene glycol inhibitor	10%	20%	30%	40%
		Freezing temperature *	-4°C	-9°C	-15°C
Correction factor	Capacity	0,996	0,991	0,983	0,974
	Power absorbed	0,990	0,978	0,964	1,008
	Pressure drop	1,003	1,010	1,020	1,033

\* The temperature values are indicative. Always refer to the temperatures given for the specified product used.

For details of how to access the parameter settings, refer to Section 9.3.

#### 3.11.2 Anti-freeze function setting

This function is factory set to ON, i.e. DIP SW1 is set to ON (up position).

With the frost protection function set to ON, it will operate as described in Sections 8.4.1, 8.4.2 and 8.4.3.

This function is not required if ethylene glycol is used in the heating system water to prevent freezing.

If a suitable concentration of ethylene glycol (heating system antifreeze) is used in the system water. Refer to Table 3-7 for suitable antifreeze concentrations or follow the manufacturer's instructions supplied with the antifreeze.

If not required, frost protection function can be disabled as follows:

- Remove the wiring cover at the right hand end of the heat pump. Refer to Figure 6-1.
- Set DIP SW1 to OFF (down position). Refer to Figure 3-8.
- Replace the wiring cover and secure in place with the screws provided.

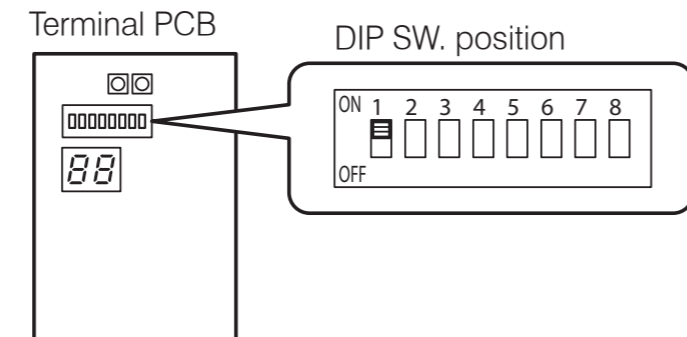

**Figure 3-8:** Anti-freeze function setting



**Dip switch positions:**  
Up: ON  
Down: OFF  
Refer to Sections 8.4.1, 8.4.2 and 8.4.3.

To do this, use the remote controller as follows (refer to Section 9.1 page 44):

First access the Installer level:

- Press and hold the Menu I and the – or + O buttons together for 3 seconds to enter the installer level.
- "InSt" parameter number "00 00" and parameter value "----" will be shown on the display. The first two digits of the parameter number will be blinking.

Then, access the Service level:

- Use the Up or Down Q buttons to change these first two digits to 99 and then press the + button O.
- The second two digits will then blink. Use the Up or Down Q buttons to change these two digits to 99 and then press the Set button P.
- The parameter value on the display will now be '0'.
- Use the 'Up' and 'Down' (8) buttons to change the parameter value to "738" and then press the 'Set' (7) button.

Now, reset the value for parameter 4300 to 0 (disabled):

- The first two digits of the 4-digit parameter number (the parameter group number) will blink.
- Set the parameter group number to 43 using the Up or Down Q button.

- Press the + buttons O and the second two digits (the parameter code) will blink.
- Set the parameter code number to 00 using the Up or Down Q button.
- Press Set button P and the parameter value 4300 (1 = enabled) will be displayed and will blink.
- Reset the parameter value 4300 to 0 (disabled) using the Up or Down Q button.

Repeat this process to reset the values of parameters 4310, 4320 and 4330 to 0.

Return to normal operation:

Press and hold the Menu I and the – or + O buttons together for 3 seconds or simply leave the remote controller for 10 minutes.



**Do NOT disable the heat pump antifreeze function unless a suitable concentration of glycol is present in the system water. Refer to Table 3-7. If there are any leaks of water from the heating system and the system requires topping up then the concentration of ethylene glycol must be checked and topped up as required. Failure to follow this instruction will invalidate the product guarantee.**

### 3.12 Completion

Please ensure that the heat pump commissioning form (supplied with the heat pump) is completed in full and that it is signed by the householder/user.

Leave the copy with the user and retain one copy for your own records.

Ensure that these installation and servicing instructions and the user instructions are handed over to the householder.

### 3.13 Installation Checklist

#### Location and positioning

- The vibration damping feet/shoes are fitted (if supplied)
- The heat pump is fixed to the surface or mountings that it rests on
- Maintenance clearances comply with those given in this manual
- The position of the remote controller complies with the guidance given in this manual
- All safety requirements have been complied with

#### Water circuit pipework and appliances

- Water connections have been carried out as per the information in this manual
- All water connections are tight with no leaks
- The magnetic in-line filter is installed on the primary circuit return as close to the heat pump as possible but still within the building and in a position that is easy to access for maintenance
- The pressure gauge with a suitable scale is installed on the sealed system pipework or expansion vessel manifold
- The connection pipes are suitably supported so that these do not weigh on the appliance
- The expansion vessel installed on the heating circuit is suitably sized
- The low-loss header or volumiser tank is installed if the water content is insufficient (16kW unit only - refer to Section 3.8)
- The water circuit has been thoroughly flushed
- The air vent valves are installed at the highest points on the system
- There is no air in the system (vent if necessary)
- The shut off valves are installed on the inlet/outlet of system circuit
- The drain valves are installed at the lowest points in the system
- The flexible hoses are installed on the inlet/outlet of system circuit
- The system water content complies with the specification in the manual
- The DHW immersion heater has been installed in DHW tank for Legionella prevention
- Suitable water flow rate for operation of the entire heat pump is achieved as specified in this manual. Refer to Section 9.12
- All pipes are insulated with suitable vapour barrier material to prevent formation of condensation and heat loss, with control and shut-off devices protruding from the insulation

#### Electrical connections

- All electrical connections are secure
- Electrical connections have been carried out correctly
- Voltage is within a tolerance of 10% of the rated voltage for the heat pump (230V)
- Electrical power supply complies with the data on the rating plate and as specified in the manual
- The earth wires are connected securely

**Table 3-9:** Frost protection parameters

Level	Parameter		Function description	Display and input value				Remarks
	Group	Code		Default	Min.	Max.	Unit	
S	43	00	Frost protection on room temperature 0=disable 1=enable	1	0	1	-	
S	43	10	Frost protection by outside temperature 0=disable 1=enable	1	0	1	-	
S	43	20	Frost protection based on outgoing water temperature 0=disable 1=enable	1	0	1	-	
S	43	30	DHW storage frost protection 0=disable 1=enable	1	0	1	-	



3.14 Installation Checklist

<b>Client name:</b>	
<b>Installation address:</b>	
<b>Heat pump model:</b>	
<b>Installer:</b>	
<b>Merchant:</b>	

	Yes	No
<b>Heat pump mounting</b>		
Is the outdoor unit mounted allowing correct distances from adjacent boundaries		
Is the outdoor unit correctly installed on the anti-vibration mounts - feet or arms		
Is the outdoor unit mounted level on concrete base		
Has condensate drain been connected to soakaway		
<b>Plumbing works</b>		
Has correct size flow and return pipework been fitted		
Have heat pump isolation valves been fitted externally		
Is primary flow and return pipework insulated		
Have flexible hoses provided with heat pump been fitted		
Has the cylinder been fully connected to the heating and plumbing system		
Has the heating expansion vessel been secured and charged to correct pressure		
Has the potable expansion vessel been secured and charged to correct pressure		
Are all isolating valves and pump valves open		
Has the system been fully purged of air and pressurised to the correct value		
Has volumizer/buffer tank been fitted on the return		
Has magnetic filter been fitted on the return pipework to heat pump		
Has all glycol that has been provided been added to the system		

<b>Rads/UFH</b>		
Has all air been vented from radiators		
Have all radiators been balanced		
If underfloor, have all correct flowrates been set		
Are all actuators and wiring centres been fully wired and connected		
<b>Electrical</b>		
Has correct size RCBO been fitted to heat pump supply		
Has external isolation switch been secured beside heat pump		
Has correct size mains cable been used		
Has correct size cable been ran from heat pump to wiring centre		
Has correct sized cable been ran from heat pump to controller		
Have all cables been ran from motorised valves/underfloor wiring centres etc to Grant wiring centre		
Has correct size cable been ran from board to immersion		
Has time boost kit been wired into immersion supply		
Has cylinder stat been fitted and wired back to Grant wiring centre		
Are all connections been correctly made in Grant wiring centre		
Are all heating controls fully wired and working		
Are all underfloor stats wired back to corresponding actuators		

Installer signature: \_\_\_\_\_

Date: \_\_\_\_\_

# 4 SEALED SYSTEMS

## 4.1 Sealed System Requirements

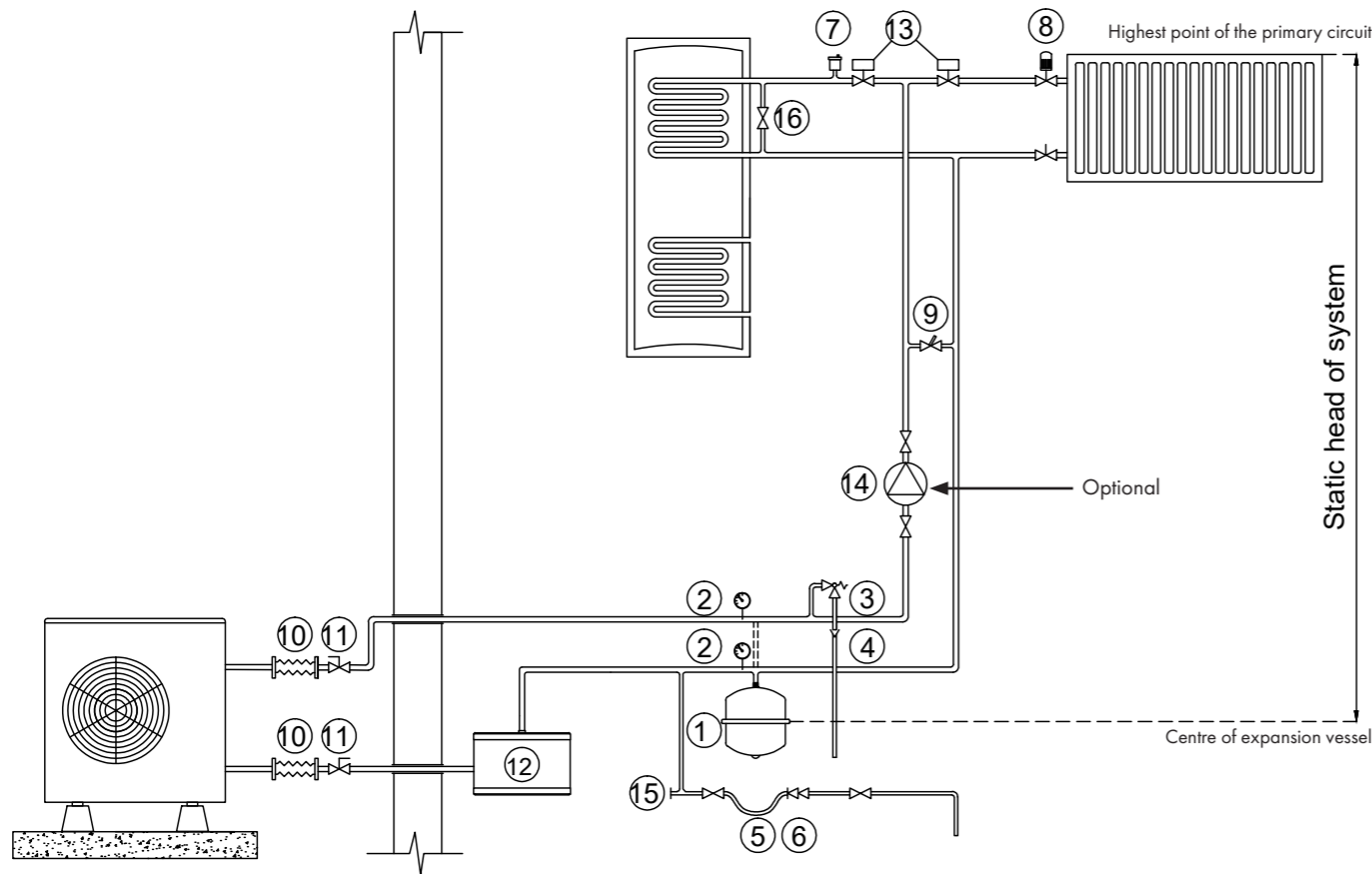

Figure 4-1: Sealed System heating components

Table 4-2: Sealed System heating components key

Key	Description
1	Expansion vessel
2	Pressure gauge
3	Pressure relief valve
4	Tundish
5	Removable filling loop
6	Double check valve
7	Automatic air vent
8	Thermostatic radiator valve
9	Automatic bypass
10	Flexible hose
11	Isolation valve
12	Volumiser
13	Motorised 2-port valves
14	Optional additional circulating pump (refer to Section 8.3.7)
15	Drain point
16	Bypass - HPID16 (16kW) only

All Grant Aeron<sup>3</sup> heat pumps must be used with sealed systems complying with the requirements of BS EN 12828, BS EN 12831 and BS EN 14336.

The system must be provided with the following items:

- Diaphragm expansion vessel complying with BS EN 13831
- Pressure gauge
- Pressure relief (safety) valve
- Approved method for filling the system

### Expansion vessel

The expansion vessel can be fitted in either the return or flow pipework in any of the recommended positions as shown in Figure 4-1. To reduce the operating temperature of the expansion vessel, position it below the pipe to which it is connected.

The expansion vessel may be positioned away from the system, providing the connecting pipe is not less than 13 mm diameter. If the expansion vessel is connected via a flexible hose, care must be taken to ensure that the hose is not twisted.



**Ensure that the expansion vessel used is of sufficient size for the system volume. Refer to BS 7074:1:1989 or The Domestic Heating Design Guide for sizing the required vessel.**

### Pressure Gauge

The pressure gauge must have an operating range of 0 to 4 bar. It must be located in an accessible place next to the filling loop for the system.

### Safety Valve

The safety valve (provided with the heat pump) is set to operate at 3 bar. It should be fitted in the flow pipework near to the heat pump.

The pipework between the safety valve and heat pump must be unrestricted, i.e. no valves. The safety valve should be connected to a discharge pipe which will allow the discharge to be seen, but cannot cause injury to persons or damage to property.

### Filling Loop

Provision should be made to replace water lost from the system. This can be done manually (where allowed by the local water undertaking) using an approved filling loop arrangement incorporating a double check valve assembly.

The filling loop must be isolated and disconnected after filling the system.

### Heating System

The maximum 'setpoint' temperature for the central heating water is 55°C.

An automatic air vent should be fitted to the highest point of the system.

If thermostatic radiator valves are fitted to all radiators, a system by-pass must be fitted. The by-pass must be an automatic type and correctly set when the system is commissioned.

All fittings used in the system must be able to withstand pressures up to 3 bar. Radiator valves must comply with the requirements of BS 2767:1991.

One or more drain taps (to BS 2879) must be used to allow the system to be completely drained.

## 4.2 Filling the Sealed System

Filling of the system must be carried out in a manner approved by the local Water Undertaking.



**Only ever fill or add water to the system when it is cold and the heat pump is off. Do not overfill.**

WARNING

The procedure for filling the sealed system is as follows:

1. Check the air charge pressure in the expansion vessel BEFORE filling the system.

The expansion vessel charge pressure should always be approximately 0.2 bar lower than the maximum static head of the system, at the level of the vessel (1 bar = 10.2 metres of water).

Refer to Figure 4-1.

**The charge pressure must not be less than the actual static head at the point of connection.**

2. Check that the small cap (or screw) on all automatic air vents is open at least one turn. The cap (or screw) remains in this position until filling is completed and then it is closed.
3. Remove the top (6kW) and front right (10kW and 16kW) casing and loosen the plug on the automatic air vent located inside the heat pump. Refer to Figure 4-3.

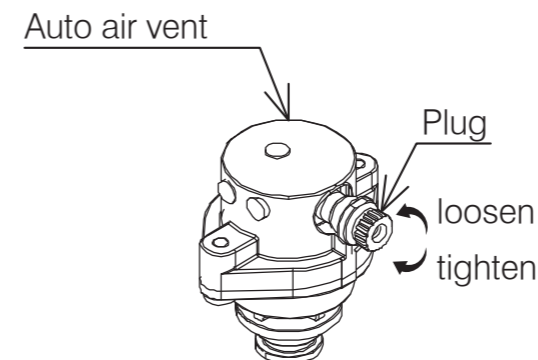

Figure 4-3: Auto Air Vent

4. Ensure that the flexible filling loop is connected and that the double

check shut off valve connecting it to the water supply is closed. A valve is open when the operating lever is in line with the valve, and closed when it is at right angles to it.

5. Open the fill point valve.
  6. Gradually open the double check valve from the water supply until water is heard to flow.
  7. When the needle of the pressure gauge is between 0.5 and 1.0 bar, close the valve.
  8. Vent each radiator in turn, starting with the lowest one in the system, to remove air.
  9. Continue to fill the system until the pressure gauge indicates between 0.5 and 1.0 bar. Close the fill point valve. The system fill pressure (cold) should be 0.2 - 0.3 bar greater than the vessel charge pressure – giving typical system fill pressures of approx 0.5 bar for a bungalow and 1.0 bar for a two storey house.
- Refer to the Domestic Heating Design Guide for further information if required.
10. Repeat steps 8 and 9 as required until system is full of water at the correct pressure and vented.
  11. Water may be released from the system by manually operating the safety valve until the system design pressure is obtained.
  12. Close the fill point and double check valves either side of the filling loop and disconnect the loop.
  13. Check the system for water soundness, rectifying where necessary.



**The air charge pressure may be checked using a tyre pressure gauge on the expansion vessel Schraeder valve. The vessel may be re-pressurised, when necessary, using a suitable pump. When checking the air pressure, the water in the heating system must be cold and the system pressure reduced to zero.**

NOTE

## 4.3 Pressure Relief (Safety) Valve Operation

Check the operation of the pressure relief (safety) valve as follows:

1. Turning the head of the valve anticlockwise until it clicks. The click is the safety valve head lifting off its seat allowing water to escape from the system.
2. Check that the water is escaping from the system.
3. Top-up the system pressure, as necessary.



**The expansion vessel air pressure, system pressure and operation of the pressure relief valve must be checked on each service. Refer to Section 10.**

NOTE

# 5 DOMESTIC HOT WATER

## 5.1 Temperature Control

If a DHW demand is made, the heat pump will continue to provide space heating for a minimum period of 15 minutes (parameter 3122 - refer to Table 5-1). If space heating is already being demanded and has been on for this minimum period, then the heat pump will change over to prioritise DHW.

In either case, once DHW is being provided, the flow temperature will target 55°C, irrespective of the space heating target temperature. Also note that there is no weather compensation control when in DHW mode.

The time limit for DHW can be set using parameter 3121. The default setting is 60 minutes but you may want to increase or decrease this time period. After this time period has been reached, the heat pump will default back to the original demand that was in place prior to the DHW demand or to a stand by state if the change is demand state occurred during the DHW demand.

If the unit times out on parameter 3121, remember the motorised valve of the DHW circuit will remain open as it is controlled by the cylinder thermostat and not the heat pump and will not heat up to the correct temperature when using the space heating flow temperature. It is also possible that the cylinder could be robbed of heat to the space heating circuit if the stored water is hotter than the flow temperature to the space heating circuit.

If the motorised valve for space heating is open during DHW demand, the 55°C flow temperature will also enter the space heating circuit, increasing the recovery time of the cylinder.

To minimise this high temperature period and higher than normal running costs, ensure that space heating and DHW demand times to not occur simultaneously.

## 5.2 Heat Pump Cylinders

As the water temperature from the heat pump is lower than from a traditional system using a boiler, a much larger coil is required inside the cylinder to transfer the heat efficiently.

**Table 5-1:** DHW and space heating parameters

Level	Parameter		Function description	Display and input value				Remarks
	Group	Code		Default	Min.	Max.	Unit	
I	31	21	Maximum time for DHW request	60	0	900	1 min	
I	31	22	Minimum time for space heating	15	0	900	1 min	

For details of how to access the parameter settings, refer to Section 9.3.

Grant Irl has a full range of high efficiency cylinders available from 200ltr to 300ltr in mono and duo wave cylinders.

In order to ensure that a minimum of at least 8K temperature difference is maintained between cylinder flow and return, the correct Grant IRL heat pump cylinder must be selected to match the heat pump output.

Failure to use the correct cylinder can result in a reduced heat transfer in the cylinder and a lower temperature differential.

## 5.3 Legionella

It is possible to use the heat pump to raise the HW cylinder to around 50 to 55°C.

For protection against Legionella the temperature can be periodically raised to 60°C using the Grant Automatic DHW Boost Kit 2, available from Grant IRL (product code: HPDHWBK2).

This boost kit also allows the cylinder immersion element to be used to raise the temperature to 60°C for one hour either daily or weekly to sterilise the cylinder against Legionella.



**For this system to operate, the existing immersion switch must be left set permanently to ON.**

**To totally prevent operation of the immersion element, the existing immersion switch must be set to OFF.**

### 5.3.1 Legionella Sanitisation Regime

Care must be given to vulnerable people who may be exposed to potentially life-threatening legionella. This group of people include the elderly, pregnant women, young children and those with breathing difficulties.

Care must also be given to households who do not use a lot of water on a daily basis. While this chart is not exhaustive, it is important that you discuss any potential issues with the occupants before deciding on the appropriate regime. It is important that this decision is based on the welfare of the occupants and not on energy saving measures.

**Table 5-2:** Legionella group sanitisation regime

	Uses less than 50 litres of hot water per day	Uses more than 50 litres of hot water per day
Vulnerable Group	Store at 50°C and raise hot water cylinder to 60°C for 1 hour every day	Store at 50°C and raise hot water cylinder to 60°C for 1 hour every 3 days
Non-Vulnerable Group	Store at 50°C and raise hot water cylinder to 60°C for 1 hour every week	Store at 50°C and raise hot water cylinder to 60°C for 1 hour every 2 weeks

## 5.4 Automatic DHW Boost Kit

This system uses both the existing cylinder immersion heater and cylinder thermostat. This is switched via a contactor operated by a small timeswitch, both enclosed in a separate unit to be mounted next to the cylinder. Thus the immersion element can be programmed to operate for the required period on either a daily or weekly basis.

Once set, this system is fully automatic but can be overridden by the user if required. Also, the user can still switch the immersion element off, via the immersion heater switch, irrespective of the programmer or cylinder thermostat setting or whether the heat pump is operating.

### 5.4.1 Installation

The Automatic DHW Boost Kit 2 comes pre-wired within its enclosure, ready for installation. The connections to the Immersion heater switch and immersion heater must be made after it is installed on site.

When installed, this kit interrupts the electrical supply between the existing immersion heater switch and immersion heater. Refer to Figure 5-4 for electrical connection details.

In order to connect and use this kit the existing cylinder thermostat must have two output terminals; one 'make on rise' (normally open) contact and the other 'break on rise' (normally closed) contact. If not, then the cylinder thermostat MUST be replaced with one that does have two output terminals.

The use of any other type of cylinder thermostat, or any modification to an existing thermostat, will invalidate the product guarantee and may result in a potentially dangerous installation.

### IMPORTANT

**Do not alter the pre-wired connections within the enclosure and only make the external connections as shown in the wiring diagrams. See Figure 5-4.**



**Where a 3-phase supply is present, ensure that BOTH the immersion switch and heating system controls are taken from the same phase. If in doubt, contact a qualified electrician.**

### 5.4.2 Setting

To set the timeswitch use the following procedure:

#### To set the time and day:

1. Press and hold down the 'clock' button throughout the 'time and day' setting process.
2. Press 'h+' button repeatedly to set hour (24 hour clock).
3. Press 'm+' button repeatedly to set minutes.



The hot water controls must be 'calling' for this switch to bring the immersion on.



If you hold down either the 'h+' or 'm+' buttons for longer than a second the figures in the display will scroll continuously.

NOTE

4. Press the 'day' button repeatedly to scroll through to required day of week.
5. Release the 'clock' button. The clock is now running as indicated by the flashing colon.

#### To set switching times:

You can set up to six ON and OFF commands per day, if required, as follows:

1. Press the 'timer' button. The actual time will disappear from the display. The first 'ON' indication will be displayed.
2. Press 'h+' button repeatedly to set hour (24 hour clock).
3. Press 'm+' button repeatedly to set minutes.
4. Press the 'day' button repeatedly to scroll through day options – each single day, all weekdays, weekend and entire week.
5. Press the 'timer' button again. The first 'OFF' indication will be displayed.
6. Repeat steps 2 to 4 (above) to set first OFF time – hours minutes and day.



Ensure that day (or days) for the OFF setting match those for the ON setting.

8. Press the 'timer' button again. The second 'ON' indication will be displayed.
9. Repeat the above procedure to set second ON and OFF times, if required.
10. After setting all required ON and OFF times – press the 'clock' button to return to current time display.

#### To check ON/OFF settings

Repeatedly press the 'timer' button to scroll through all ON and OFF settings.

#### To change an ON or OFF setting

When a setting is showing on the display – press the 'h+' 'm+' or 'day' buttons to alter the setting as required.

#### To delete an ON/OFF setting period

1. Press the 'timer' button until the 'ON' setting for the period to be deleted is displayed.
2. Press the 'h+' button repeatedly until '-' appears (after 23 hours).
3. Press the 'm+' button repeatedly until '-' appears (after 59 minutes).
4. Press the 'timer' button and the 'OFF' setting for the period to be deleted is displayed.
5. Repeat steps 2 and 3 (above) to delete the 'OFF' setting.
6. Press the 'timer' button to save the amended command.
7. The deleted ON/OFF period is now available for re-programming if required.
8. Press the 'clock' button to return to the current time display.

#### To override the timeswitch

If timeswitch is ON - press the 'override' button to set timeswitch to OFF.

If timeswitch is OFF – press the 'override' button to set timeswitch to ON.

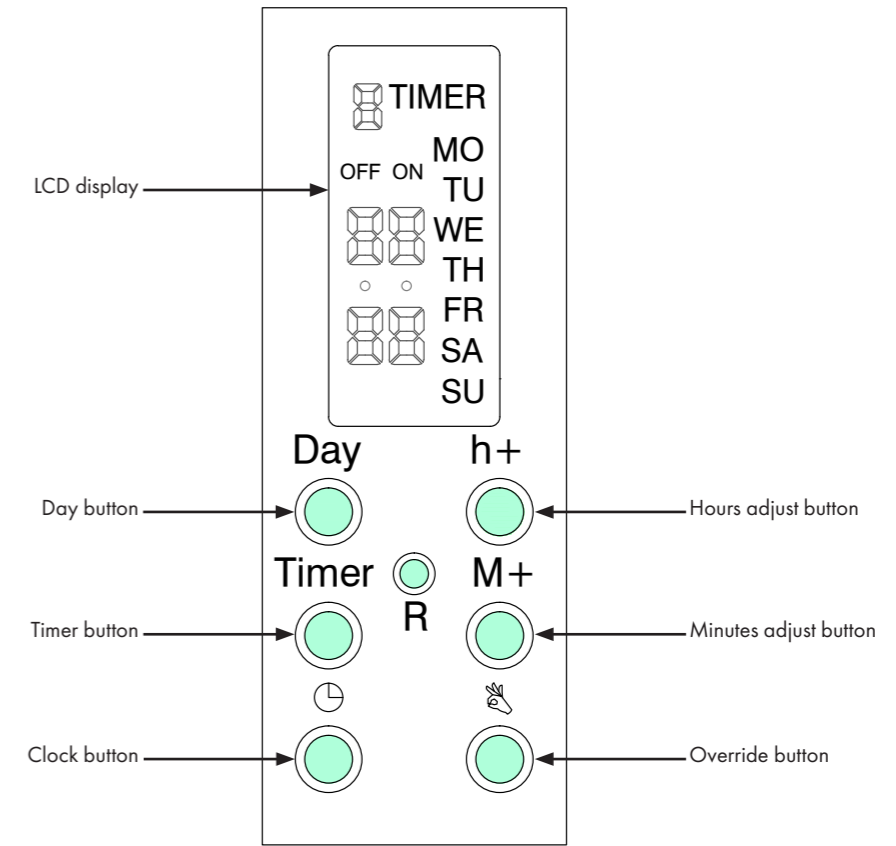

Figure 5-3: Boost kit timeswitch

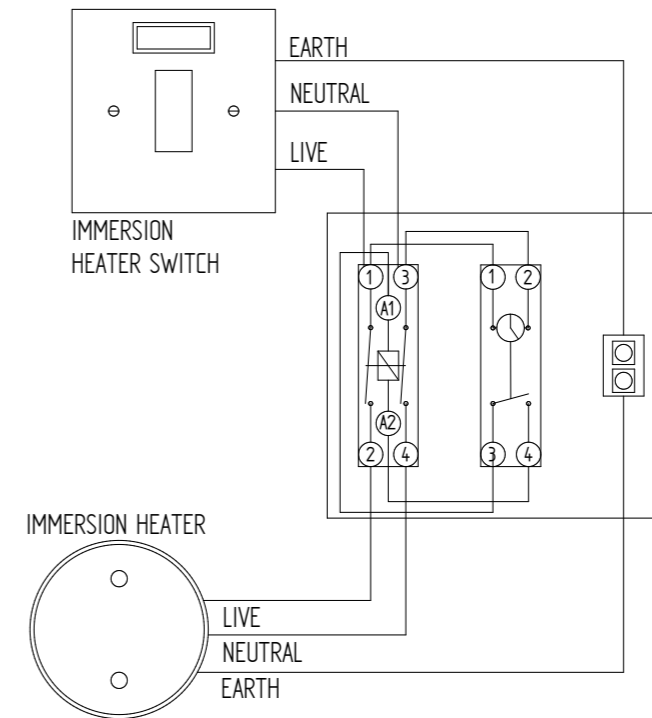

Figure 5-4: Boost kit wiring diagram

# 6 ELECTRICAL

## 6.1 Main PCB



**Electric shock may cause serious personal injury or death.**  
**All electrical work must be undertaken by a competent person. Failure to observe this legislation could result in an unsafe installation and will invalidate all guarantees.**  
**All electrical connections made on-site are solely the responsibility of the installer.**

All wiring connections are made to the Terminal PCB (refer to Figure 6-1) and terminal block (refer to Figure 6-3) inside the heat pump.

To access these connections, remove the wiring cover at the right hand end of the heat pump.

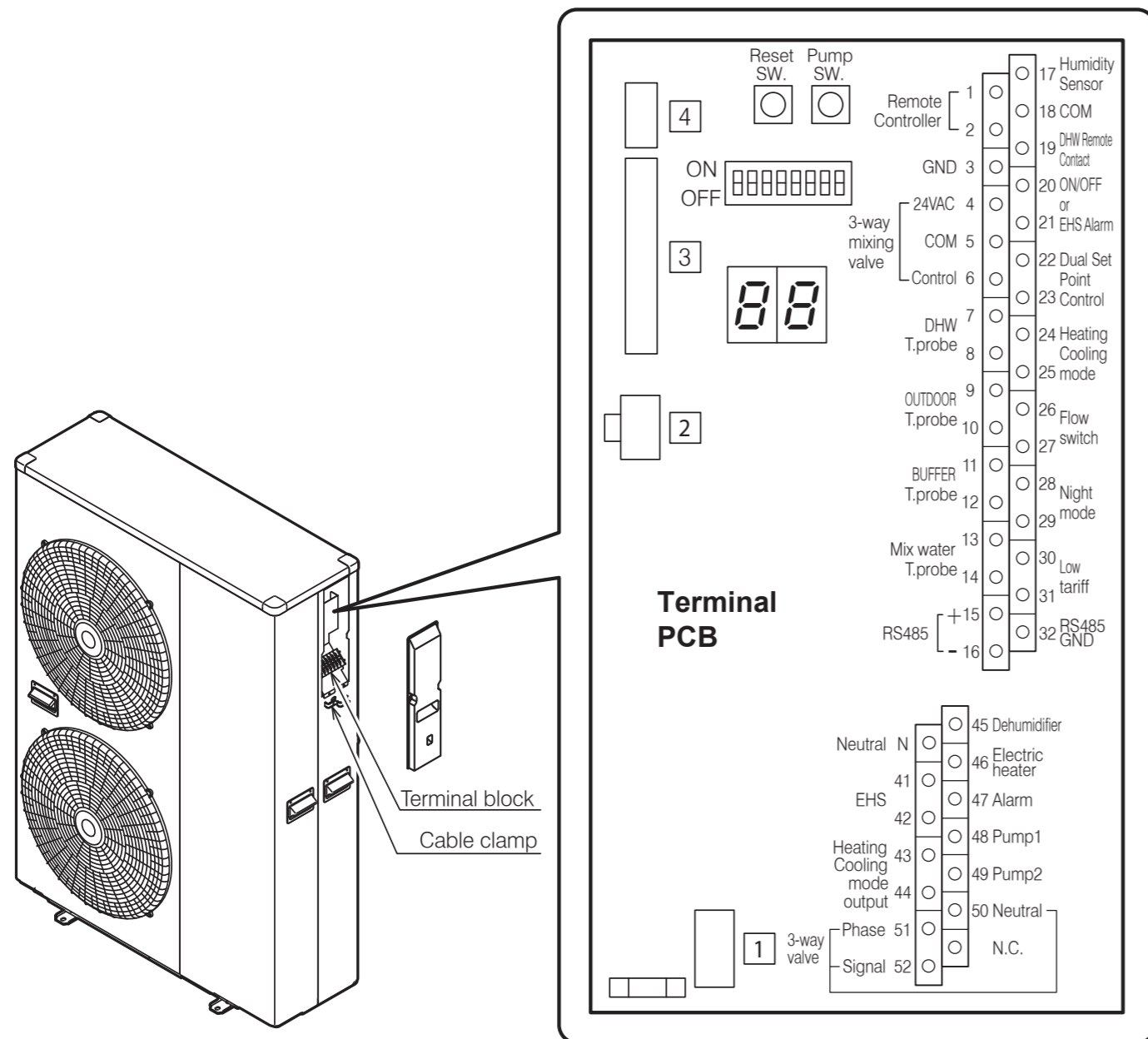

Figure 6-1: Terminal PCB

## 6.2 Terminal PCB Input/Output

### Serial connections

Terminal	Function	Analogue Input	Digital Input
1 - 2 - 3	Remote controller	1=S1, 2=S2, 3=GND	Wire length is maximum 100m with 1mm <sup>2</sup> shielded cables

### Analogue/Digital INPUTS

Table 6-2: Terminal PCB input/outputs

Terminal	Function	Analogue Input	Digital Input
19 - 18	DHW remote contact		Voltage free contact 12V10mA
20 - 21	Configurable input -ON/OFF remote contact		
28 - 29*	Night mode - optional		
30 - 31*	Low tariff - optional		

\* Requires external timer

For details of how to access the parameter settings, refer to Section 9.3.

## 6.3 Power Supply

Use a dedicated power supply with a correctly sized circuit breaker.

The final power supply connection must be made from a weatherproof lockable isolator located outside the building.

The cable should be either armoured or run in a flexible conduit between the isolator and heat pump.

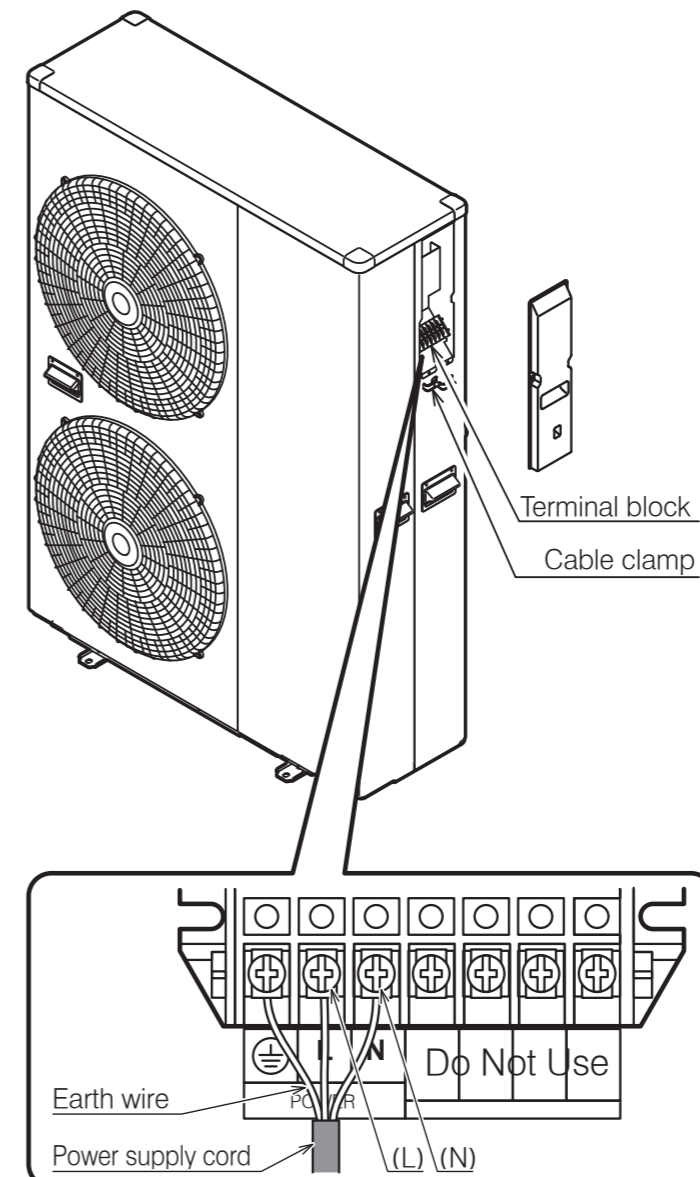

Figure 6-3: Power supply

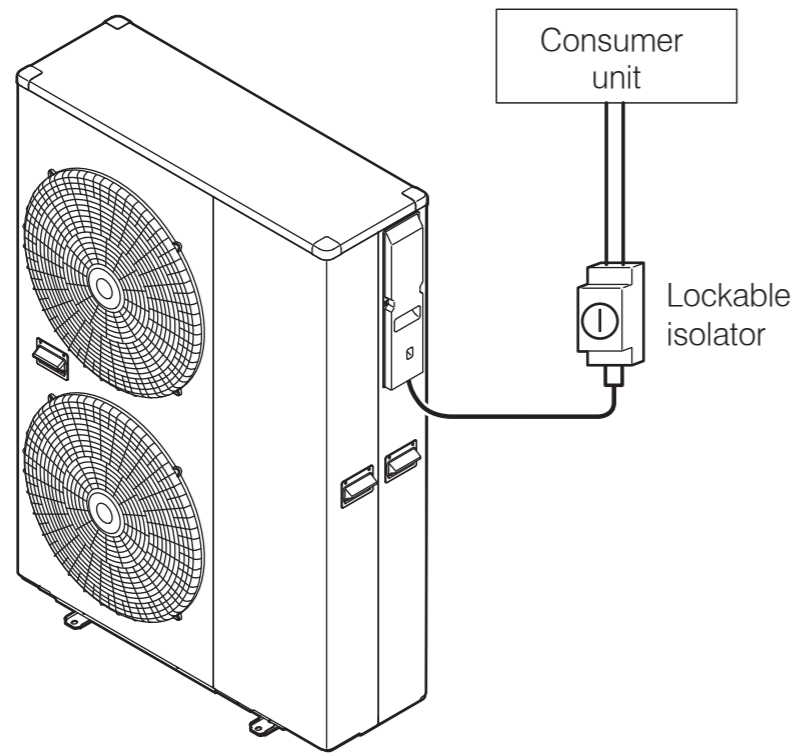

Figure 6-4: Heat pump, isolator and consumer unit

#### 6.4 Wiring first fix options

##### Mains supply

All heat pump models to have a twin and earth from main fuse board wired to outdoor unit through an external isolator

6kW – 3 x 2.5mm<sup>2</sup> – 16A RCBO

10kW – 3 x 4mm<sup>2</sup> – 20A RCBO

12/16kW – 3 x 6mm<sup>2</sup> – 32A RCBO

##### Grant wiring centre – located in cylinder area

3 x 1.5mm<sup>2</sup> mains supply to wiring centre

3 x 1.5mm<sup>2</sup> shielded cable from heat pump (outdoor) to wiring centre

##### Heat pump controller

2 x 1mm<sup>2</sup> shielded cable from outdoor unit to heat pump controller

##### Immersion

3 x 2.5mm<sup>2</sup> from main fuse board to immersion wired through grant supplied time boost kit

##### Cylinder Stat

Live & Neutral – linked from L&N on Grant wiring centre – 2 x 1.5mm<sup>2</sup>

Load & Common – 2 x 1mm<sup>2</sup> from wiring centre to cylinder stat

##### If underfloor heating is present

Boiler call cable from underfloor heating wiring centre/s to Grant wiring centre – 2 x 1mm<sup>2</sup>

UFH circulating pump/valve wired back to Grant wiring centre – 2 x 1mm<sup>2</sup>



NOTE

**In the case of long cable runs, selection of correct cable must be done in accordance with BS 7671 (IET Wiring Regulations)**

Strip ends of connecting cables in accordance with Figure 6-6.

Crimp terminals with insulating sleeves can be used if required as illustrated in the diagram below for connecting the wires to the terminal block. Stranded conductors shall not be soldered.

- Use a circuit breaker with a 3 mm clearance of air gap between the contacts.
- Be sure to FULLY insert the cable cores into the proper position of the terminal block.
- Faulty wiring may cause not only abnormal operation but also damage to PCB board.
- Fasten each terminal screw securely.
- To check the connections are secure, pull the cable slightly.

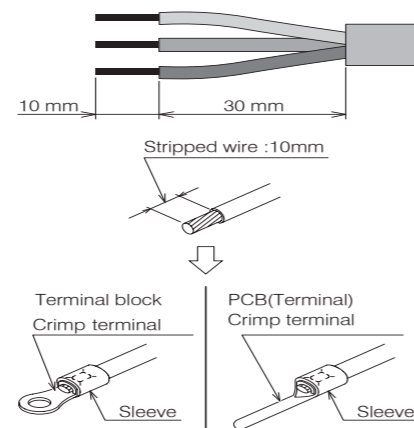

Figure 6-5: Stripping the cables



CAUTION

**It is important that the cable is stripped back 10mm. If shorter, it is possible to clamp down onto the insulation. If longer, a short circuit may occur.**

#### 6.5 Tightening Torques

Table 6-6: Tightening torques



WARNING

**When using crimp type terminals, tighten the terminal screws to the specified torques, otherwise, overheating may occur and possibly cause extensive damage inside the heat pump.**

#### 6.6 Solar Thermal

It may be part of the system design to incorporate solar thermal.

This is easily done with the use of an additional two-pole relay.

This can, of course be added to both monovalent and bivalent systems. It is much easier to carry out all these types of systems based on S-plan type controls only.

Y and W type plans can be used, but the need for additional relays is not practical. It is much easier to convert Y and W type plans to S types from the start.

#### 6.6 Connection of Heating System Controls

For information relating to the connection of the heating system controls, refer to Figures 6-8 or 6-9.

#### 6.7 Connection of Remote Controller

For information relating to the connection of the remote controller, refer to Section 7.

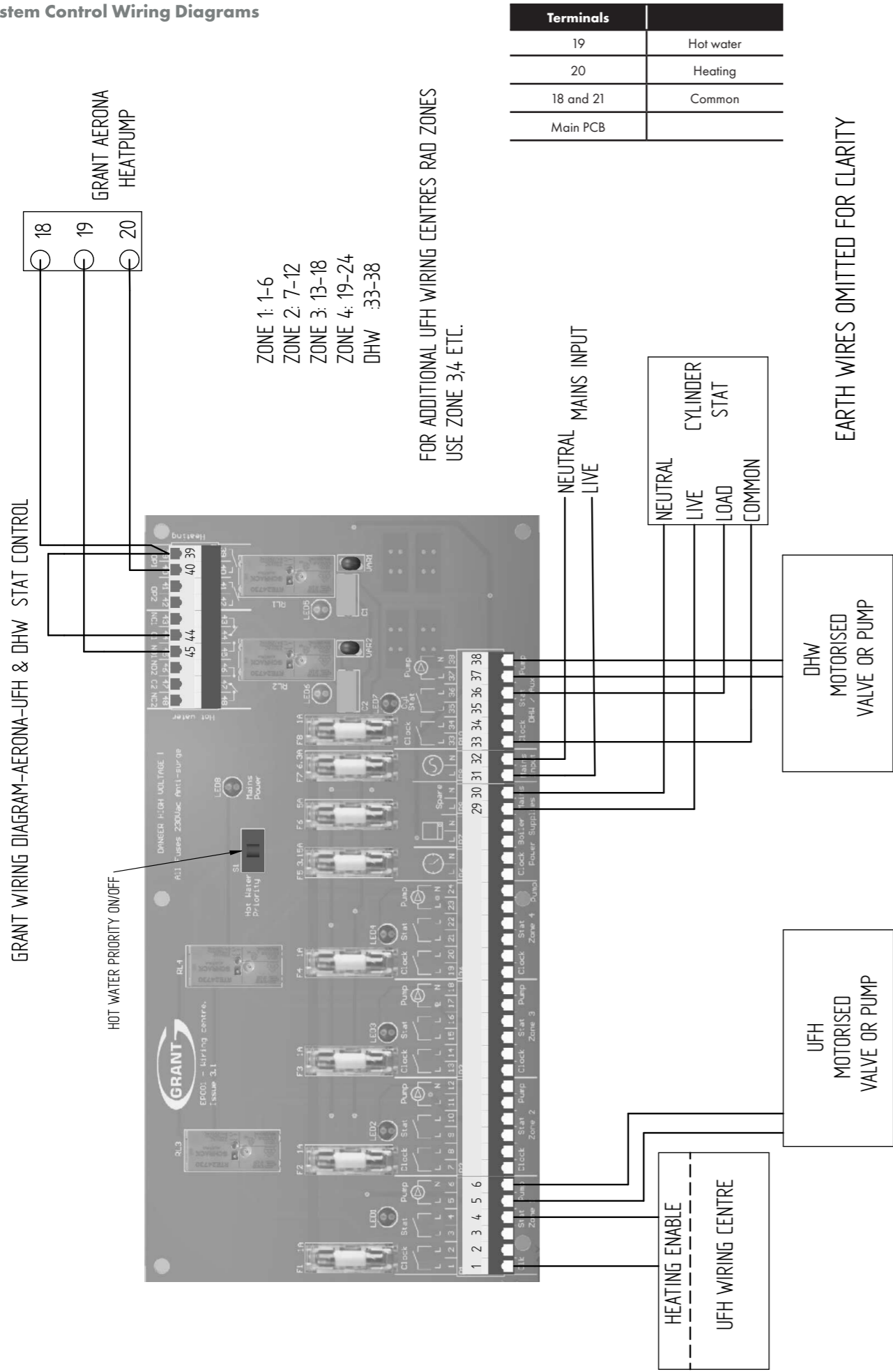

Figure 6-8: Wiring centre - UFH only

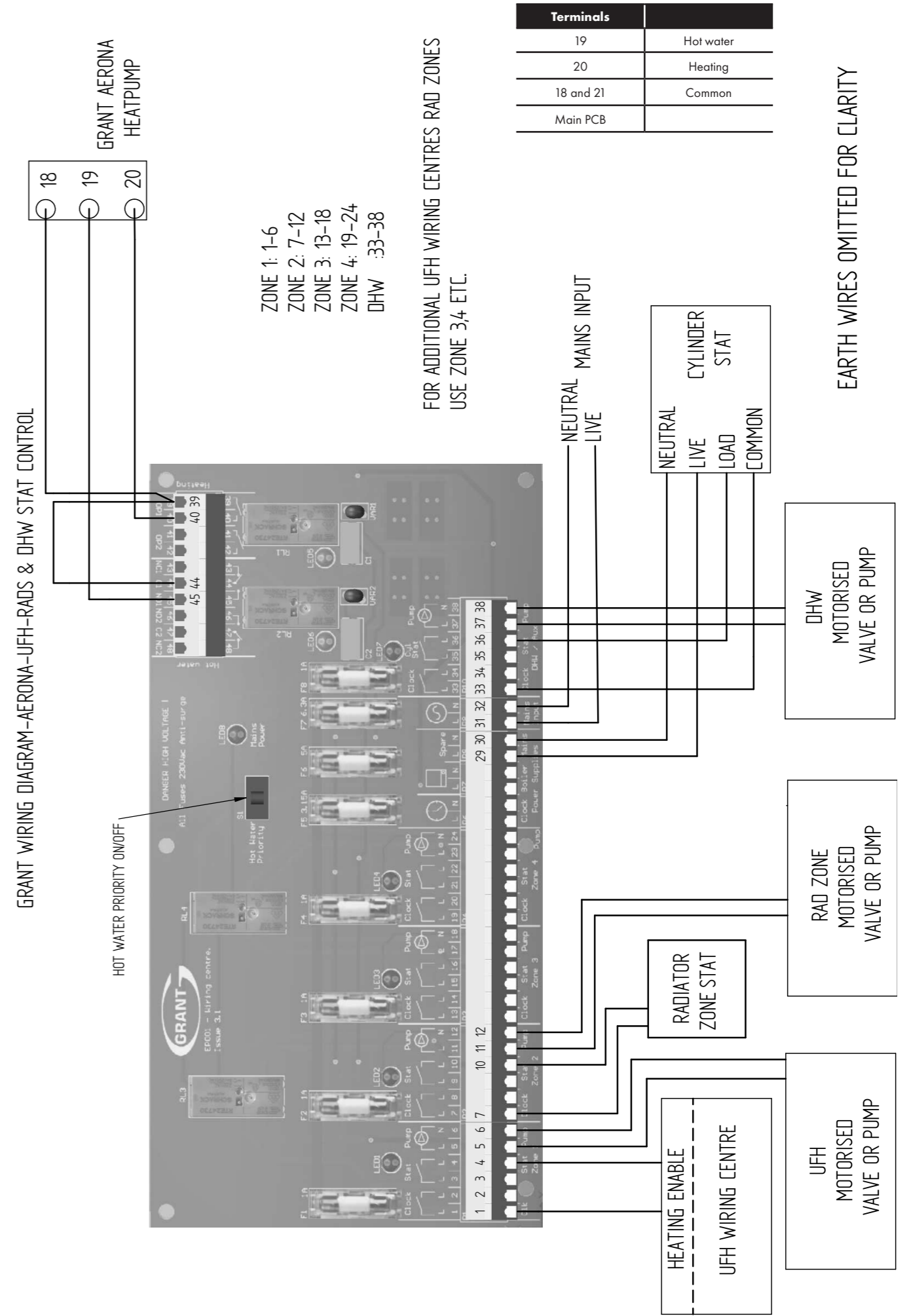

Figure 6-9: Wiring Centre - ufh & rads

GRANT WIRING DIAGRAM-AERONA-RADS & DHW

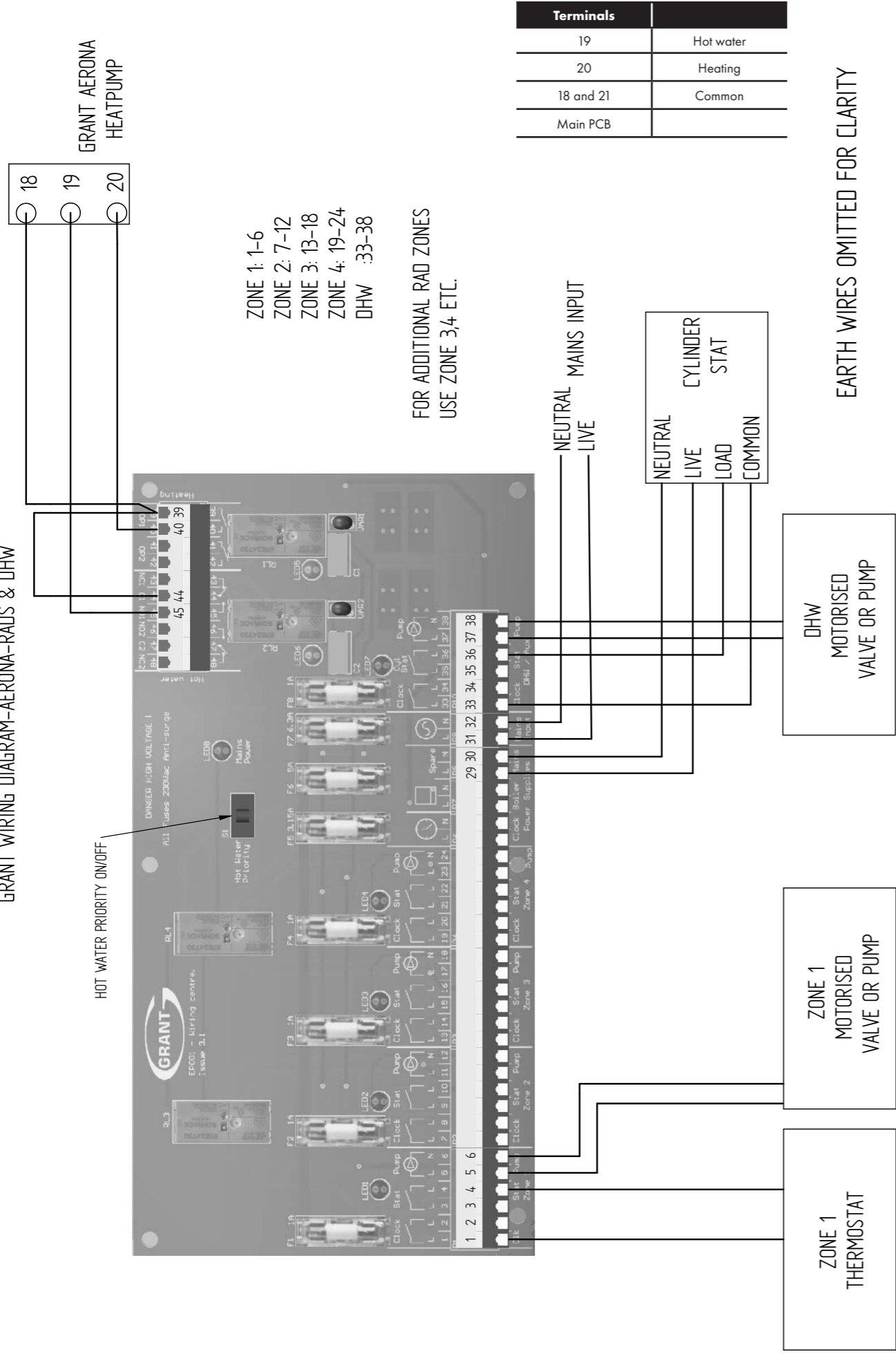

Figure 6-10: Wiring Centre- rads only

GRANT WIRING DIAGRAM-AERONA-TIME-CLOCK-CONTROL-RADS & DHW

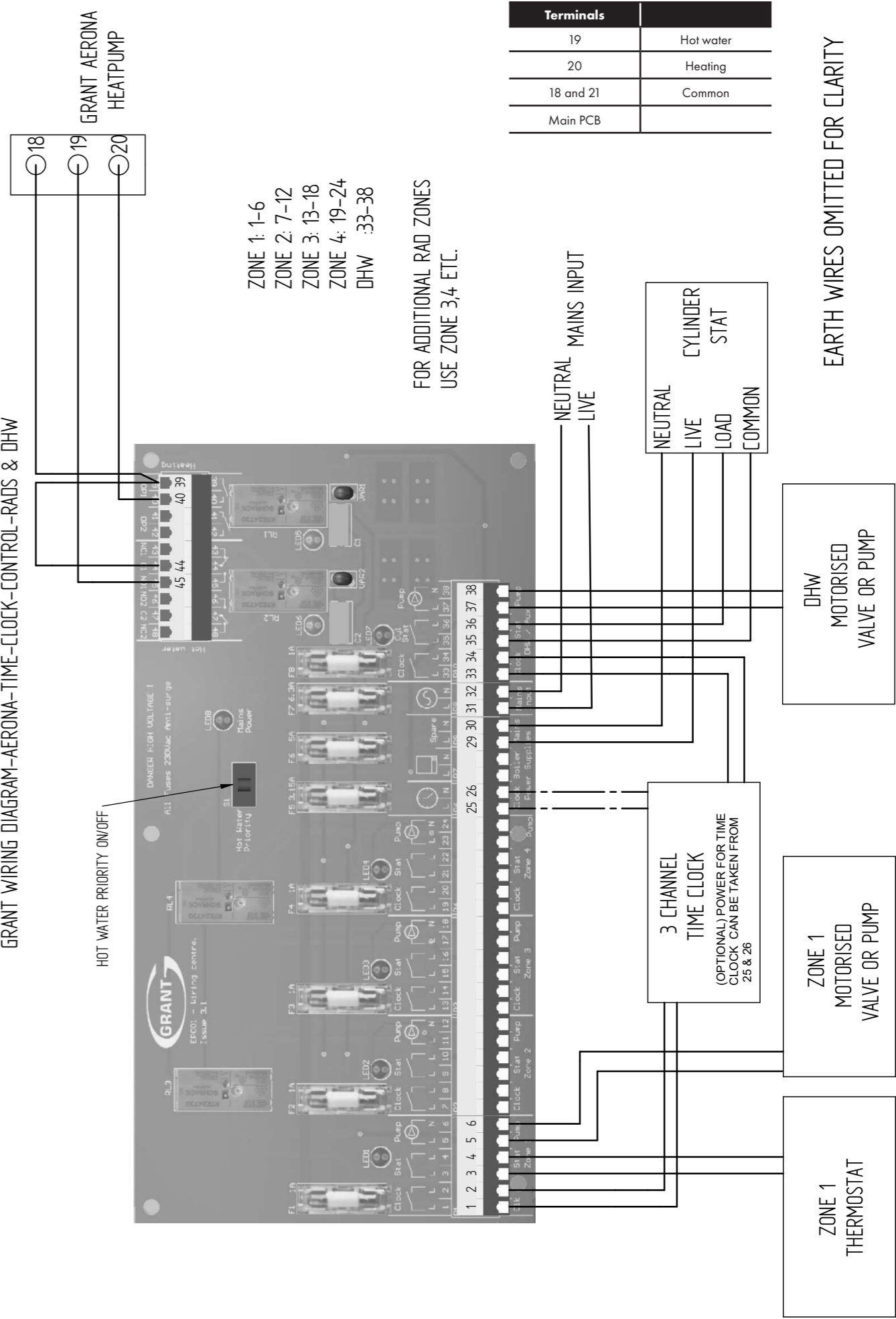

Figure 6-10: Wiring Centre- time clock control rads



# 7 REMOTE CONTROLLER

## 7.1 Remote Controller

The remote controller is used to:

- switch the heat pump on and off
- display room temperature
- display outdoor temperature
- display day/time (refer to Section 9.2 for setting the day and time)
- access and check/adjust remote controller parameters.
- to access and check/adjust the heat pump control parameters (refer to Section 9 and also Appendix A)

The remote controller will also display any fault error codes should there be a fault condition. Refer to Section 11.

It can also be used view the heat pump operating conditions at any point in time using the Monitor Display function. Refer to Section 10.7.

## 7.2 Installation Requirements

### Notes for the remote controller installation

The remote controller should be installed in a convenient position where the user can easily access it to view the display and operate the on/off switch when necessary.

It is a requirement of MCS installations that any fault indication (e.g. the fault error codes displayed on the remote controller screen) should be visible to the user.

- Do not install the remote controller in damp conditions such as in the bathroom. The remote controller is not waterproof.
- Never install above a cooker or boiler or any other combustion device. This would cause breakdown of electrical parts and deformation of the outer case.
- Do not install in any location subject to steam.
- Do not install in any location subject to direct sunlight.
- Install the remote controller a convenient position where it is out of the reach of children.
- The remote controller can be installed in the same room as underfloor heating.
- Do not install in any location where industrial chemicals are used (ammonia, sulphur, chlorine, ethylene compounds, acids, etc.).
- Route the remote controller cable in such a way that is not in contact with heat.
- Do not damage the remote controller cable and use cable conduit to avoid the damage.

**WARNING**

**The remote controller must NOT be fitted inside the heat pump casing.**

## 7.3 Installing the Remote Controller

- The connection between the heat pump and the remote controller is low-voltage, so it does not require electrical qualifications, but do follow technical standards for electrical equipment in making this installation.
- Isolate the main power supply to the heat pump before connecting the remote controller cable.

1. Slide the mounting plate downward to remove from the remote controller (refer to Figure 7-1).

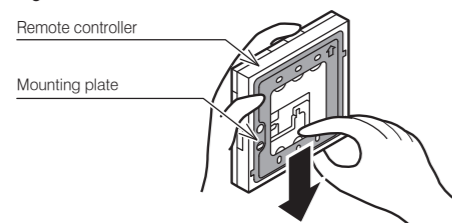

Figure 7-1: Removing the mounting plate

2. Fix the mounting plate to the wall.

### When the wiring is hidden

1. Before starting the remote controller installation, pass the wiring conduit through the inside of the wall (refer to Figure 7-2).
2. Pull out the Remote controller cable, passing it through the wiring conduit and through the wiring hole in the mounting plate.

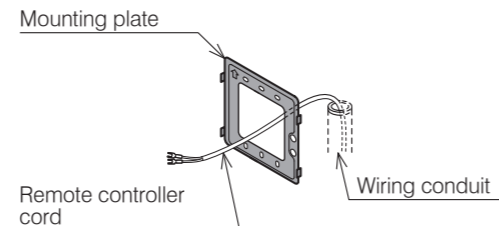

Figure 7-2: Wiring hidden

### When the wiring is exposed

1. Fix the mounting plate to a solid position on the wall with the two screws provided (refer to Figure 7-3).

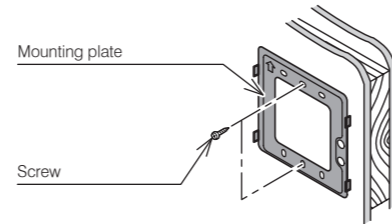

Figure 7-3: Wiring exposed

- Do not over tighten the screws as this can deform or break the screw hole of the mounting plate.
  - Use the wall plugs if the mounting plate is to be fixed by screws to tile, concrete or mortar.
  - The remote controller is connected using the two screw terminals on the rear of the controller. Refer to Figure 7-5.
3. Connect the remote controller cable to the terminal on the rear of the remote controller:
    1. Hook the wires under the clamp - locating it onto the four hooks
    - The remote controller has no polarity so wires can be connected either way round.
  4. Install the remote controller.
    1. Fix the remote controller to the mounting plate by sliding it downwards.
  5. After installing the remote controller, check the fixing is secure. If the mounting plate is not stable, tighten the screws further.

**WARNING**

**Do not use a power screwdriver. It can damage the screw hole which can cause contact failure.**

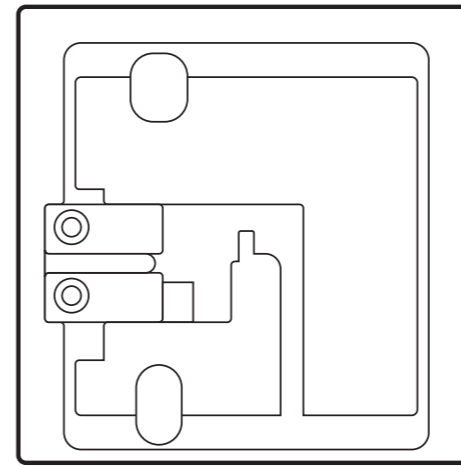
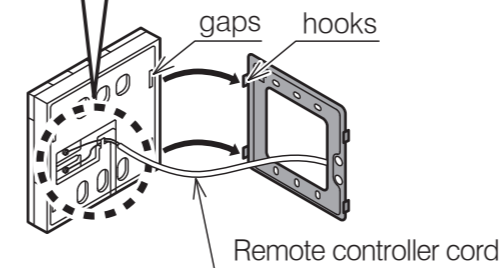
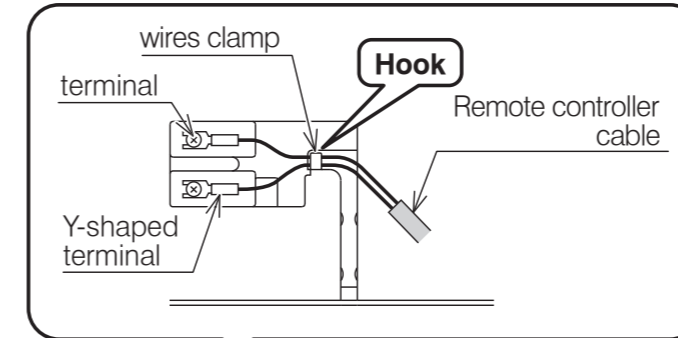

Figure 7-4: Remote controller (rear)

### When the wiring is embedded



### When the wiring is exposed

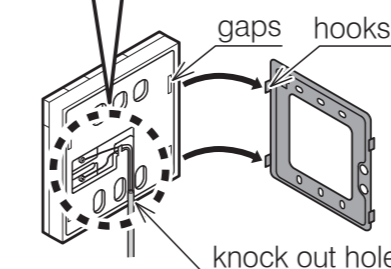
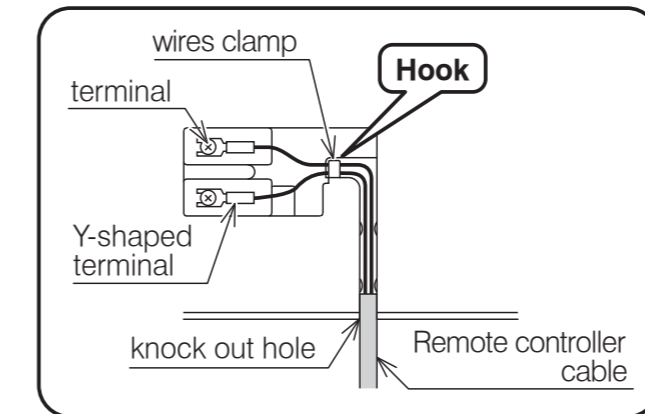

Figure 7-5: Connecting remote controller cable

## 7.4 Connecting the Remote Controller to the Heat Pump

1. Isolate the mains power supply for the heat pump from the power source.  
Do not connect the remote controller cable with the power on.
2. Remove the wiring cover.
3. Connect the remote controller cable to terminals 1 and 2 on the Terminal PCB. The remote controller has no polarity so it does not matter which wire of the remote controller cable is connected to + and -. Take care not to let your screwdriver etc. touch any of the other electronic parts. Do not use a power driver. It can damage the terminal screw holes.
4. If shielded wire is used, connect it to terminal 3 (GND) on the Terminal PCB.
5. Securely fasten the remote controller cable with the cord fastening fitting. Leave the display board waterproof cover removed.

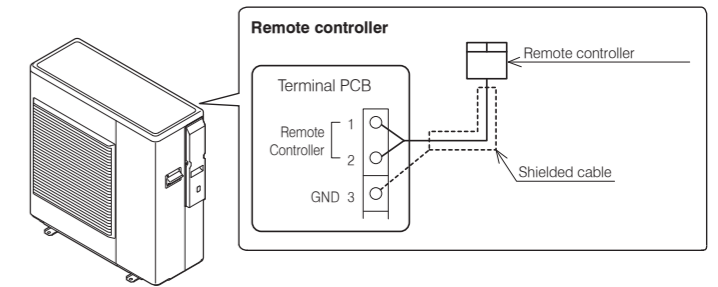

Figure 7-6: Connecting the remote controller to the heat pump

An 8 metre cable is supplied with the heat pump.

The maximum length of the remote controller cable is 100 metres.

Use shielded wire where the length is 30 metres or longer and connect the shielded wire to terminal 3 (GND) on the Terminal PCB.

Table 7-7: Remote controller cable

Distance	Cable (mm <sup>2</sup> )	Shield
~ 30 metres	Minimum 0.5	Non-shielded
30 ~ 100 metres	Minimum 1.0	Shielded

## 7.5 Buttons

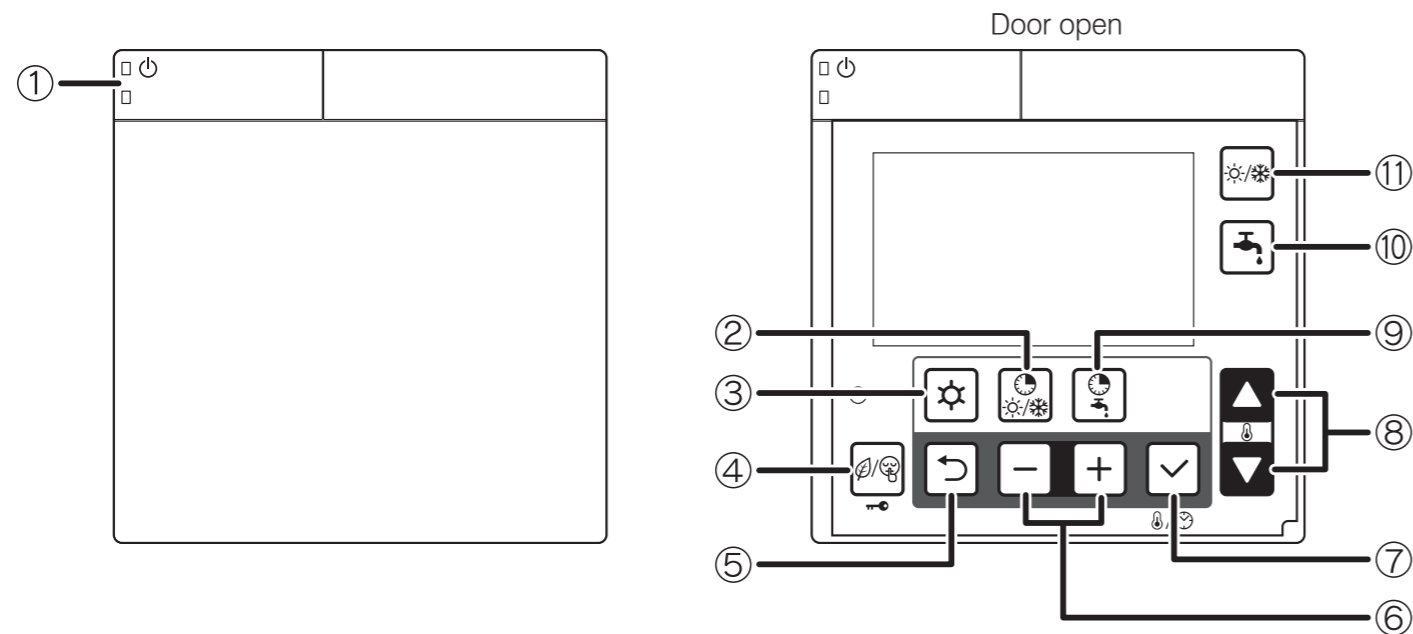

Figure 7-8: Remote controller (buttons)

Table 7-9: Remote controller (buttons)

No.	Button name	Description
1	ON/OFF	Push and hold the button for 3 seconds to turn ON and turn OFF the heat pump. The green LED on the ON/OFF button is lit when the heat pump is ON. The red LED on the ON/OFF button blinks when an error alarm on the heat pump occurs.
2	N/A	This button is reserved for future products - pressing this button will result in an audible 'beep' indicating no function.
3	Menu	Programming: dedicated button for accessing the menu/parameters. Push and hold the Menu button for 3 seconds to access the user level.
4	Timer for low tariff/night mode (key lock)	Refer to Sections 8.7 and 8.8 for details of low tariff/night mode operation. Push the Low tariff/Night button for 3 seconds to lock the button. When Key Lock is active, push 3 seconds to unlock. When key Lock is active, it is only possible to turn OFF the heat pump with the ON/OFF button. For low tariff/night mode function, an external timer must be connected.
5	Return	Return button in parameter programming mode. Push the Return button for 3 seconds to return to the normal display mode.
6	-,+	For parameter setting, select or return to the parameter group or code. Push the Menu,-,+ button together for 3 seconds to access the installer level. During error code display, push - and + button together for 3 seconds to reset display.
7	Set (confirm)	Push the Set button: -During the programming to save the setting. -Change display : Clock Room set temperature Time setting can be set by remote controller only Push the Set button for 3 seconds to set the current time (day, hour, minutes). Refer to Section 9 (Commissioning)
8	Up, down	For parameter setting, change the parameter group and code numbers. Please note: this is not to be used for setting the room temperature control.
9	N/A	This button is reserved for future products - pressing this button will result in an audible 'beep' indicating no function.
10	N/A	This button is reserved for future products - pressing this button will result in an audible 'beep' indicating no function.
11	N/A	This button is reserved for future products - pressing this button will result in an audible 'beep' indicating no function.

## 7.6 Display Panel

For guidance on the operation and setting of the remote controller, refer to Section 9 (Commissioning).

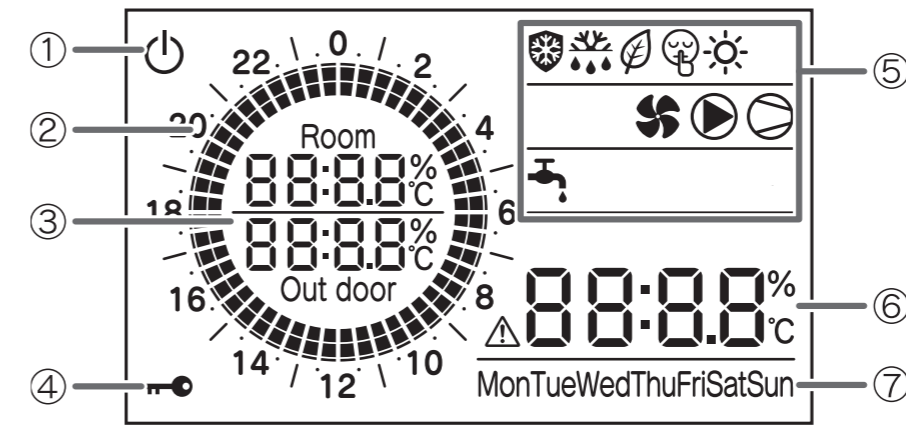

Figure 7-10: Remote controller (display panel)

Table 7-11: Display panel

No.	Icons	Description
1		Power is ON, but ON/OFF switch is OFF (the heat pump is stopped)
2		Indicates current time of day.
3		Room air temperature, Outdoor temperature
4		Key lock is active
5		Frost protection is active
		Defrost cycle is active
		Low tariff mode is enabled For low tariff mode, an external timer must be connected. Refer to Section 6.
		Night mode is enabled For night mode, an external timer must be connected. Refer to Section 6.
		When this symbol is lit, heating mode is enabled. When this symbol is flashing, the heat pump is in heating mode, however the heating is stopped for the production of DHW which has priority
		Heat pump fan is active
		System pump is active
		Compressor active Flashing: compressor delay
6		Indicates DHW demand On: demand
		Display alarm icon, and indicate error code Clock, Parameters value
7	MonTueWedThuFriSatSun	Day of the Week

Table 7-11: Back light display

Back light display	
ON	Door of remote controller open
OFF	Door of remote controller closed or Door of remote controller open but no operation of buttons for 60 seconds
	To adjust the back light operation, refer to Section 9.8.

# 8 OPERATION

## 8.1 Heat Pump Operation

The heat pump control is based on:

1. Outgoing water temperature (measured by outgoing water temperature sensor on heat pump)
2. Thermal store temperature

During heating operations, parameter 4100 is set to 1. The control of the heat pump is based on the outgoing water temperature.

The operation by water temperature can be "outgoing water temperature" or "thermal store temperature". If parameter 5111 is set to "enable" for thermal store temperature sensor. In this case the operation will be based on thermal store temperature.

Set the parameter correctly for enable/disable of thermal store (parameter 5111), the main water pump setting (parameter 4200). Refer to Table 8-1.

**Table 8-1:** Parameters

	Parameter 5111 thermal store temperature	Parameter 4100 heat pump ON/OFF	Parameter 4200 main water pump
Outgoing water temperature	0=disable	1=Water set point	0=always ON 2=detect cycle
Thermal store temperature	1=enable	0=room set point	0=always ON 1=thermal store temperature 2=detect cycle

For further information, refer to Section 3.8 (volumiser tanks).

### 8.1.1 Heat Pump controlled based on Outgoing Water Temperature

Based on the outgoing water temperature setting, the compressor is controlled and turned ON/OFF.

#### Start of Operation

When the outgoing water temperature is below the water set point, the heat pump is turned ON.

Heating : Outgoing water temp  $\geq$  Water set point (parameter 2100~2105) – Hysteresis (parameter 2141)

#### Compressor Control

The compressor is controlled so that the Outgoing water temperature can reach the water set point.

#### When the water setpoint temperature is reached, compressor is stopped

With the minimum compressor frequency, if the Outgoing water temperature is in the following conditions, or if the Outgoing water temperature reaches the water set point to protect heat pump, then compressor shall be turned OFF.

Heating : Outgoing water temp.  $\geq$  Water set point (parameter 2100~2115) +1°C

Outgoing water temp.  $\geq$  60.5°C

#### Compressor OFF ON control

When the Outgoing water temperature reaches the set point and after

**Table 8-2:** Parameters

Level	Parameter		Function description	Display and input value				Remarks
	Group	Code		Default	Min.	Max.	Unit	
1	41	00	The heat pump turns ON/OFF based on 1=water set point	1	0	1	-	To be set to the following combinations parameter 5111=0 Parameter 4200=0 or 2 parameter 5111=1 Parameter 4200=0 or 1 or 2
1	42	00	Type of configuration of main water pump 0=always ON 1=ON/OFF based on buffer tank temperature 2=ON/OFF based on detect cycles	0	0	2	-	
1	51	11	Terminal 11-12: thermal store temperature probe 0=disable 1=enable	0	0	1	-	

For details of how to access the parameter settings, refer to Section 9.3.

the compressor is turned OFF, or when the conditions below are met, the compressor shall be turned ON.

However, the compressor is not turned ON during 3 minutes OFF-ON waiting time.

### 8.1.2 Heat Pump controlled based on Thermal Store Temperature

In order to reach the thermal store set point, compressor frequency shall be controlled so that outgoing water temperature can reach the maximum temperature in Heating mode (60°C) And, the compressor is turned ON/OFF based on thermal store set point also being reached.

#### Start of Operation

When the Outgoing water temperature does not reach the water set point, heat pump is turned ON.

#### Compressor Control

The compressor is controlled to reach the maximum flow temperature in Heating mode (60°C).

#### When the water set point is reached, compressor is stopped

The compressor shall be turned OFF if the thermal store set point is reached, or if the Outgoing water temperature is in the following conditions, or the Outgoing water temperature reaches the set point to protect heat pump.

Heating: thermal store temperature  $\geq$  thermal store set point (parameter 2161)

Outgoing water temp.  $\geq$  Maximum Outgoing water set point (60°C) +1°C

Outgoing water temp.  $\geq$  62.5°C

#### Compressor OFF ON control

When the thermal store temperature reaches the set point, or when the conditions below are met after the compressor is turned OFF due to the set point protecting the heat pump, the compressor is turned ON.

However, the compressor is not turned ON during 3 minutes OFF-ON waiting time.

Heating: thermal store temp.  $\leq$  thermal store set point (parameter 2161) – Hysteresis (Parameter 2141)

Outgoing water temp.  $\leq$  Water set point (60°C) – Hysteresis (parameter 2141)

Outgoing water temp.  $\leq$  57.5°C

Based on Water Temperature

## Heating mode

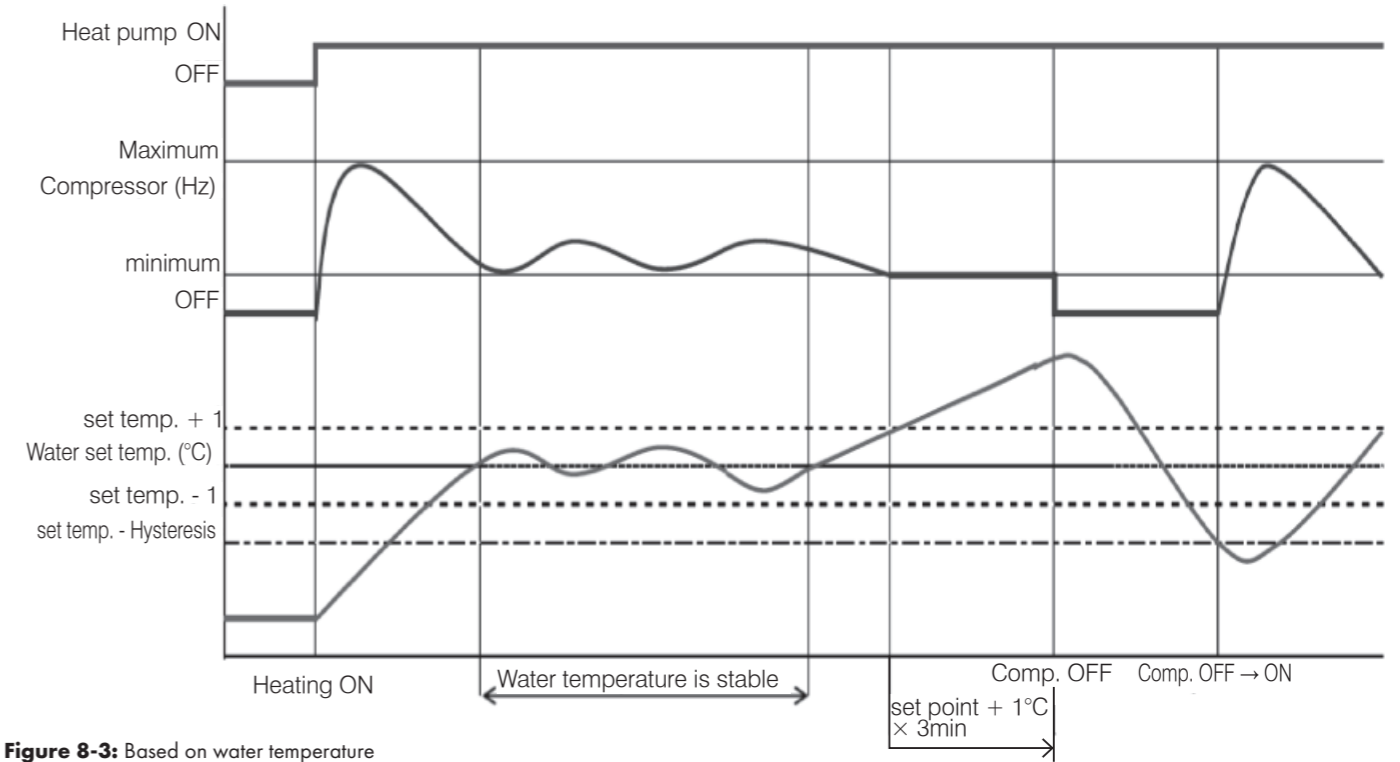

**Figure 8-3:** Based on water temperature

## 8.2 Weather Compensation

### 8.2.1 Water Temperature Control Point

The water temperature control point is based on a variable set point calculated automatically using climatic (weather compensation) curves as described below.

### 8.2.2 Heating Climatic Curves

The regulation of the temperature of the outlet water from the heat pump, in normal winter heating operation, is based on the climatic curves.

The basic logic is to modulate the temperature of the outlet water depending on the outdoor air temperature.

**During commissioning, the four climatic curve parameters must be checked and the default values adjusted to suit the design parameters for the system in question.**

For example:

Maximum outgoing (flow) temperature in heating mode (Tm1) – Parameter 2102, must be set to the design maximum flow temperature for the system.

Minimum outdoor air temperature (Te1) – Parameter 2104, must be set to the same value as used in the design heat loss calculations for the building.

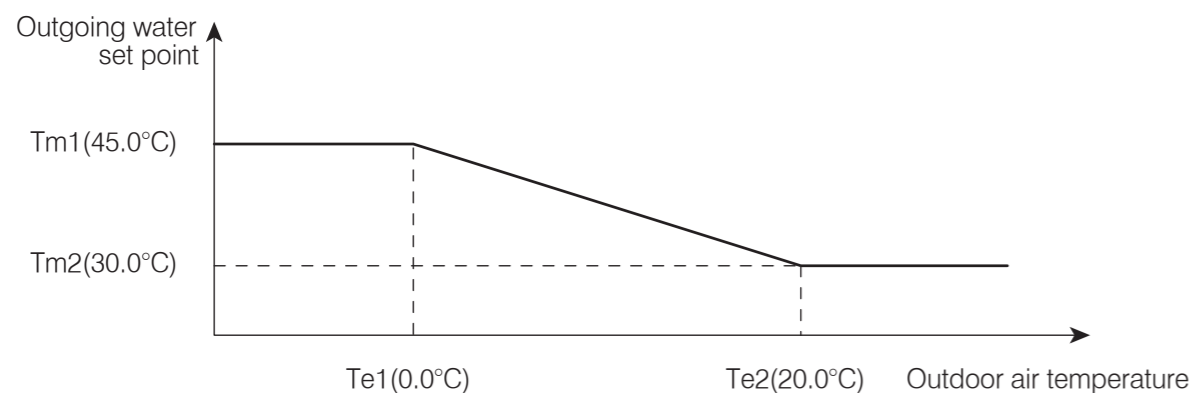

Figure 8-4: Climatic curves

Table 8-5: Outgoing water temperature parameters

Level	Parameter		Function description	Display and input value				Remarks
	Group	Code		Default	Min.	Max.	Unit	
I	21	00	Enable outgoing water set point 0=fixed set point* 1=climatic curve	1	0	1	-	
I	21	01	Fixed outgoing water set point*	45.0	23.0	60.0	0.5°C	
I	21	02	Maximum outgoing water temperature in Heating mode (Tm1)	45.0	23.0	60.0	0.5°C	
I	21	03	Minimum outgoing water temperature in Heating mode (Tm2)	30.0	23.0	60.0	0.5°C	
I	21	04	Minimum outdoor air temperature corresponding to maximum outgoing water temperature (Te1)	-4	-20.0	50.0	0.5°C	
I	21	05	Maximum outdoor air temperature corresponding to maximum outgoing water temperature (Te2)	20.0	0.0	40.0	0.5°C	
I	21	41	Hysteresis of water set point in heating	8.0	0.5	10.0	0.5°C	

\* Fixed set point - thermal store require temperature sensor

For details of how to access the parameter settings, refer to Section 9.3.

### 8.2.3 Fixed Set Point

The heat pump is supplied with parameter 2100 set to a default setting of 1 (Climatic curve operation).

For the heat pump to operate based on a fixed outgoing water set point parameter 2100 must be reset to 0 (fixed set point).

With parameter 2100 set to 0, the outgoing water fixed set point is determined by parameter 2101 (factory default value = 45°C).

To stop operation of the weather compensation function, and set the outgoing water temperature control to 'fixed set point', set Parameter 2100 to 0 and parameter 2101 to the required 'fixed set point' value.

## 8.3 Water Pump Management

### 8.3.1 Main water pump

Fundamentally, the ON/OFF of the main water pump links to ON/OFF of the compressor, but the setting ON/OFF of the pump during compressor OFF states, due to reaching the room set point shall be set in the following parameters:

- Always ON, apart if any alarms are active or if the heat pump is in OFF mode
- ON/OFF based on thermal store temperature
- ON/OFF based on detect cycle

If the thermal store temperature probe is enabled, the main water pump turns ON if the thermal store temperature is lower than outgoing water set point (fixed or calculated by climatic curve) – hysteresis, in heating mode. When the thermal store temperature reached the set point (fixed or calculated by climatic curve), the main pump turns OFF.

### 8.3.2 Continuous operation "Always ON"

When the heat pump is set to "heating" (i.e. not in standby) the main water pump will always remain ON.

When the heat pump is set to standby, the pump will remain OFF and will only be started in the conditions described in paragraph in Section 8.3 (Frost protection).

### 8.3.3 Detect operation "Detect cycle"

In order to minimise energy consumption, the main water pump can be configured to start only when there is demand from the temperature controller.

The pump will be activated periodically, for a time set by parameter. Five seconds before the cycle ends, if the outgoing water temperature is lower than "water set point – hysteresis", the compressor will be activated and the pump will remain ON. When the compressor stops, the pump will continue running for a time set by parameter, after which it will be switched OFF and will repeat the detect cycles.

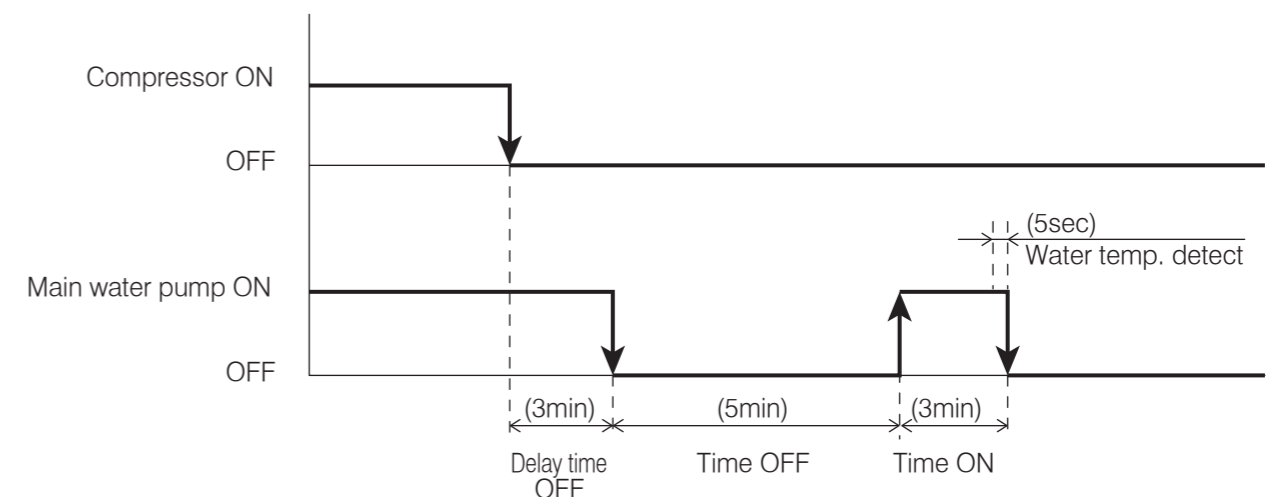

Figure 8-6: Detect cycle

Table 8-7: Detect cycle parameters

Level	Parameter		Function description	Display and input value				Remarks
	Group	Code		Default	Min.	Max.	Unit	
I	42	00	Type of configuration of Main water pump 0=always ON 1=ON/OFF based on thermal store temperature 2=ON/OFF based on Detect	0	0	2	-	To be set to the following combinations Parameter 5111=0 Parameter 4200=0 or 2 Parameter 5111=1 Parameter 4200=0 or 1 or 2
I	42	01	Time ON main water pump for detect cycle	3	1	15	1 min	
I	42	02	Time OFF main water pump	5	5	30	1 min	
I	42	03	Delay time OFF main water pump from OFF compressor	3	1	15	1 min	
I	51	11	Terminal 11-12 : thermal store temperature probe 0=disable 1=enable	0	0	1	-	

For details of how to access the parameter settings, refer to Section 9.3.

The interval between one detect cycle and the next is set by a parameter.

Refer to Figure 8-6 (detect cycle).

### 8.3.4 Warm Weather Operation



**The 'detect cycle' is allowed only for space heating. If the heat pump is working to produce DHW the main water pump has to run continuously.**

At ambient temperatures exceeding the maximum outdoor air temperature setting (Te2) – Parameter 2105, the weather compensation function will not allow the heat pump to operate to provide space heating.

**To override this and force the operation of the heat pump (e.g. to check operation or commission the heat pump) parameter 2100 must be set to 0. With this setting the heat pump will operate at a fixed set point of 45°C irrespective of the outdoor air temperature.**

If the weather compensation function is required, Parameter 2100 must be reset to 1 once the heat pump has been commissioned or its operation checked.

### 8.3.5 Unblock pump function

When the heat pump is stopped for more than 48 hours (parameter 4211), the water pump turns ON for 5 seconds (parameter 4212) to prevent seizing up and increases the life time of the pump.

In the case of the main pump and the additional pump, the down time after the previous operation stop is counted individually. Furthermore, the pump operation time can be set individually to prevent seizing.

Level	Parameter		Function description	Display and input value				Remarks
	Group	Code		Default	Min.	Max.	Unit	
I	42	11	OFF time for unblock pump function start	48	0	240	1 hr	
I	42	12	Time ON main water pump for unblock pump function	5	0	10	1 sec	

**Table 8-8:** Unblock pump function parameters

### 8.3.6 Pump output adjustment function

Adjust the main water pump output so that the required flow rate is produced in the heating system.

Using the DIP SW on the Terminal PCB, three level settings are possible.

**NOTE**  
An excessively low flow rate may cause problems including reduced capacity and poor circulation.

To select one of the three performance curves, set DIP SW5 and DIP SW6 as shown in Figure 8-9.

Factory default setting:  
DIP SW5 and DIP SW6 set to OFF (level 3)

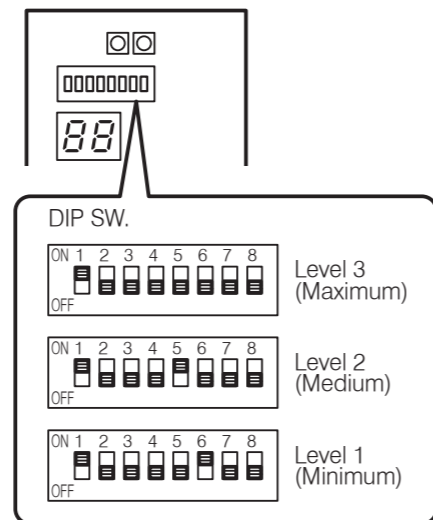

**Figure 8-9:** Pump output adjustment flow rate - DIP switches

### HPID6

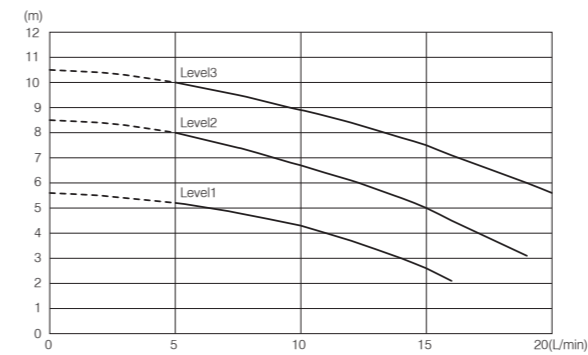

**Figure 8-10:** Pump output adjustment flow rate - HPID6

### HPID10

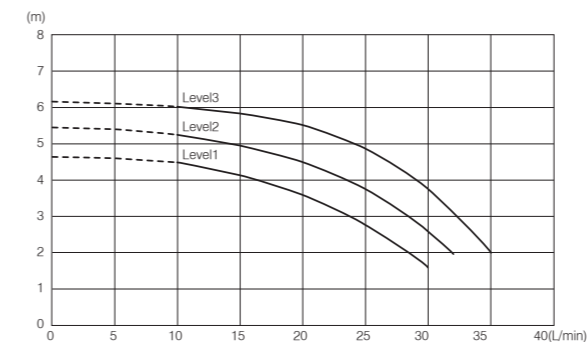

**Figure 8-11:** Pump output adjustment flow rate - HPID10

### HPID16

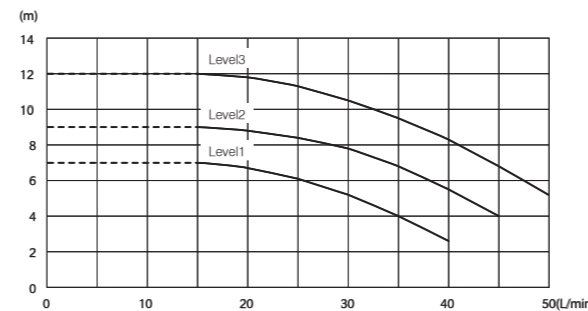

**Figure 8-12:** Pump output adjustment flow rate - HPID16

**CAUTION**  
The water flow rate must be sufficient to achieve an 8K difference between the flow and return water temperatures.

### 8.3.7 Additional water pump

Parameter 5148 can be utilised to use an additional water pump.

Parameter 4220 can be used to set the desired type of pump operation as follows:

1. Depending on main water pump setting
2. Depending on main water pump setting but always OFF when DHW mode is activated
3. Always ON apart from if any alarms are active or if the heat pump is in OFF mode

Option 2 is recommended for the majority of applications.

The connection between neutral and terminal 48 (Pump1) is ULC to 1 amp, therefore a relay must be installed if an additional water pump is used. Refer to Figure 8-13.

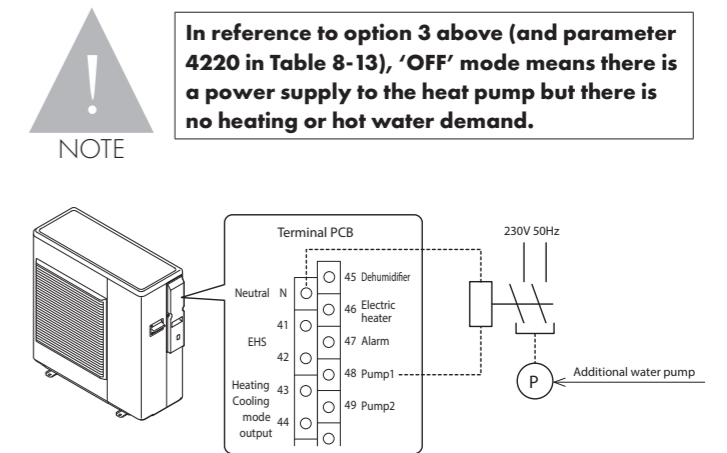

**Figure 8-13:** Additional water pump

**Table 8-14:** Additional water pump parameters

Level	Parameter		Function description	Display and input value				Remarks
	Group	Code		Default	Min.	Max.	Unit	
I	51	48	Terminal 48 0=disable 1=additional water pump	0	0	1	-	
I	42	20	Type of operation of additional water pump 0=disable 1=depending on main water pump setting 2=depending on main water pump setting but always OFF when the DHW mode is activated 3=always ON, apart from if any alarms are activated or if the heat pump is in OFF mode	0	0	3	-	

For details of how to access the parameter settings, refer to Section 9.3.

## 8.4 Frost Protection

Frost protection can be activated when the heat pump is in OFF mode.

This is based on either:

- Outdoor air temperature - refer to Section 8.4.1 and Figure 8-16.
- Flow water temperature - refer to Section 8.4.2 and Figure 8-17.
- Room air temperature - refer to Section 8.4.3 and Figure 8-18.

This function is not required if ethylene glycol (heating system antifreeze) is used in the heating system water. Refer to Section 3.10.3 for guidance on how to switch off the frost protection function.

### 8.4.1 Frost Protection based on Outdoor Air Temperature

This frost protection function is always active, even when the heat pump is not operating (but the mains supply is switched on).

The water pump is activated if the outdoor air temperature (measured by the heat pump outdoor temperature sensor) is less than the start temperature - parameter 4311 (default: 4°C).

It is deactivated when the outdoor air temperature reaches 'outdoor air temperature set point + Hysteresis' - parameter 4311 plus the hysteresis parameter 4312 (default: 7°C).

The 'frost protection' symbol (❄️) will be displayed on the remote controller screen when this frost protection function is in operation.

Under low ambient air conditions the water pump may operate for an extended period to provide frost protection when the heat pump is not operating, e.g. possibly throughout the night, until the heat pump starts the following morning.

Whilst the water pump may operate for long periods, when the prevailing conditions dictate, the cost to protect the heat pump from freezing is small due to the low water pump power consumption.

### 8.4.2 Frost Protection based on Flow Water Temperature

This frost protection function is always active, even when the heat pump is not operating (but the mains supply is switched on).

The water pump is activated if the flow water temperature is less than the start temperature - parameter 4321 (default 4°C).

It is deactivated when the flow water temperature reaches 'flow water temperature set point (parameter 4321) + hysteresis - parameter 4322 (default 3°C)'.  
(default 3°C).

The 'frost protection' symbol (❄️) will be displayed on the remote controller screen when this frost protection function is in operation.

Under low ambient air conditions the water pump may operate for an extended period to provide frost protection when the heat pump is not operating, e.g. possibly throughout the night, until the heat pump starts the following morning.

Whilst the water pump may operate for long periods, when the prevailing conditions dictate, the cost to protect the heat pump from freezing is small due to the low water pump power consumption.

### 8.4.3 Frost Protection based on Room Air Temperature

This frost protection function is always active, even when the heat pump is not operating (but the mains supply is switched on).

The water pump is activated if the room air temperature (measured by the heat pump remote controller) is less than the start temperature - parameter 4301 (default: 14°C).

It is deactivated when the room air temperature reaches 'room air temperature set point + Hysteresis' - parameter 4301 plus the hysteresis parameter 4302 (default: 1°C).

The 'frost protection' symbol (❄️) will be displayed on the remote controller screen when this frost protection function is in operation.

Under low room air conditions the water pump may operate for an extended period to provide frost protection when the heat pump is not operating, e.g. possibly throughout the night, until the heat pump starts the following morning.

Whilst the water pump may operate for long periods, when the prevailing conditions dictate, the cost to protect the heat pump from freezing is small due to the low water pump power consumption.

Table 8-15: Frost protection parameters

Level	Parameter		Function description	Display and input value				Remarks
	Group	Code		Default	Min.	Max.	Unit	
I	43	01	Start temperature of frost protection on room air temperature	14.0	0.0	40.0	0.5°C	
I	43	02	Hysteresis of room air temperature of frost protection	1.0	0.5	5.0	0.5°C	
I	43	11	Start temperature of Frost protection on Outdoor air temperature	4.0	0.0	10.0	0.5°C	
I	43	12	Hysteresis of Outdoor air temperature	3.0	0.5	5.0	0.5°C	
I	43	14	Hysteresis of Flow water temperature	3.0	0.5	5.0	0.5°C	
I	43	21	Start temperature of Frost protection on Flow water temperature	4.0	0.0	10.0	0.5°C	
I	43	22	Hysteresis of Flow water temperature	3.0	0.5	5.0	0.5°C	

For details of how to access the parameter settings, refer to Section 9.3.

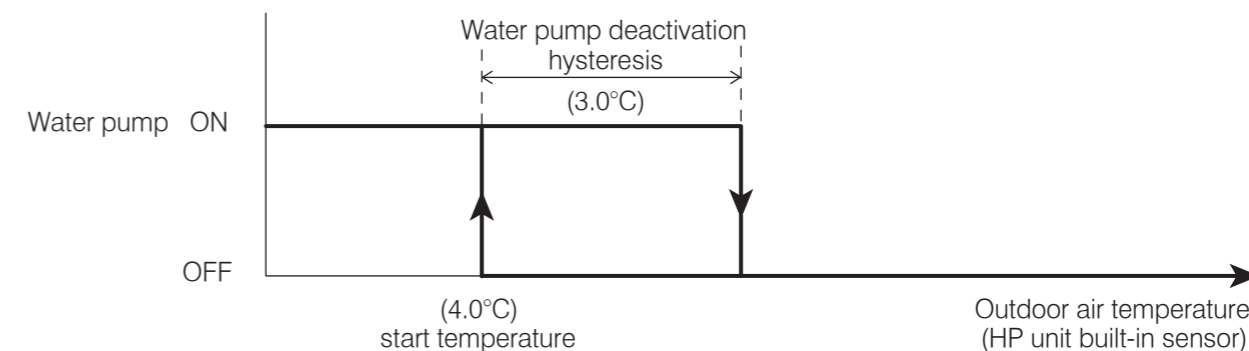

Figure 8-16: Frost protection (outdoor air temperature) - water pump

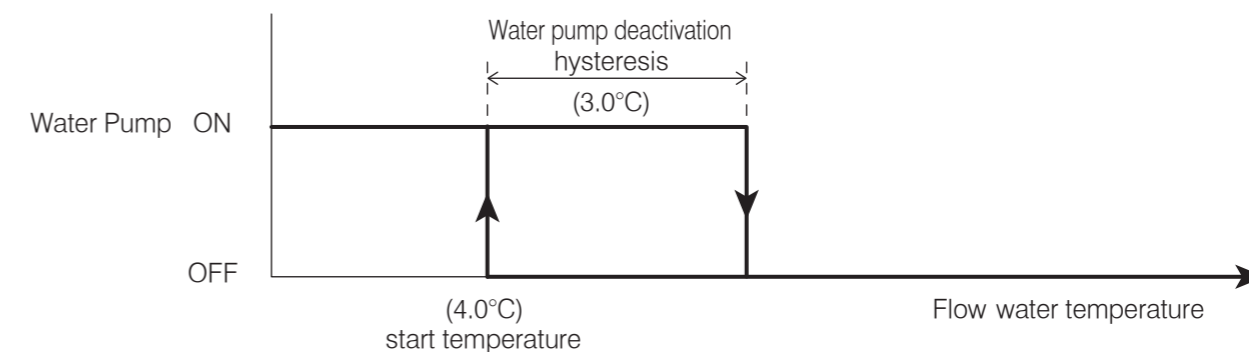

Figure 8-17: Frost protection (flow water temperature) - water pump

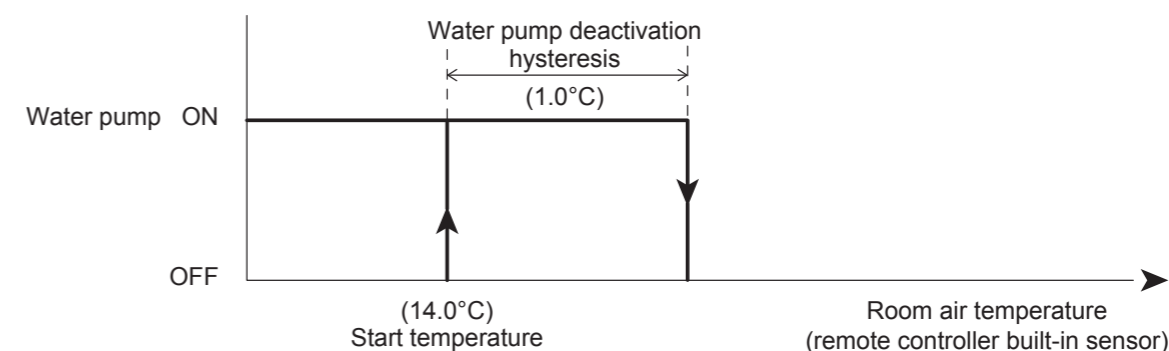

Figure 8-18: Frost protection (room air temperature) - water pump

### 8.5 ON/OFF DHW Production Remote Contact

The heat pump operation for DHW production is controlled from a remote contact, e.g. a cylinder thermostat or motorised valve switch.

The remote ON/OFF DHW contact is enabled by parameter 5119. Refer to Table 8-20. The DHW mode cannot be controlled automatically by the remote controller.

When DHW is turned ON by the remote contact and the heat pump is ON it will start operation in DHW (comfort) mode.

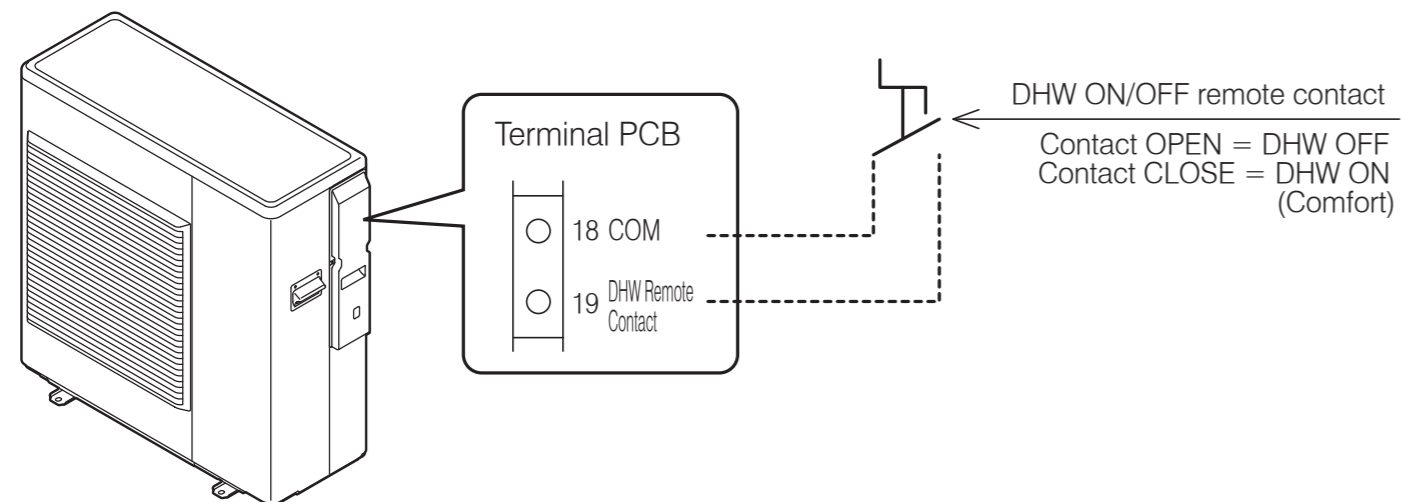

Figure 8-19: ON/OFF DHW production remote contact

**NOTE**  
In order to use DHW function, it is necessary to set parameter 3101=1 and parameter 5119=1.

**NOTE**  
Turn ON both remote controller using ON/OFF button, and DHW ON/OFF remote contact to start heat pump for DHW.

Table 8-20: DHW ON/OFF contact parameters

Level	Parameter		Function description	Display and input value				Remarks
	Group	Code		Default	Min.	Max.	Unit	
1	31	01	DHW production priority setting 0=DHW is unavailable 1= DHW is available, and priority DHW over space heating 2= DHW is available, and priority space Heating over DHW	1	0	2	-	
1	51	19	Terminal 19-18 : DHW remote contact 0=disable (Remote controller only) 1=enable	1	0	1	-	

For details of how to access the parameter settings, refer to Section 9.3.

### 8.6 ON/OFF Heating Remote Contact

The heat pump operation for heating is controlled from a remote contact, e.g. an external programmer, motorised valves and/or a room thermostat.

The ON/OFF heating contact is enabled by parameter 5120. Refer to Table 8-22.

The heating operation cannot be automatically controlled by the remote controller.

Heat pump will be turned ON/OFF according to remote contact.

For heating operation, both the remote controller and remote contact must be ON. If remote contact is turned OFF, then the heating will be turned OFF as well. Refer to Table 8-23.

If the remote controller is turned OFF, then the heat pump will be turned OFF.

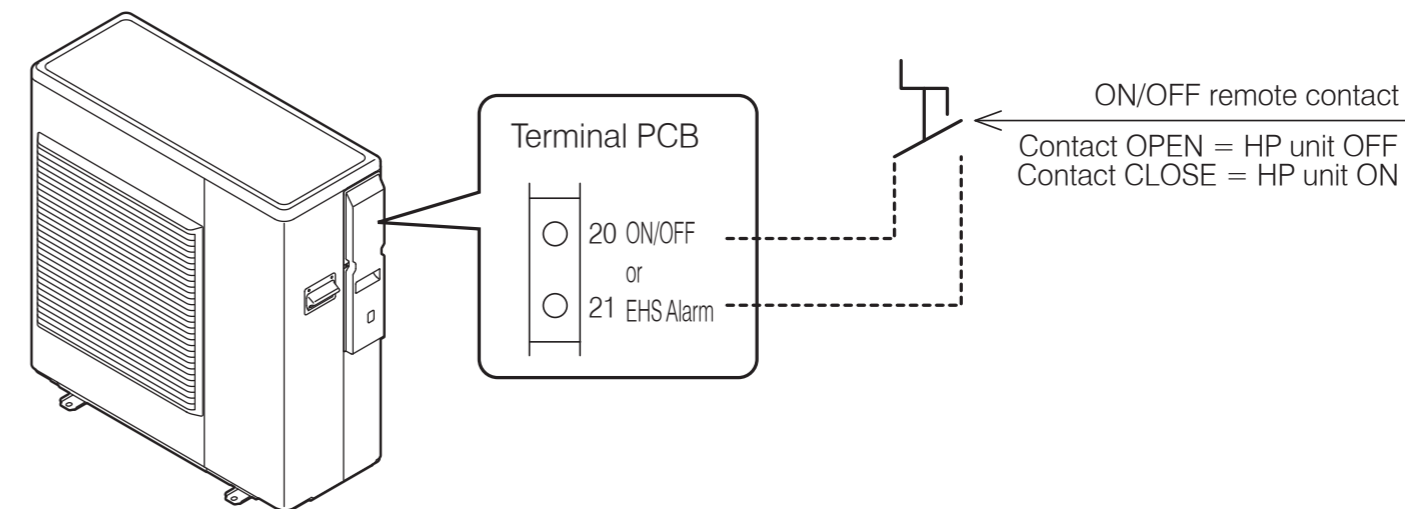

Figure 8-21: ON/OFF heating remote contact

Table 8-22: Heating ON/OFF contact parameters

Level	Parameter		Function description	Display and input value				Remarks
	Group	Code		Default	Min.	Max.	Unit	
1	51	20	Terminal 20-21 : ON/OFF remote contact input 0=disable (Remote controller only) 1=ON/OFF remote contact	1	0	2	-	ON/OFF by Remote controller 0=enable 1= On/Off enable 2= enable

For details of how to access the parameter settings, refer to Section 9.3.

Table 8-23: Remote controller / remote contact operation

Remote controller connected		Heat pump unit status	
Remote controller	Remote contact	Heat pump	Heating
ON	ON	ON	ON
ON	OFF	ON*	OFF
OFF	ON	OFF	OFF
OFF	OFF	OFF	OFF

\* Heat pump will be on standby or could be operating for DHW production

**NOTE**  
The frost protection is active even when the heat pump is switched OFF from the ON/OFF (heating) remote contact.

### 8.7 Night Mode

If there is a need to reduce the electricity consumption or noise produced by the compressor, e.g. in night-time operation, it is possible to activate the night mode function using an external contact, e.g. a timeswitch (with volt free contacts) connected between terminals 28-29 on the PCB terminal.

To enable these terminals, parameter 5128 must be set to 1. Refer to Table 8-25.

When the night mode function starts, according to the time setting, the maximum frequency will be decreased to the value selected on parameter 4111 in the ON time by time band setting (refer to Table 8-25). Otherwise it will operate in normal mode.

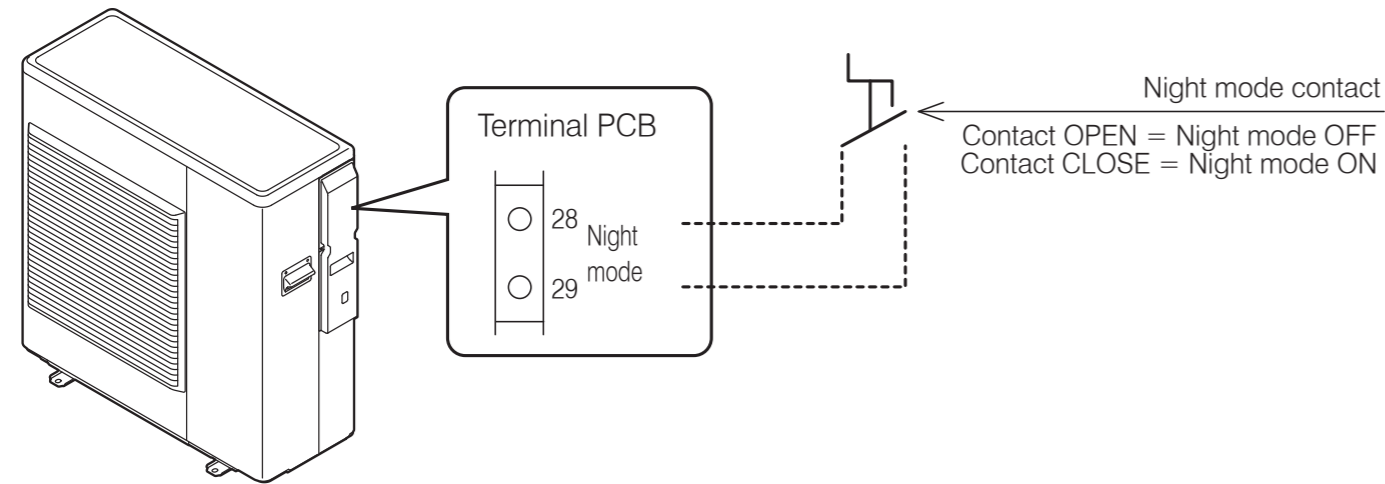

Figure 8-24: Night mode

**NOTE**

Parameter 5128 (night mode) and parameter 5130 (low tariff) are automatically synchronized to same value. If parameter 5128 is changed to 1 (enable), then parameter 5130 will be also changed to 1 (enable). With parameters 5128 and 5130 both set to 1 (enable), the night mode and low tariff function will operate independently of each other.

**NOTE**

During night mode with night mode contact ON, if parameter 5128 is changed to 0, the heat pump will continue to operate in night mode. During night mode by the remote controller button, if parameter 5128 is changed to 1, the heat pump will follow the signal of ON/OFF by night mode contact.

Table 8-25: Night mode parameters

Level	Parameter		Function description	Display and input value				Remarks
	Group	Code		Default	Min.	Max.	Unit	
I	51	28	Terminal 28-29 : Night mode 0=disable (Remote controller only) 1=enable	0	0	1	-	Parameter 5128 and parameter 5130 are synchronized in same value
I	41	11	Maximum frequency of Night mode	80	50	100	5%	

For details of how to access the parameter settings, refer to Section 9.3.

### 8.8 Low Tariff

The purpose of this function is to heat any thermal stores and DHW cylinders at a time when electricity rates are inexpensive.

This can be achieved by using an external contact, e.g. a timeswitch (with volt free contacts) connected between terminals 30-31 on the PCB terminal.

To enable these terminals, parameter 5130 must be set to 1. Refer to Table 8-27.

When low tariff function is activated the heating set point (calculated by the climatic curve) increases for heating (parameter 2151) by the low tariff differential water set point (refer to Table 8-27).

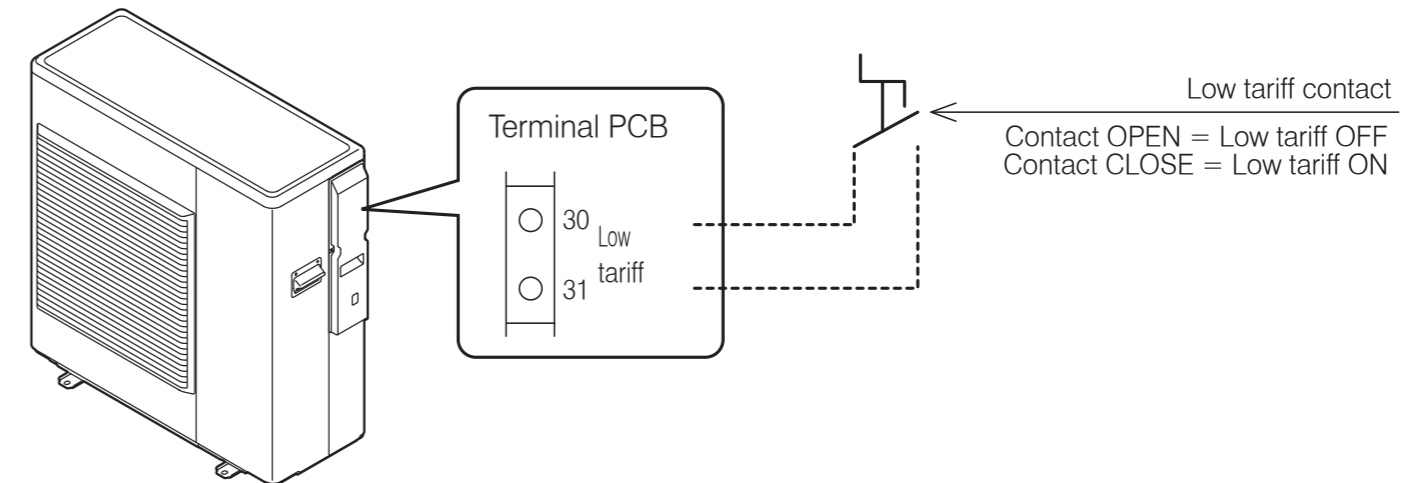

Figure 8-26: Low tariff mode

**NOTE**

Parameter 5128 (night mode) and parameter 5130 (low tariff) are automatically synchronized to same value. If parameter 5128 is changed to 1 (enable), then parameter 5130 will be also changed to 1 (enable).

**NOTE**

During low tariff with low tariff contact ON, if parameter 5130 is changed to 0, the heat pump will continue to operate in low tariff. During low tariff by the remote controller button, if parameter 5128 is changed to 1, the heat pump will follow the signal of ON/OFF by low tariff contact.

Table 8-27: Low tariff mode parameters

Level	Parameter		Function description	Display and input value				Remarks
	Group	Code		Default	Min.	Max.	Unit	
I	51	30	Terminal 30-31 : Low tariff 0=disable (Remote controller only) 1=enable	0	0	1	-	Parameter 5128 and parameter 5130 are synchronized in same value
I	21	51	Low tariff differential water set point for Heating	5.0	0.0	60.0	0.5°C	

For details of how to access the parameter settings, refer to Section 9.3.



# 9 COMMISSIONING

## 9.1 System Setup

The numbers in Figure 9-1 will be used for the system setup in this section.

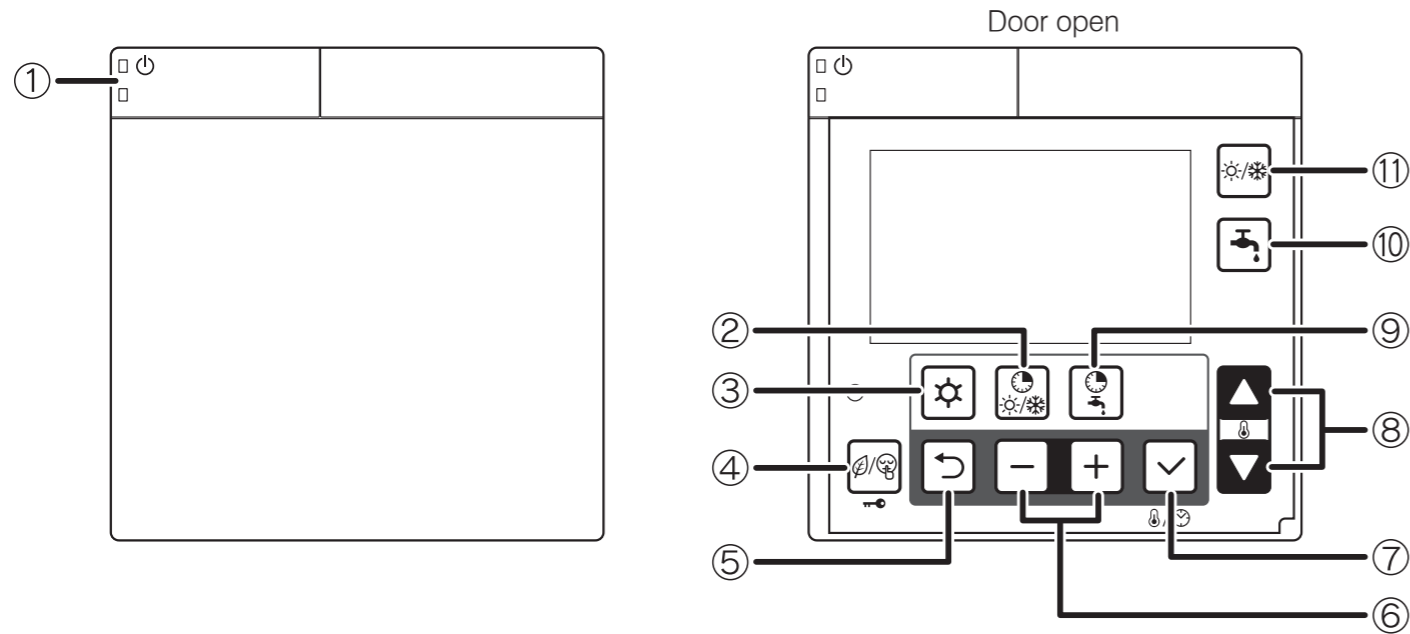



Figure 9-1: Remote controller buttons

### 9.1.1 Turning the Heat Pump On and Off

Press ON/OFF switch  for three seconds to turn the heat pump on or off. The green LED of ON/OFF switch is lit when the system is ON.



The heat pump will start in response to a demand for either heating or DHW.



NOTE

**The heat pump may take up to seven minutes after the demand as the heat pump will run the circulating pump and check the water temperature in the system before starting.**

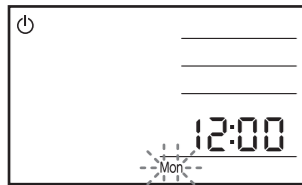

### 9.2 Setting the Day and Time

1. Press the Set button  for three seconds.
2. The day 'Mon' indicator will blink.  
Select the day by pressing the - or + buttons  and press set button  to save the setting.  
The day display stops blinking.

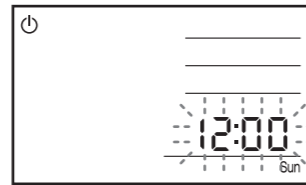

3. When the day of the week is set, 12:00 blinks; set the current time by pressing the - or + button.



When the - or + buttons  is pressed, the time changes in one minute increments; when the - or + buttons  is pressed and held, it changes in ten minute increments.

Press the Set button  to save the time setting. Then the display reverts to normal operation.

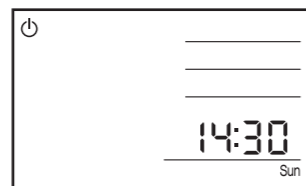

The accuracy of the clock is  $\pm 30$  second/month.

If there is a power cut, the day and time setting is maintained for approximately 24 hours. If the power cut continues over 24 hours, the day and time must be reset.

After installation and before setting the time or when the heat pump is reset after a power cut (lasting over 24 hours), the '12:00' and 'Mon' will blink, indicating that the time must be reset.

### 9.3 Access for Parameter Settings

The parameters are accessed and set using the remote controller.

There are two levels of access for parameter settings.













Access levels:

- U – End user level (accessible to user only)
- I – Installer Level (accessible to user and installer)

Refer to Sections 9.4 and 9.5 for how to access the above levels as there is a different procedure for each level.











### 9.4 Accessing the Parameter Setting Menu (User level)

The procedure for accessing, checking and setting the parameters is as follows:

1. Press the Menu button  on the remote controller for three seconds to enter the user level.
2. Parameter number "0000" and parameter value "----" will be shown on the display.
3. The first two digits of the 4-digit parameter number (the parameter group number) will blink.
4. Set the parameter group number, as required, using the Up or Down  buttons.
5. Press the - or + buttons  to switch to the parameter code and the second two digits will blink.
6. Set the parameter code number, as required, using the Up or Down  buttons.
7. Press Set  and the parameter value will be displayed.  
For 'read-only' items the number displayed remains on (not blinking) and pressing the Set button  does not affect the display.
8. If an invalid parameter (not accessible to the user) is entered and the Set button  pressed "----" is displayed. Press the Return button  to return to the parameter number.
9. If the parameter value can be adjusted it will blink.
10. Set the parameter to the required value using the Up or Down  buttons.
11. Press the Return  or Set  button. The parameter code number will blink to allow setting of another parameter, if required.
12. To return to normal operation, press and hold the Menu button  for three seconds, or simply leave the remote controller for ten minutes.

### 9.5 Accessing the Parameter Setting Menu (Installer level)





In the INSTALLER level more parameters can be accessed than in the USER level. The procedure for accessing, checking and setting the parameters is as follows:

1. Press the Menu  and the - and +  buttons on the remote controller simultaneously for three seconds to enter the installer level.
2. "InSt" parameter number "0000" and parameter value "----" will be shown on the display.
3. The first two digits of the 4-digit parameter number (the parameter group number) will blink.
4. Set the parameter group number, as required, using the Up or Down  buttons.
5. Press the - and +  buttons to switch to the parameter code and the second two digits will blink.
6. Set the parameter code number, as required, using the Up or Down  buttons.
7. Press Set  and the parameter value will be displayed and will blink.
8. Set the parameter to the required value using the Up or Down  buttons.
9. Press the Return  or Set  button. The parameter code number will blink to allow setting of another parameter, if required.
10. To return to normal operation, press and hold the Menu  and the - and +  buttons simultaneously for three seconds, or simply leave the remote controller for ten minutes.

### Master Reset (resetting all parameters to their defaults)

All parameters can be reset to their original defaults. The procedure is as

follows:



1. Press the Menu  and the - and +  buttons on the remote controller simultaneously for three seconds to enter the installer level.
2. Press and hold the low tariff/night mode (key lock)  button for ten seconds. All parameters will now be reset.
3. To return to normal operation, press and hold the Menu  and the - and +  buttons simultaneously for three seconds, or simply leave the remote controller for ten minutes.

### 9.6 Temperature Control – DHW function







The heat pump is supplied with a factory-set heat pump flow temperature for the DHW function and this is determined by the value of parameter 4130.

This temperature should be set to 55°C. This must be checked (by accessing parameter 4130) during commissioning, using the following procedure:







On the remote controller (refer to Section 9.1), first access the installer level:

1. Press and hold the Menu  , - and +  buttons together for 3 seconds to enter the installer level.
2. "InSt" parameter number "00 00" and parameter value "----" will be shown on the display. The first two digits of the parameter number will be blinking.

Then, access the service level:

1. Use the - or + buttons  to change these first two digits to 99 and then press the + button .
2. The second two digits will then blink. Use the - or + buttons  to change these two digits to 99 and then press the + button .
3. The parameter value on the display will now be '0'.
4. Use the - or + buttons  to change the parameter value to "738" and then press the Set .

Now, check parameter 4130:

1. The first two digits of the 4-digit parameter number (the parameter group number) will blink.
2. Set the parameter group number to 41 using the - or + buttons .
3. Press the + button  and the second two digits (the parameter code) will blink.
4. Set the parameter code number to 30 using the - or + buttons .
5. Press Set  and the parameter value (41 30) will be displayed and will blink.
6. Check that the value of parameter 41 30 is 55 (i.e. 55°C).
7. If NOT, set the parameter value to 55 using the - or + buttons .
8. Return to normal operation: Press and hold the Menu  , - and +  buttons together for 3 seconds or simply leave the remote controller for 10 minutes.

## 9.7 Parameters Input/Output

The following parameter settings must be checked on commissioning.

**Table 9-2:** Parameters input/output

Level	Parameter		Function description	Display and input value				Remarks
	Group	Code		Default	Min.	Max.	Unit	
I	51	19	Terminal 19-18 : DHW remote contact 0=disable (Remote controller only) 1=enable	1	0	1	-	
I	51	20	Terminal 20-21 : ON/OFF remote contact (CH) Alarm input 0=disable 1=ON/OFF remote contact	1	0	1	-	ON/OFF by Remote controller 0=enable 1=ON/disable OFF/enable 2=enable
I	51	28	Terminal 28-29 : Night mode* 0=disable 1=enable Refer to Section 8.6.	0	0	1	-	Parameter 5128 and Parameter 5130 are synchronised in same value
I	51	30	Terminal 30-31 : Low tariff* 0=disable 1=enable Refer to Section 8.7.	0	0	1	-	
I	51	46	Terminal 46 : DHW Electric heater or Backup heater 0=DHW Electric heater 1=Backup heater	0	0	1	-	

\* External timer required  
For details of how to access the parameter settings, refer to Section 9.3.

## 9.8 Remote Controller Back Light Display Parameters

The following parameters can be changed to adjust the back light display.

**Table 9-3:** Back light display parameters

Level	Parameter		Function description	Display and input value				Remarks
	Group	Code		Default	Min.	Max.	Unit	
U	02	03	Back light display at door open 0=OFF 1=ON	1	0	1	-	
U	02	04	Time to turn off the back light display	60	10	300	10 sec	
U	02	05	Time to back to normal display screen	120	10	300	10 sec	

For details of how to access the parameter settings, refer to Section 9.3.

## 9.9 Weather Compensation

During commissioning, the four climatic curve parameters MUST be checked and the default values adjusted to suit the design parameters for the system in question. Refer to Section 8.2.2 for details.

### Warm Weather Operation

**If, during commissioning, the ambient air temperature is higher than the air temperature setting (Te2) - parameter 2105 for the climatic curve, the weather compensation function will NOT allow the heat pump to operate to provide space heating.**

To override this and force operation of the heat pump (e.g. to check operation or commission the heat pump), parameter 2100 must be set to 0. The weather compensation will be switched off and the heat pump will operate at a fixed set point of 45°C irrespective of the outdoor air temperature.

If weather compensation is required, e.g. if the installation is to meet RHI requirements, parameter 2100 MUST be reset to 1 once the heat pump has been commissioned or the operation checked.

Alternatively, to operate the heat pump without touching the weather compensation settings, set the system controls to provide a hot water demand so that the heat pump operates to provide hot water heating. Reset the hot water controls to the normal setting once the heat pump has been commissioned or the operation checked.

## 9.10 Frost Protection Function Setting

Refer to Section 3.10.2 for details.

## 9.11 Pump Operation and Air Bleeding from Heating System

The circulating pump can be operated to aid removal of the air from the heating system.

To operate this function access the Terminal PCB.

- Check DIP SW4 is set to 'OFF'.



**Dip switch positions:**  
Up: ON  
Down: OFF

### NOTE

- Press the Pump SW. Refer to Figure 9-4.
- Wait for a few seconds. The pump will start and each of the six outer digital segments on the right-hand digit of the display on the terminal PCB will light up sequentially during pump operation.
- The pump stops automatically after 10 minutes of operation. If all the air could not be released from the water circuit, press Pump SW again (after the pump has stopped) to operate the pump for another 10 minutes.

If you want to stop the pump before it stops automatically, press Pump SW again.

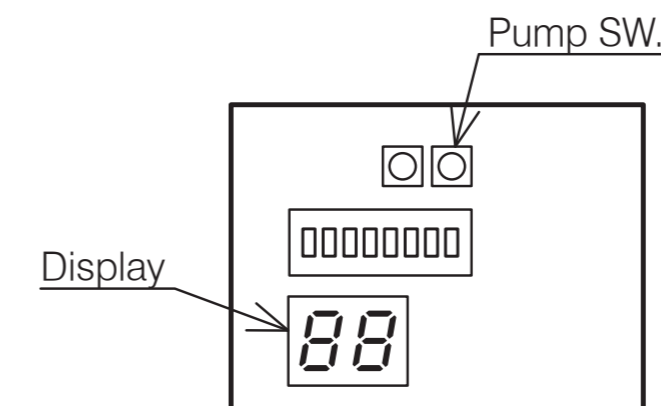

**Figure 9-4:** Water loading and air bleeding in the hydraulic circuit

## 9.12 Pump Output Setting

The water pump is supplied factory set to maximum output (level 3), i.e. with both DIP SW5 and DIP SW6 in the OFF position (down position). Refer to Figure 8-9.

As this pump performance may be too high for many systems, the water pump should be re-set to minimum (level 1) when commissioning the heat pump.

To do this, set DIP SW6 to ON (up position). Refer to Figure 8-9.

During commissioning, check that the required flow rate is produced in the heating system.

This will usually be indicated by achieving a temperature difference between the heat pump flow and return of approximately 8°C when the heating system is operating and up to temperature.

To determine the temperature difference, check the flow and return temperatures using the 'Monitor Display Function' on either the remote controller or Terminal PCB. Refer to Section 10.7 of these installation Instructions for details of how to check the flow and return water temperatures.

If necessary, the water pump output can be adjusted to achieve the required temperature difference between flow and return when the heat pump is operating.

The water pump can be set to the required output (e.g. level 1 or level 2) by resetting the position of either DIP SW5 or DIP SW6, as follows:

- For pump output level 2: Set DIP SW5 to ON (up position)
- For pump output level 1: Set DIP SW6 to ON (up position)

## 9.13 Coastal Installations

Alternatively if the Aeron3 heat pump is installed the evaporator must be sprayed with AFC50 and this repeated on each annual service. A blygold option is available for applications close to the coast, Blygold PoluAl is a metallic impregnated polyurethane coating specifically designed for application to aluminium finned-copper tube coils. It is a thin, flexible, UV and impact resistant coating that exhibits excellent adherence to aluminium surfaces.

# 10 SERVICING

## 10.1 General

Grant Aerona<sup>3</sup> Heat Pumps require only the minimum of routine servicing and maintenance.

This should be carried out on an annual basis and consist of the following:

### Heat pump - check:

- Visual condition of the heat pump
- Any debris/obstructions for the evaporator fins – remove if found
  - Remove by comb or foam based cleaner - do not attempt to do this manually
- The fan outlet is not obstructed - remove if found
- Condensate drain opening is clear
- Flexible hose condition
- Pipe insulation condition
- Remote controller settings
- That no refrigerant is leaking
- All electrical connections and PCB for scorching or dry cables
- If the Aerona<sup>3</sup> heat pump is installed within 15 miles of the coast, the evaporator must be sprayed with AFC50 and this repeated on each annual service.

### Heating system - check:

- Expansion vessel pressure
- Operation of pressure relief valve
- Heating system pressure – top up if necessary
- Correct concentration of corrosion/antifreeze protection
- Heating and hot water controls settings
- Any leaks on system
- For any sign of leakage from the refrigerant circuit - refer to Section 10.6.
- Magnetic filter is cleaned

### Master Reset (resetting all parameters to their defaults)

All parameters can be reset to their original defaults. The procedure is as follows:

1. Press the Menu | and the – and + O buttons on the remote controller simultaneously for three seconds to enter the installer level.
2. Press and hold the low tariff/night mode (key lock) m button for ten seconds. All parameters will now be reset.
3. To return to normal operation, press and hold the Menu | and the – and + O buttons simultaneously for three seconds, or simply leave the remote controller for ten minutes.

## 10.2 Air Inlet and Outlet

The air inlet grille and evaporator must be checked and leaves or any other debris removed from the space between the grille and the evaporator fins.



**Take care not to damage or distort the Aluminium fins of the evaporator when removing any debris.**

Ensure that both the air inlet to the evaporator and the discharge from the fan outlet are unobstructed. Any foliage, plants, etc. near the heat pump must not be allowed to grow over the heat pump.

Under no circumstances should anything be stacked on or against the heat pump.

Refer to Section 3.5.2 for the required clearances around the heat pump.

## 10.3 Condensate Disposal

Check that the condensate drain hole in the bottom of the heat pump is not blocked.

## 10.4 Heating System Connections

Check the condition of the flexible hoses. Replace if damaged or leaking.

## 10.5 Heat Pump Controls

Check that settings on the remote controller are as set when commissioned. Refer to settings given in the relevant sections of these instructions. Reset to commissioned settings if necessary.

## 10.6 Refrigerant

Under no circumstances should the refrigerant be vented from the charging points on the refrigerant circuit of the heat pump.

If any work is required to be carried out on the refrigerant circuit, it MUST be undertaken by an F-gas registered refrigeration engineer

On no account should any such work be carried out by unqualified personnel.

## 10.7 Monitor Display Function

The heat pump operating conditions, as listed in Table 10-3, can be displayed and checked on either the remote controller or Terminal PCB.

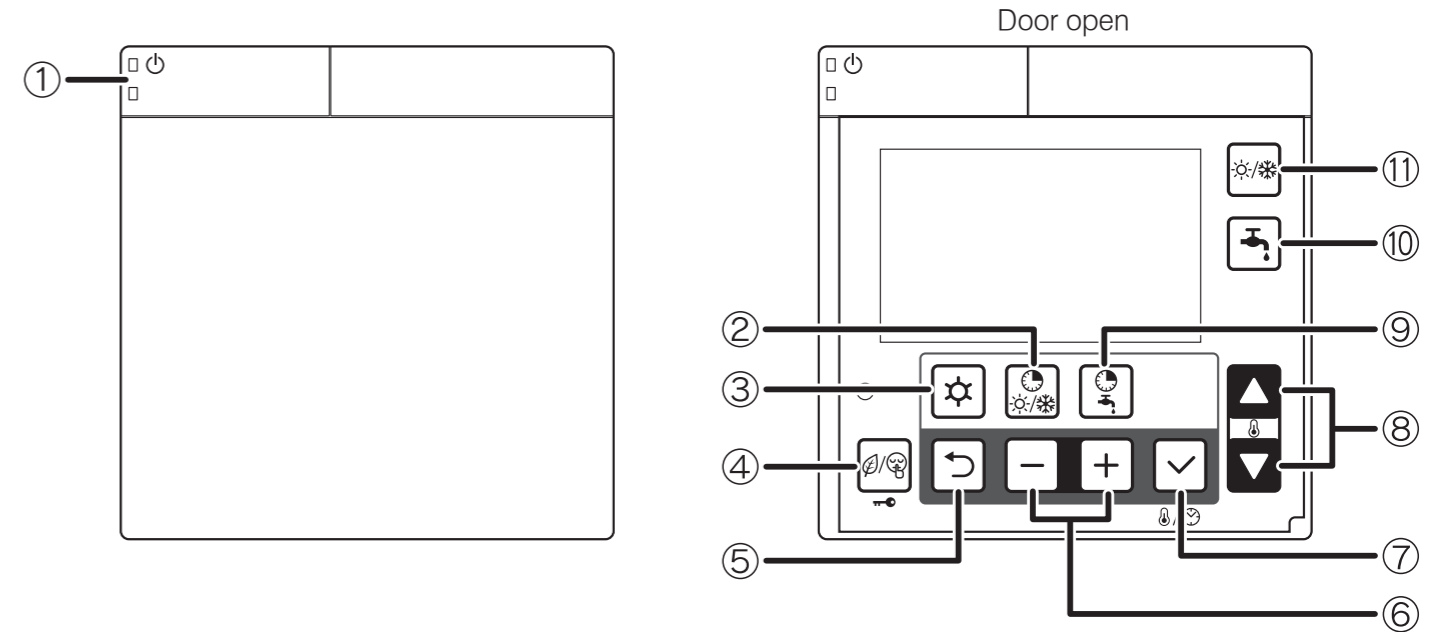

Figure 10-1: Remote controller buttons

### Display on Remote controller

1. Press Return button for three seconds to enter monitor mode and display the user level value of parameter group 01. A 2 digit code number of parameter group 01 (default value is 00) will be displayed on the left of remote controller screen. The corresponding parameter value will be displayed on the right of the screen (default value is ----.)
2. Press the Up or Down q buttons to change the code number and then press the Set p button to display the parameter value. Only code numbers from 00 to 09 can be displayed.
3. To return to normal display, press and hold the Menu | button for three seconds or simply do nothing and leave it for about ten minutes.

### Display on Terminal PCB display

1. Set the DIP SW4 on the Terminal PCB to 'ON' (up) to display the monitor number and monitor data alternately.
2. Push the Pump SW. of the Terminal PCB to switch the display number alternately.
3. To return to normal display, set the DIP SW4 to 'OFF' (down).

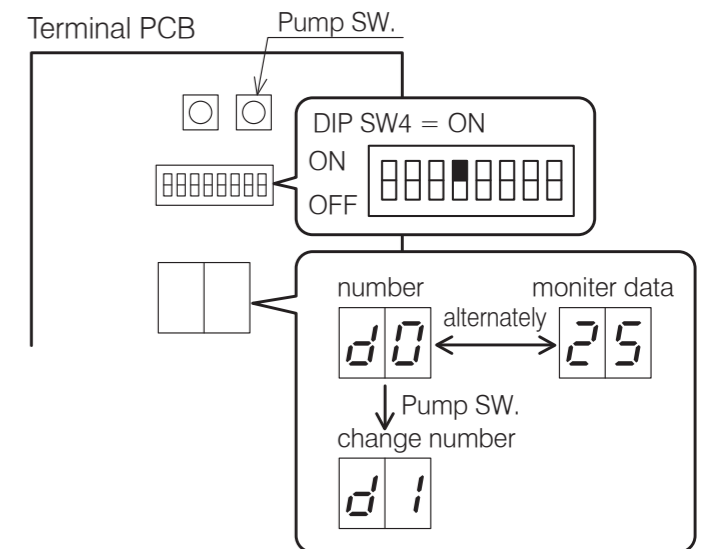

Figure 10-2: Display on Terminal PCB display

Table 10-3: Monitor display

Terminal PCB Number	Remote controller Level	Remote controller Parameter		Function description	Display and input value			
		Group	Code		Default	Minimum	Maximum	Unit
d0	U	01	00	Circulating water return temperature	-	-20	100	1°C
d1	U	01	01	Compressor operating frequency	-	0	200	1Hz
d2	U	01	02	Discharge temperature	-	-20	150	1°C
d3	U	01	03	Power consumption value	-	0	9900	100W
d4	U	01	04	Fan control number of rotation	-	0	1000	10rpm
d5	U	01	05	Defrost temperature	-	-20	100	1°C
d6	U	01	06	Outdoor air temperature	-	-20	100	1°C
d7	U	01	07	Water pump control number of rotation	-	0	9900	100rpm
d8	U	01	08	Suction temperature	-	-20	100	1°C
d9	U	01	09	Circulating water flow temperature	-	-20	100	1°C

# 11 FAULT FINDING

## 11.1 Error Code Display

In the event that a fault is detected, a red LED on the ON/OFF switch of the remote controller will flash and a warning icon and error code will be displayed on LCD screen and also on the Terminal PCB display.

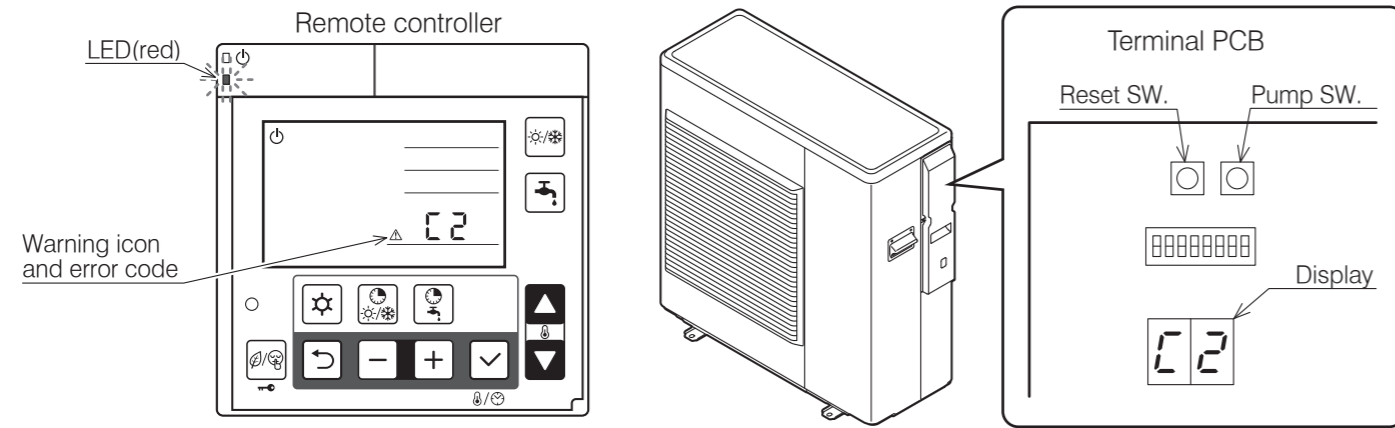

Figure 11-1: Error code display

## 11.2 Error History Display

The previous 10 error codes can be displayed on Terminal PCB display.

### Procedure to display on Terminal PCB display:

1. Press Pump SW and Reset SW on Terminal PCB at the same time for five seconds and the error history order and error code will be displayed alternately. The first one is the latest error code.
2. Press Pump SW to go through the history order up to the 10th error code and then go back to the latest error code.
3. When there is no error history, '--' will be displayed.

If no operation is carried out for five minutes or both the Pump SW and Reset SW are pressed together for five seconds, the display returns to normal display.

### Deletion of the error history:

During error code display, press Reset SW and Pump SW for ten seconds to delete the error history.

## 11.3 Reset Error Code Display

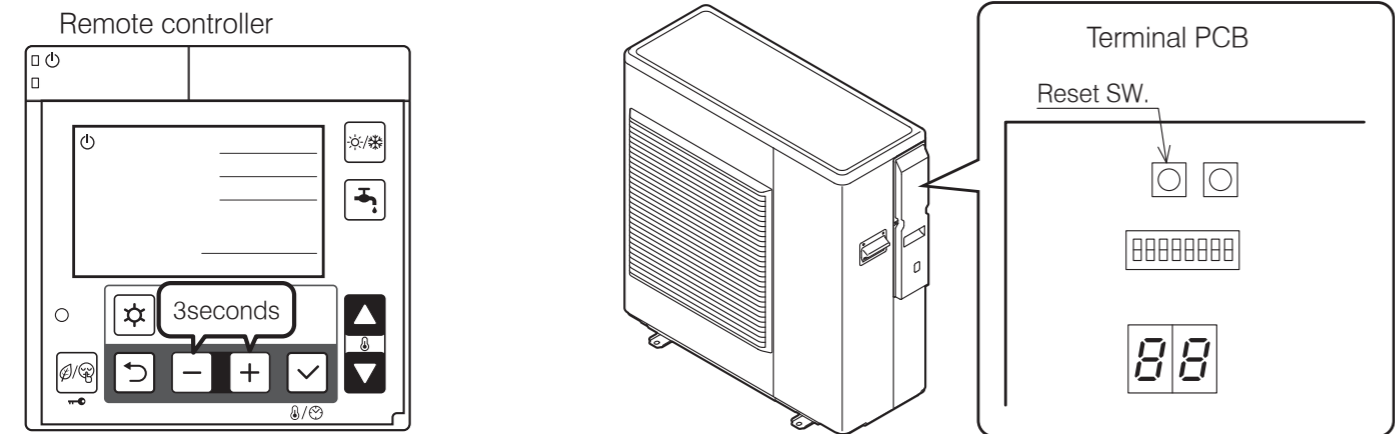

Figure 11-2: Resetting error code display

### Auto

Once it returns to normal condition, the error will automatically be reset.

When the heat pump stops, it may not possible to reset automatically. In this case, reset manually.

### Manual

To reset, press -- and + O buttons on the Remote Controller at the same time for three seconds, or press Reset SW on the Terminal PCB.

Refer to Figure 11-2.

It is possible to reset by turning the mains power supply switch OFF ON, although this is not recommended.

## 11.4 Error Codes

Error code	Error	Method of check	Troubleshooting		Error reset	
-	Power supply	Check the power supply	Confirm the power supply	-	-	
	Fuse CF1 HPID6: 250V 15A HPID10: 250V 25A HPID16: 250V 30A	Check the electric continuity of Fuse CF1 by tester	If CF1 is blown, Main PCB should be replaced	Figure 11-3		
	Fuse CF3 (250V 3A)	Check the electric continuity of Fuse CF3 by tester	If CF3 is blown, Main PCB should be replaced			
	Fuse CF4 HPID6: 250V 3A HPID10: 250V 3A	Check the electric continuity of Fuse CF4 by tester	If CF4 is blown, Main PCB should be replaced			
	Main PCB	Other than described above	Main PCB should be replaced			
A0	Fan motor	Operate without lead wire for Fan motor Check the electric continuity of Fuse by tester	If the same error code appears again, Main PCB or Pump should be replaced If other error codes appear, Fan motor should be replaced	Figure 11-4	Power OFF	
	Fuse CF6 HPID16: 250V 3A		If CF6 is blown, it should be replaced			
	Fuse CF7 HPID10: 250V 3A HPID16: 250V 3A	If CF7 is blown, it should be replaced				
	Pump	Operate without lead wire for Pump	If the same error code appears again, Main PCB or Fan motor should be replaced If other error codes appear, Pump should be replaced			
	Reactor	Check the resistance by tester (0.1Ω at 20°C)	If the reactor is faulty, it should be replaced.			
	Main PCB	Check the voltage of Fan motor by tester Check the voltage of Pump by tester	If the voltage is abnormal, PCB (Main should be replaced)	Figure 11-4, 11-6		
A1	Sensor, Temp. Discharge	Check the resistance by tester	If the sensor is faulty, it should be replaced	Figure 11-13	Auto	
	Gas leakage	Check the service valve and refrigerant circuit (pipe)	Collect refrigerant once, then recharge with prescribed mass			
A2	Protective action against excess	Unreasonable operation under/ overload	Check the place of installation (blockage of air inlet & outlet) Check the excess gas	Ensure the installation position to avoid blockage of air inlet & outlet If excess gas is observed, collect all refrigerant once, then recharge with prescribed mass	-	Manual
	Current DC current detection	Drop of power voltage	Check the power voltage (230V)	Confirm the power supply voltage (230V)		
		Main PCB	Operate without the junction connector of Compressor lead wire	If the same error code appears again, Main PCB should be replaced		
		Momentary stop of power (In case of lightning)	-	Restart operation		
		Compressor	Other than described above	Compressor should be replaced		
A3	CT disconnection	Main PCB	-	Main PCB should be replaced		
A4	Protective action against excess	Unreasonable operation under/ overload	Check the place of installation (blockage of air inlet & outlet) Check the excess gas	Ensure the installation position to avoid blockage of air inlet & outlet If excess gas is observed, collect all refrigerant once, then recharge with prescribed mass	-	Manual
	Current AC current detection	Drop of power voltage	Check the power voltage (230V)	Confirm the power supply voltage (230V)		
		Momentary stop of power (In case of lightning)	-	Restart operation		

Error code	Error	Method of check	Troubleshooting		Error reset	
A5	Abnormal revolution of compressor	Unreasonable operation under/overload	Check the place of installation (blockage of air inlet & outlet) Check the excess gas	Ensure the installation position to avoid blockage of air inlet & outlet If excess gas is observed, collect all refrigerant once, then recharge with prescribed mass	-	Manual
		Drop of power voltage	Check the power voltage (230V)	Confirm the power supply voltage (230V)	-	
		Fuse CF6 HPID6: 250V 15A HPID10: 250V 25A	Check the electric continuity Fuse CF6 by tester	If CF6 is blown, Main PCB should be replaced	Figure 11-5	
		Clogged the water Pump and/or water circuit	Check the Pump and water circuit	Remove the blockage, then restart operation	-	
		Drop of power voltage	Check the power voltage (230V) during operation	Confirm the power supply voltage (230V)	-	
		Momentary stop of power (In case of lightning)	-	Restart operation	-	
		Compressor or Main PCB	Other than described above	Compressor should be replaced	-	
A6	Suction temperature sensor error	Sensor, Temp. Suction	Check the resistance by tester	If the sensor is faulty, it should be replaced	Figure 11-14	Auto
A7	Defrost tem sensor error	Sensor, Temp. Defrost	Check the resistance by tester	If the sensor is faulty, it should be replaced	Figure 11-14	
A8	Discharge temp. sensor error	Sensor, Temp. Discharge	Check the resistance by tester (*1)	If the sensor is faulty, it should be replaced	Figure 11-13	
C1	Upper fan motor error (HPID16)	Fuse CF7 (250V T3.15A)	Check the electric continuity Fuse CF7 by tester	If CF7 is blown, Fan motor and CF7 should be replaced If CF7 is not blown, check the voltage of Fan motor If the voltage is normal, Fan motor should be replaced If the voltage is abnormal, Main PCB should be replaced	Figure 11-4	Auto
		Fan motor (*2)				
		Main PCB				
C2	Outdoor temp. sensor error	Sensor, Temp. Outdoor	Check the resistance by tester	If the sensor is faulty, it should be replaced	Figure 11-12	Auto
C3	Lower Fan motor error (HPID16)	Fuse CF6 (HPID16: 250V T3.15A)	Check the electric continuity of Fuse CF6 by tester	If CF6 is blown, it should be replaced	Figure 11-4	Manual
		Fuse CF7 (HPID10: 250V T3.15A)	Check the electric continuity of Fuse CF7 by tester	If CF7 is blown, it should be replaced		
	Fan motor error (HPID6 and HPID10)	Fan motor	Check the voltage of Fan motor by tester	If the voltage is normal, Fan motor should be replaced		
		Main PCB		If the voltage is normal, Main PCB should be replaced		
C4	Rise of temperature (above 110°C) of Main PCB	Mis-installation	Check the place of installation (blockage of air inlet & outlet)	Ensure the installation position to avoid blockage of air inlet & outlet	-	Auto
		Sensor, Temp. Main PCB	-	Main PCB should be replaced		
C5	Main PCB sensor error	Sensor, Temp. Main PCB	-	Main PCB should be replaced	-	Auto
C6	Main PCB error	Main PCB	-	Main PCB should be replaced	-	Power OFF
C7	Controller PCB serial error	Mis wiring or rare contact [Main PCB - Controller PCB connecting cable]	Check the wiring connection and rare contact	After correcting mis wiring, restart operation	-	Auto
		Controller PCB	Other than described above	Controller PCB should be replaced		
		Main PCB	Other than described above	Main PCB should be replaced		
		Earth wire	-	Check if earth wire is properly installed		

(\*1) In case of detecting open circuit of the discharge temperature sensor, error display appears 10 minutes after start operating.

In case of detecting short circuit of the discharge temperature sensor, error display appears immediately.

(\*2) When checking fan motor and/or pump, turn OFF the power supply completely and check at their terminal or connector.

Error code	Error	Method of check	Troubleshooting		Error reset	
C8	Main PCB error	Main PCB	Turn off the power supply, wait for about 3 minutes, then power up again Check loose cable connections and contacts of reactor	If the same error code appears, Main PCB should be replaced	-	Power OFF
E4	Outgoing water temp. sensor error	Sensor, Temp. Outgoing water	Check the resistance by tester	If the sensor is faulty, it should be replaced	Figure 11-15	Auto
E5	Return water temp. sensor error	Sensor, Temp. Return water	Check the resistance by tester	If the sensor is faulty, it should be replaced	-	
FU	High pressure switch is operating (HPID16)	Outside air recirculation	Check temperature difference of Outgoing/Return water (see Monitor display function) Large difference means flow rate is too low	Make sure the position doesn't block the air inlet and outlet	-	Manual
		Clogged water circuit		Remove the blockage, then restart operation		
P1	Pump error	Pump (*2)	Check the voltage of Pump	If the voltage is normal, Pump should be replaced	Figure 11-6	Manual
		Main PCB		If the voltage is abnormal, Main PCB should be replaced		
		Clogged the water Pump and/or water circuit	Check the pump and water circuit	Remove the blockage, then restart operation		
P3	High pressure switch error (HPID16)	High pressure switch	Check loose cable connections and contacts	If the same error code appears, high pressure switch should be replaced	-	Power OFF
U1	Compressor overheat protection relay operation (HPID16)	Compressor overheat protection relay	Check the resistance by tester	If the compressor overheat protection relay is blown, it should be replaced	Figure 11-10	Manual
		Gas leakage	Check the service valve and refrigerant circuit (pipe)	Correct refrigerant once, then recharge with prescribed mass	-	
Water not getting warm		Fuse CF2 0639U: 250V T3.15A 1039U: 250V T3.15A 1639U: 250V T5A	Check the electric continuity of Fuse CF1 by tester	If CF2 is blown, it should be replaced and check the resistance of 4way valve and the resistance of Defrost heater by tester	Figure 11-9	-
		4way valve	Check the resistance of 4way valve by tester	If 4way valve is blown, it should be replaced	Figure 11-7	
		Defrost heater	Check the resistance of Defrost heater by tester	If Defrost heater is blown, it should be replaced	Figure 11-8	
		Short cycle (insufficient air circulation)	Check the blockage of air inlet & outlet	Ensure the installation position to avoid blockage of air inlet & outlet	-	
		Sensor, Temp. Outgoing water and Return water	Check the resistance by tester	If any of these sensors is faulty, it should be replaced	Figure 11-15	
		Gas leakage	Check the service valve and refrigerant circuit (pipe)	After fixing the leakage point, collect the refrigerant once, then recharge with prescribed mass	-	
		Clogged water circuit	Check temperature difference of Outgoing/Return water (see Monitor display function) Large difference means flow rate is too low	Remove the blockage, then restart operation	-	

### 11.5 Table of Controller PCB and Terminal PCB Alarms

Error code	Error	Method of check	Troubleshooting	Error reset		
L0	EEPROM error	PCB(Controller) and PCB(EEPROM)	-	PCB(Controller) and PCB(EEPROM) should be replaced	-	Power OFF
L1	DHW temperature sensor error	Sensor, temperature DHW tank	Check the resistance by tester	If the sensor is faulty, it should be replaced	Figure 11-14	
L2	Outdoor temperature sensor error	Sensor, temperature outdoor	Check the resistance by tester	If the sensor is faulty, it should be replaced	Figure 11-16	
L3	Thermal store temperature sensor error	Sensor, temperature thermal store	Check the resistance by tester	If the sensor is faulty, it should be replaced	Figure 11-14	
L4	Mix water temperature sensor error	Sensor, temperature Mix water	Check the resistance by tester	If the sensor is faulty, it should be replaced	Figure 11-14	
L5	Humidity sensor error	Sensor, Humidity	Check the resistance by tester	If the sensor is faulty, it should be replaced	Figure 11-11	
740	Remote controller communication error	Incorrect remote controller wiring or DIP SW setting	Check loose cable connections and contacts Check DIP SW setting	After having corrected the wiring and DIP SW setting, restart operation	-	Auto
		Loose interface connection cable or contacts	Rear side of remote controller			
		Remote controller	Other than described above	Remote controller should be replaced		
		Controller PCB	Other than described above	Controller PCB should be replaced		
E8	Remote controller communication error	Incorrect remote controller wiring Loose interface connection cable or contacts	Check loose cable connections and contacts	After having corrected the wiring, restart operation	-	
		Controller PCB	Other than described above	Controller PCB should be replaced		
F5	Main PCB communication error	Incorrect main PCB wiring Loose interface connection cable or contacts	Check loose cable connections and contacts	After having corrected the wiring, restart operation	-	
		Main PCB	Other than described above	Main PCB should be replaced		
		Controller PCB	Other than described above	Controller PCB should be replaced		
Terminal PCB cannot be operated		Lead wire of Terminal PCB	Check lead wires are connected to the connectors properly	Connect the connectors to both Terminal PCB and Controller PCB steadily	-	-
Terminal PCB does not display anything		Terminal PCB	Ensure that there is no disconnection for the lead wires	Lead wires should be replaced		
		Terminal PCB	Other than described above	Terminal PCB should be replaced		
		Controller PCB	Other than described above	Controller PCB should be replaced		

### 11.6 Error Codes and PCB Alarm Figures and Tables

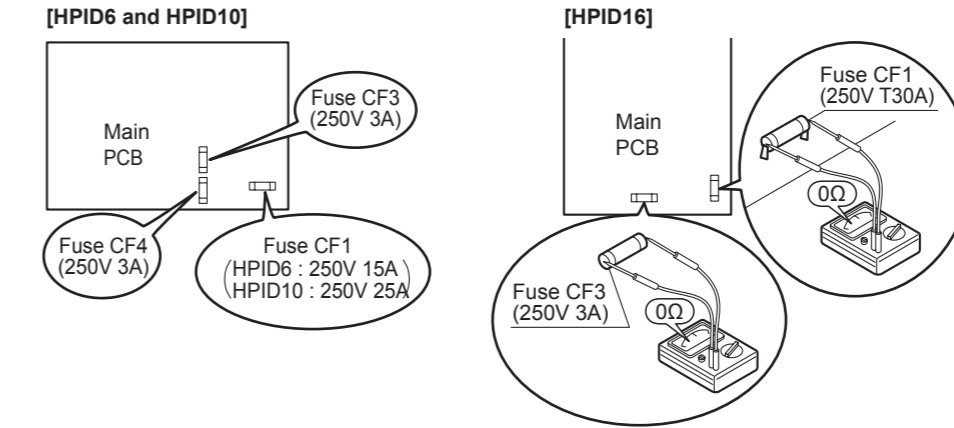

Figure 11-3: Continuity of current Fuse on the Main PCB

Fan motor (HPID6 and HPID10)  
Measure voltage between the connector pins of connector 18.  
Connector 18 shall be checked during heating operation.  
Measure voltage as follows without taking off the connector 18.

LOWER Fan motor (HPID16)  
Measure voltage between the connector pins of connector 11.  
Connector 11 shall be checked during heating operation.  
Measure voltage as follows without taking off the connector 11.

UPPER Fan motor (HPID16)  
Measure voltage between the connector pins of connector 14.  
Connector 14 shall be checked during heating operation.  
Measure voltage as follows without taking off the connector 14.

Between red ⊕ and black ⊖, approx. DC200~370V  
Between yellow ⊕ and black ⊖, approx. DC3~7V  
Between white ⊕ and black ⊖, approx. DC15V

Main PCB is normal

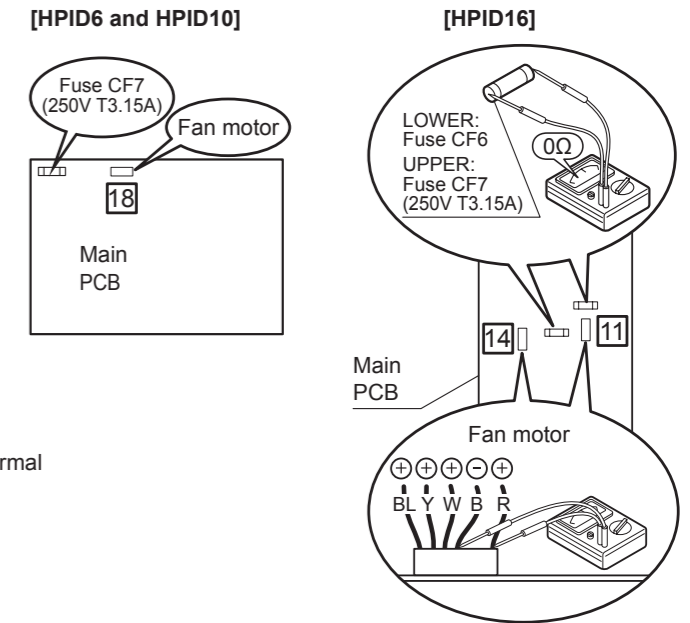

Figure 11-4: Voltage of Fan motor on the Main PCB

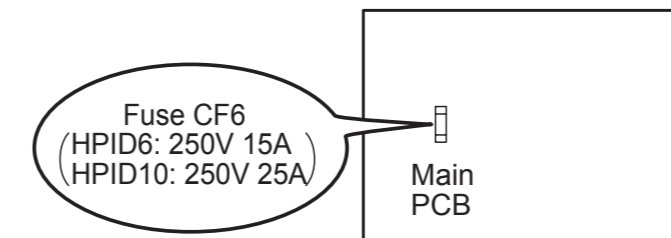

Figure 11-5: Continuity of current Fuse on the Main PCB

Pump (HPID6 and HPID10)  
Measure voltage between the connector pins of connector 17.  
Connector 17 shall be checked during heating operation.  
Measure voltage as follows without taking off the connector 17.

Pump (HPID16)  
Measure voltage between the connector pins of connector 13.  
Connector 13 shall be checked during heating operation.  
Measure voltage as follows without taking off the connector 13.

Between white ⊕ and black ⊖, approx. AC200~370V  
Between brown ⊕ and black ⊖, approx. DC3~7V  
Between red ⊕ and black ⊖, approx. DC15V

Main PCB is normal

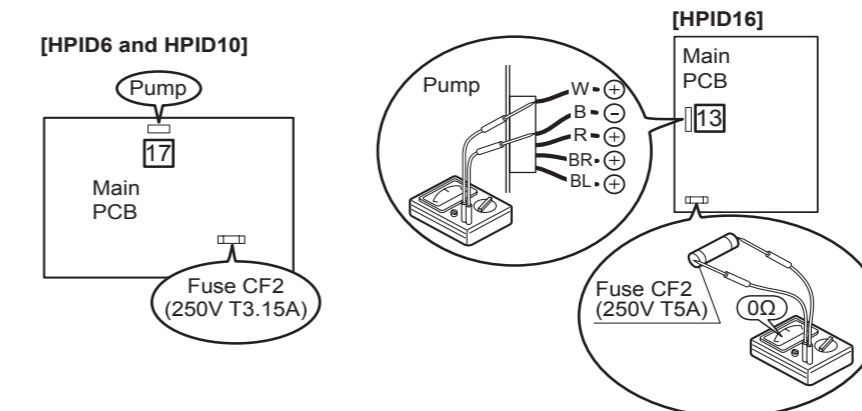

**Figure 11-6:** Voltage of pump on the Main PCB

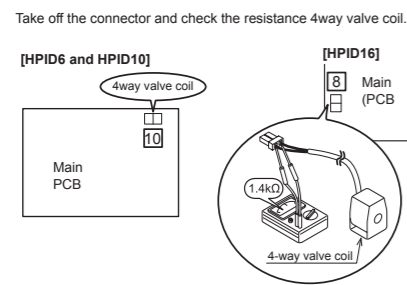

**Figure 11-7:** Resistance of the 4way valve coil

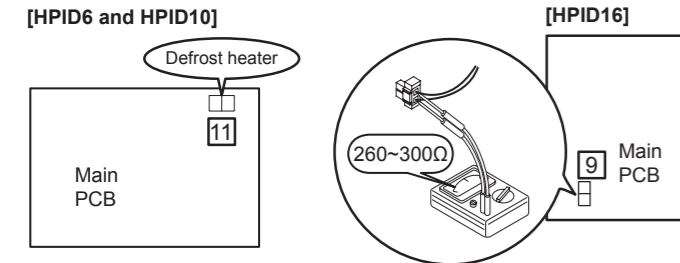

**Figure 11-8:** Resistance of the defrost heater

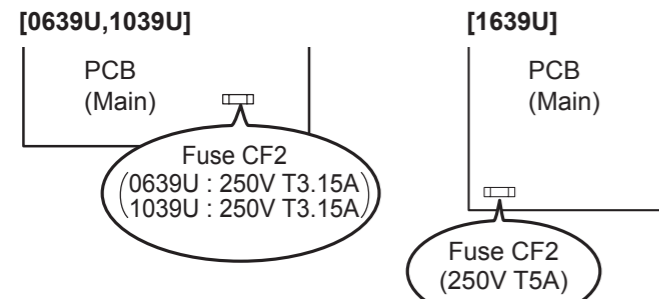

**Figure 11-9:** Continuity of current fuse on the Main PCB

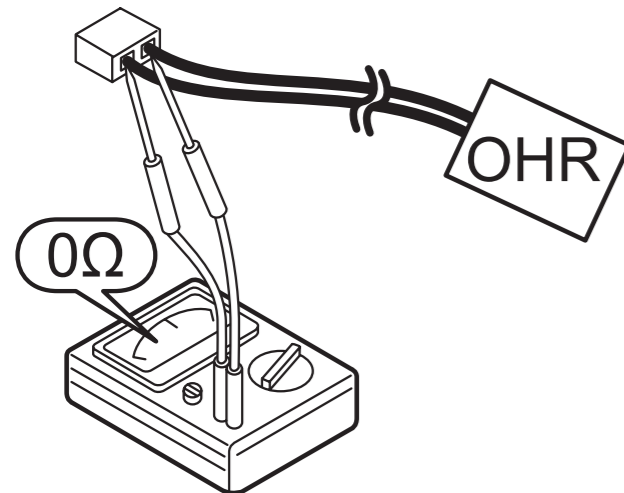

**Figure 11-10:** Resistance of the compressor overheat protection relay

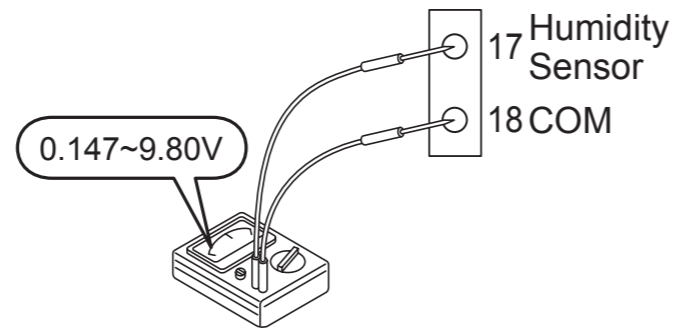

**Figure 11-11:** Voltage of humidity sensor

**Table 11-12:** Sensor, temperature outdoor (heat pump)

Temperature (°C)	Resistance (kΩ)
0	31
5	24
10	19
15	15
20	12
25	10
30	8.2
35	6.7
40	5.5
45	4.6
50	3.8
55	3.2

**Table 11-13:** Sensor, temperature discharge (heat pump)

Temperature (°C)	Resistance (kΩ)
10	100
20	64
35	33
40	27
50	18
80	6.4

**Table 11-14:** Sensor, temperature defrost/suction (heat pump)  
Sensor temperature DHW tank/thermal store/mix water (Terminal PCB)

Temperature (°C)	Resistance (kΩ)
0	29
5	23
10	19
15	15
20	12
25	10
30	8.3
35	6.9
40	5.7
45	4.8
50	4.1
55	3.4

**Table 11-15:** Sensor, temperature flow and return circulating water (heat pump)

Temperature (°C)	Resistance (kΩ)
0	25
10	16
20	10
30	7.0
40	4.9
50	3.5
60	2.5

**Table 11-16:** Sensor, temperature outdoor (Terminal PCB)

Temperature (°C)	Resistance (kΩ)
-20	107
-15	79
-10	59
-5	44
0	34
5	26
10	20
15	16
20	13
25	10
30	8.0
35	6.5
40	5.3
45	4.3
50	3.6

# 12 SPARE PARTS

## 12.1 Exploded Diagram - HPID6

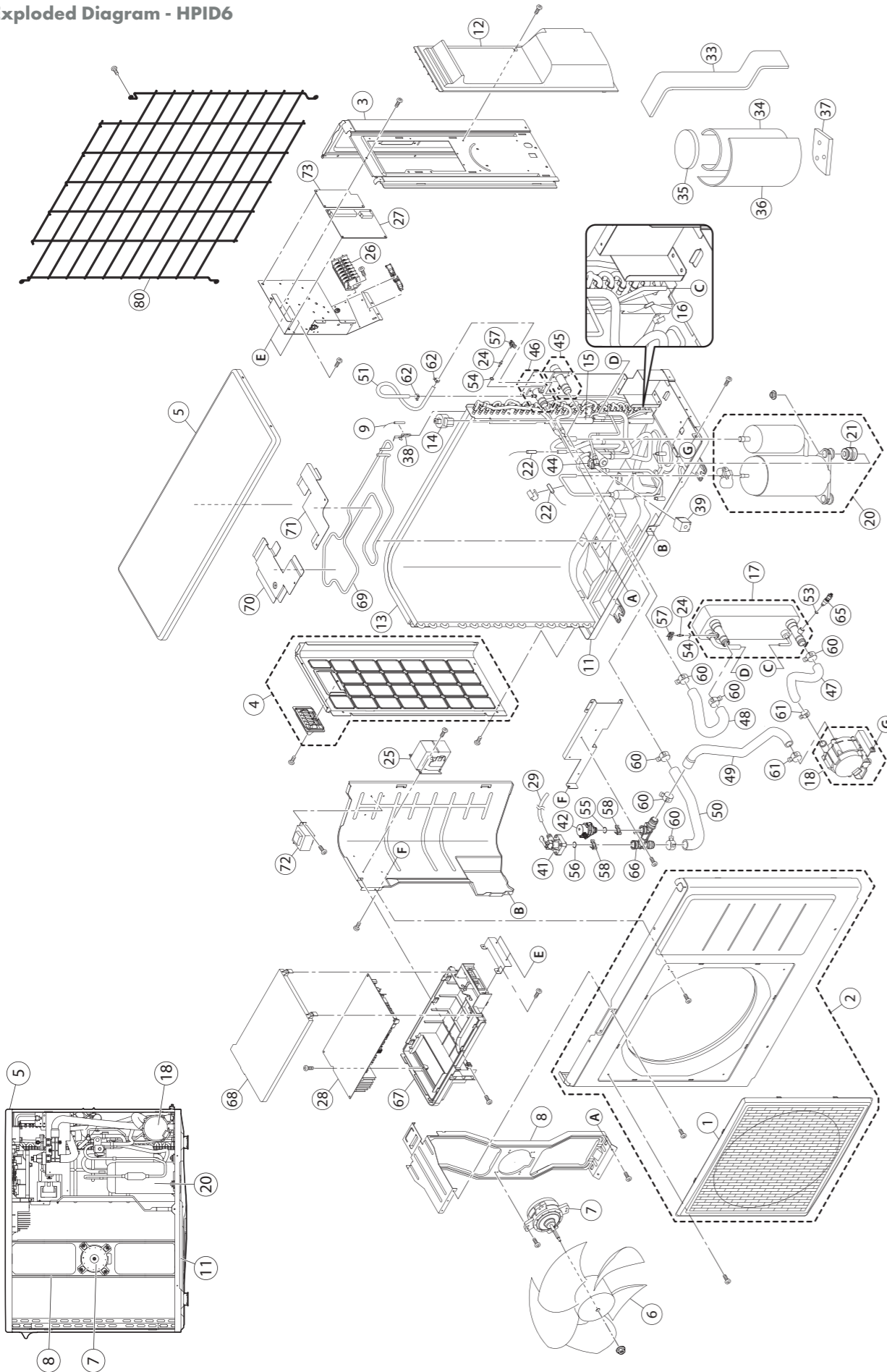

## 12.2 Spare Parts List - HPID6

Item	Description	Product code
1	Outlet grille	HPID927368
2	Front panel assembly	HPID885766
3	Right side panel	HPID883774
4	Left side panel assembly	HPID883741
5	Top panel	HPID884558
6	Propeller fan	HPID922330
7	Motor	HPID937022
8	Bracket (motor)	HPID937023
9	Sensor (temperature outdoor)	HPID883780
11	Bottom panel assembly (without heater)	HPID883759
12	Wiring lid assembly	HPID937262
13	Condenser assembly	HPID883743
14	Coil (expansion valve)	HPID937196
15	Expansion valve	HPID922928
16	Sensor (temperature defrost)	HPID937014
17	Heat exchanger assembly	HPID883744
18	Pump assembly	HPID885394
20	Compressor	HPID937199
21	Vibration proof rubber	HPID883782
22	Sensor (temperature discharge/suction)	HPID937013
24	Sensor (temperature water)	HPID937193
25	Reactor	HPID927200
26	Terminal block	HPID885263
27	Terminal PCB	HPID885254
28	Main PCB	HPID885392
29	Rubber hose (for relief valve)	HPID883784
33	Sound proof material 1	HPID883791
34	Sound proof material 2	HPID883792
35	Sound proof material 3	HPID883793
36	Sound proof material 4	HPID883794
37	Sound proof material 5	HPID883795
38	Outdoor themistor holder	HPID937016
39	Coil - 4-way valve	HPID883796
41	Relief valve	HPID883798
42	Air purge valve	HPID885266
44	4-way valve	HPID927359
45	Circulating water flow port assembly	HPID884560
46	Circulating water return port assembly	HPID883778
47	Rubber hose 1	HPID883786
48	Rubber hose 8	HPID884561
49	Rubber hose 3	HPID885396
50	Rubber hose 4	HPID885397
51	Rubber hose 6	HPID883790
53	O-ring (P3)	HPID807209
54	O-ring (P4)	HPID807207
55	O-ring (P12.5)	HPID808972
56	O-ring (P14)	HPID910164

Item	Description	Product code
57	Quick fastener (for sensor temperature water)	HPID883848
58	Quick fastener (12.7)	HPID790706
60	Hose band A	HPID937221
61	Hose band B	HPID927535
62	Hose band C	HPID934914
65	Drain plug	HPID885519
66	Circulating water connection coupling	HPID885395
67	Case of PCB	HPID883847
68	Case of PCB (cover)	HPID885393
69	Defrost heater	HPID884211
70	Defrost heater holder 1	HPID884212
71	Defrost heater holder 2	HPID884213
72	Power transformer	HPID885264
73	Controller PCB	HPID885765
80	Fin guard	HPID885782



### 12.3 Exploded Diagram - HPID10

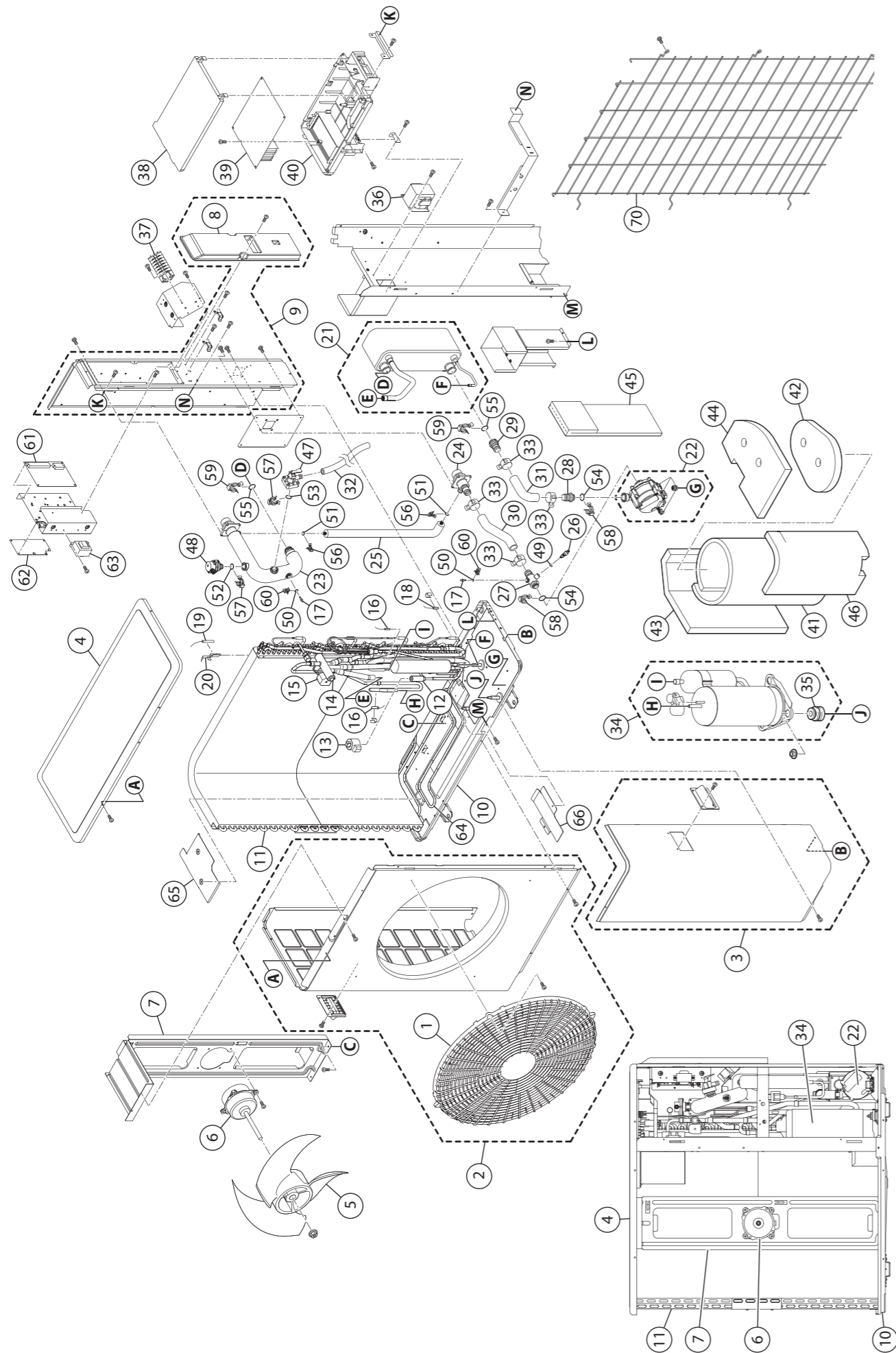

### 12.4 Spare Parts List - HPID10

Item	Description	Product code
1	Outlet grille	HPID938106
2	Front panel assembly (left)	HPID885767
3	Front panel assembly (right)	HPID885768
4	Top panel assembly	HPID885504
5	Propeller fan	HPID934945
6	Motor	HPID885510
7	Bracket (motor)	HPID934947
8	Wiring lid	HPID885507
9	Back panel assembly	HPID885769
10	Bottom panel assembly (without heater)	HPID885506
11	Condenser assembly	HPID883634
12	Expansion valve	HPID885511
13	Coil (expansion valve)	HPID884119
14	4-way valve	HPID938113
15	Coil (4-way valve)	HPID883796
16	Sensor (temperature discharge and suction)	HPID937013
17	Sensor (temperature circulating water)	HPID885265
18	Sensor (temperature defrost)	HPID937014
19	Sensor (temperature outdoor)	HPID883780
20	Outdoor thermistor holder	HPID937016
21	Heat exchanger assembly	HPID885509
22	Pump assembly	HPID885512
23	Circulating water pipe assembly	HPID885513
24	Circulating water return port	HPID885514
25	Bypass pipe assembly	HPID885515
26	Drain plug	HPID885519
27	Hose coupling 1 assembly (pump inlet)	HPID885516
28	Hose coupling 2 assembly (pump outlet)	HPID885271
29	Hose coupling 3 (heat exchanger)	HPID885272
30	Rubber hose (pump inlet water)	HPID885273
31	Rubber hose (pump outlet water)	HPID885517
32	Rubber hose (for relief valve)	HPID885520
33	Hose band	HPID937221
34	Compressor	HPID934944
35	Vibration proof rubber	HPID934959
36	Reactor	HPID885259
37	Terminal block	HPID885263
38	Case of PCB (cover)	HPID885393
39	Main PCB	HPID885501
40	Case of PCB	HPID883847
41	Sound proof material 1	HPID883882
42	Sound proof material 2	HPID883883
43	Sound proof material 3	HPID883884
44	Sound proof material 4	HPID883885
45	Sound proof material 5	HPID884582
46	Sound proof material 6	HPID885518
47	Relief valve	HPID883798
48	Air purge valve	HPID885266
49	O-ring (P3)	HPID807209
50	O-ring (P4)	HPID807207
51	O-ring (P6)	HPID807205
52	O-ring (P12.5)	HPID808972
53	O-ring (P14)	HPID910164
54	O-ring (P16)	HPID807213
55	O-ring (P22)	HPID922856
56	Quick fastener	HPID761569
57	Quick fastener (12.7)	HPID790706
58	Quick fastener (16A)	HPID963516
59	Quick fastener (16B)	HPID884148
60	Quick fastener (sensor temperature water)	HPID883848
61	Terminal PCB	HPID885254
62	Controller PCB	HPID885765
63	Power transformer	HPID885264
64	Defrost heater	HPID885508
65	Defrost heater holder 1	HPID884163
66	Defrost heater holder 2	HPID884132
70	Fin guard	HPID885781

12.5 Exploded Diagram - HPID16

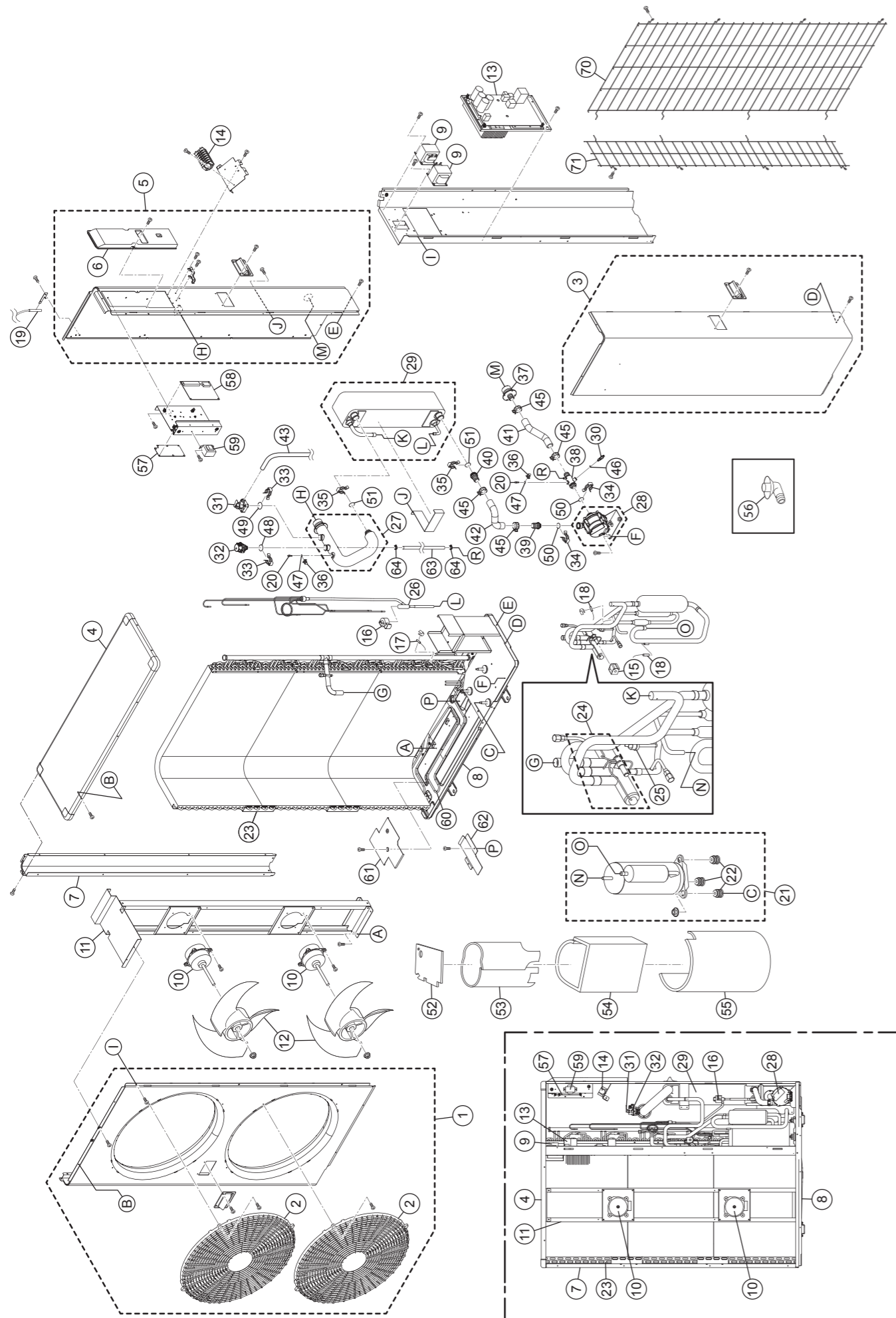

12.6 Spare Parts List - HPID16

Item	Description	Product code
1	Front panel assembly (left)	HPID885255
2	Outlet grille	HPID938106
3	Front panel assembly (right)	HPID885770
4	Top panel assembly	HPID884552
5	Back panel assembly (right)	HPID885257
6	Wiring lid	HPID884129
7	Back panel (left)	HPID884126
8	Bottom panel assembly (without heater)	HPID885258
9	Reactor	HPID885259
10	Motor	HPID885260
11	Bracket (motor)	HPID885261
12	Propeller fan	HPID938112
13	Main PCB assembly	HPID885252
14	Terminal block	HPID885263
15	Coil (4-way valve)	HPID883796
16	Coil (expansion valve)	HPID884119
17	Sensor (temperature defrost)	HPID937014
18	Sensor (temperature discharge and suction)	HPID884139
19	Sensor (temperature outdoor)	HPID884140
20	Sensor (temperature water)	HPID885265
21	Compressor	HPID884116
22	Vibration proof rubber	HPID884135
23	Condenser assembly	HPID884136
24	4-way valve	HPID884117
25	High pressure switch	HPID884120
26	Expansion valve	HPID884118
27	Circulating water pipe assembly	HPID885267
28	Pump assembly	HPID885268
29	Heat exchanger assembly	HPID885262
30	Drain plug	HPID885519
31	Relief valve	HPID883798
32	Air purge valve	HPID885266
33	Quick fastener (12.7)	HPID790706
34	Quick fastener (16A)	HPID963516
35	Quick fastener (16B)	HPID884148
36	Quick fastener (sensor temperature water)	HPID883848
38	Circulating water return port	HPID885269
38	Hose coupling 1 assembly (pump input)	HPID885270
39	Hose coupling 2 (pump outlet)	HPID885271
40	Hose coupling 3 (heat exchanger)	HPID885272
41	Rubber hose (pump input)	HPID885273
42	Rubber hose (pump outlet)	HPID885274
43	Rubber hose (relief valve)	HPID934970
45	Hose band	HPID937221
46	O-ring (P3)	HPID807209
47	O-ring (P4)	HPID807207
48	O-ring (P12.5)	HPID808972
49	O-ring (P14)	HPID910164
50	O-ring (P16)	HPID807213
51	O-ring (P22)	HPID922856
52	Drain elbow	HPID884142
53	Sound proof material 1	HPID884143
54	Sound proof material 2	HPID885276
55	Sound proof material 3	HPID885277
56	Drain elbow	HPID881618
57	Controller PCB	HPID885765
58	Terminal PCB	HPID885254
59	Power transformer	HPID885264
60	Defrost heater	HPID884130
61	Defrost heater holder 1	HPID884131
62	Defrost heater holder 2	HPID884132
63	Rubber hose	HPID885275
64	Hose band	HPID934914
70	Fin guard - back	HPID885779
71	Fin guard - side	HPID885780

Item	Description	Product code
49	O-ring (P14)	HPID910164
50	O-ring (P16)	HPID807213
51	O-ring (P22)	HPID922856
52	Drain elbow	HPID884142
53	Sound proof material 1	HPID884143
54	Sound proof material 2	HPID885276
55	Sound proof material 3	HPID885277
56	Drain elbow	HPID881618
57	Controller PCB	HPID885765
58	Terminal PCB	HPID885254
59	Power transformer	HPID885264
60	Defrost heater	HPID884130
61	Defrost heater holder 1	HPID884131
62	Defrost heater holder 2	HPID884132
63	Rubber hose	HPID885275
64	Hose band	HPID934914
70	Fin guard - back	HPID885779
71	Fin guard - side	HPID885780

# 13 EC DECLARATION OF CONFORMITY

This declaration is made under the sole responsibility of the following Manufacturer.

The Manufacturer declares that the following Products conform to the requirements of EU Directives, Regulations and Harmonized Standards as below stated.

The Technical Construction Files are retained at the following Manufacturer's location.

**Product:** Air to Water Heat Pump  
**Model:** Grant Aeron<sup>3</sup> HPID6  
Grant Aeron<sup>3</sup> HPID10  
Grant Aeron<sup>3</sup> HPID16

**Low Voltage Directive:** 2014/35/EU

**Machinery Directive:** 2006/42/EC

EN 60335-2-40: 2003, +A11: 2004, +A12: 2005, +A1: 2006, +A2: 2009, +A13: 2012

EN 60335-1: 2012, +A11: 2014

EN 62233: 2008

**EMC Directive:** 2014/30/EU

EN 61000-6-1: 2007

EN 61000-6-3: 2007, +A1: 2001

**Ecodesign Directive:** 2009/125/EC [Space heaters and combination heaters: 811/2013; 813/2013]

EN 14511-3: 2013

EN 14825: 2013

EN 12102: 2013

EN 16147: 2011

BS EN ISO 3743-1: 2010

**RoHS Directive:** 2011/65/EU

EN 50581: 2012

**Place of issue:** Ireland

**Date of issue:** 6th of June 2018

**Authorised Signatory:**

Peter Darcy - R&D Manager

# 14 HEALTH AND SAFETY INFORMATION

## 14.1 General

Under the Consumer Protection Act 1987 and Section 6 of the Health and Safety at Work Act 1974, we are required to provide information on substances hazardous to health (COSHH Regulations 1988).

Adhesives, sealants and paints used in the manufacture of the product are cured and present no known hazards when used in the manner for which they are intended.



WARNING

**Isolate the heat pump from the electricity supply before removing any covers.**

## 14.2 Refrigerant (R410A)

The refrigerant is hermetically sealed within the heat pump.

Work involving the refrigerant must only be performed by a qualified F-Gas Engineer or an authorised dealer with a refrigerant handling certificate.

Under no circumstances should the refrigerant be vented or otherwise released to the atmosphere.

### 14.2.1 First Aid Measures

#### Inhalation

In low concentrations may cause narcotic effects. Symptoms may include

dizziness, headache, nausea and loss of co-ordination.

In high concentrations may cause asphyxiation. Symptoms may include loss of mobility/consciousness. Victim may not be aware of asphyxiation.

Remove victim to uncontaminated area wearing self contained breathing apparatus. Keep victim warm and rested. Seek urgent medical advice.

Apply artificial respiration if breathing stopped.

#### Skin/eye contact

In case of frostbite spray with water for at least 15 minutes. Apply a sterile dressing.

Immediately flush eyes thoroughly with water for at least 15 minutes.

Remove contaminated clothing. Drench affected area with water for at least 15 minutes.

Obtain medical assistance

#### Ingestion

Ingestion is not considered a potential route of exposure.

# 15 DISPOSAL AND RECYCLING

## General

Grant IRL air source heat pumps incorporate components manufactured from a variety of different materials. However, most of these materials cannot be recycled as they are contaminated by the refrigerant and oil used in the heat pump.

## Disassembly

This product may only be disassembled by a suitably qualified (F-gas) refrigeration engineer.

Under no circumstances should the refrigerant be released into the atmosphere.

## Recycling

In order for the heat pump to be recycled or disposed of it must be taken to a suitably licensed waste facility. You will need to contact a qualified refrigeration engineer to do this for you.

## Disposal

The refrigerant will be removed and returned to the refrigerant manufacturer for recycling or disposal.

The complete heat pump unit, including the compressor and the oil contained within it, must be disposed of at a licensed waste facility, as it still remains contaminated by the refrigerant.

# 16 PRODUCT FICHE

Product fiche concerning the Commission Delegated Regulations  
(EU)No 811/2013 of 18 February 2013  
(EU)No 813/2013 of 2 August 2013

Models: Outdoor Unit: Aerona<sup>3</sup> HPID6  
Indoor Unit: None  
Air-to-water heat pump: Yes  
Brine-to-water heat pump: No  
Low temperature heat pump: No  
Equipped with a supplementary heater: No  
Heat Pump Combination Heater: No  
Parameters shall be declared for: Low temperature applications  
Parameters shall be declared for: Average climate conditions

Item	Symbol	Value	Unit	Item	Symbol	Value	Unit
Rated heat output (*)	Prated	4.8	kW	Seasonal space heat energy efficiency	s	174	%
Declared capacity for heating for part load at indoor temperature 20°C and outdoor temperature T <sub>i</sub>				Declared coefficient of performance or primary energy ratio for part load at indoor temperature 20°C and outdoor temperature T <sub>i</sub>			
T <sub>i</sub> = -10°C	Pdh	4.8	kW	T <sub>i</sub> = -10°C	COPd	2.40	
Degradation co-efficient (**)	Cdh	0.99	-				
T <sub>i</sub> = -7°C	Pdh	4.23	kW	T <sub>i</sub> = -7°C	COPd	2.60	
Degradation co-efficient (**)	Chd	0.99	-				
T <sub>i</sub> = +2°C	Pdh	2.70	kW	T <sub>i</sub> = +2°C	COPd	4.40	
Degradation co-efficient (**)	Cdh	0.98	-				
T <sub>i</sub> = +7°C	Pdh	1.92	kW	T <sub>i</sub> = +7°C	COPd	6.10	
Degradation co-efficient (**)	Cdh	0.97	-				
T <sub>i</sub> = +12°C	Pdh	2.30	kW	T <sub>i</sub> = +12°C	COPd	7.98	
Degradation co-efficient (**)	Cdh	0.97	-				
T <sub>i</sub> = bivalent temperature	Pdh	4.8	kW	T <sub>i</sub> = bivalent temperature	COPd	2.40	
T <sub>i</sub> = operation limit temperature	Pdh	4.8	kW	T <sub>i</sub> = operation limit temperature	COPd	2.40	
T <sub>i</sub> = -15°C (if TOL < -20°C)	Pdh	-	kW	T <sub>i</sub> = -15°C (if TOL < -20°C)	COPd	-	
Bivalent temperature	Tbiv	-10		Operation limit temperature	TOL	-10	°C
				Heating water operating limit temperature	WTOL	60	°C

Power consumption in modes other than active mode				Supplementary heater			
Off Mode	P <sub>off</sub>	0.01	kW	Rate heat output	P <sub>sup</sub>	0	kW
Thermostat off mode	P <sub>to</sub>	0.04	kW				
Standby mode	P <sub>se</sub>	0.01	kW	Type of energy input			
Crankcase heater mode	P <sub>cx</sub>	0.00	kW				

Other items							
Capacity control	Variable			Rated airflow rate, outdoors	-	2082	m <sup>3</sup> /h
Sound power level indoor/outdoor	L <sub>wa</sub>	40/61	dBA				
Annual energy consumption	Q <sub>he</sub>	2194	kWh				

For heat pump combination heater				Water heating energy efficiency			
Declared heat load profile	-	-	-				
Daily electricity consumption	Q <sub>elec</sub>	-	kWh				
Annual electricity consumption	AEC	-	kWh				

(\*) For heat pump space heaters and heat pump combination heaters, the rated heat output Prated is equal to the design load for heating. Pdesignh, and the rated heat output of a supplementary Psup is equal to the supplementary capacity for heating sup(T<sub>i</sub>).  
(\*\*) If Cdh is not determined by measurement then the default degradation coefficient is Cdh = 0.9.  
Version 1.1 - June 2017

Models: Outdoor Unit: Aerona<sup>3</sup> HPID6  
Indoor Unit: None  
Air-to-water heat pump: Yes  
Brine-to-water heat pump: No  
Low temperature heat pump: No  
Equipped with a supplementary heater: No  
Heat Pump Combination Heater: No  
Parameters shall be declared for: Medium temperature applications  
Parameters shall be declared for: Average climate conditions

Item	Symbol	Value	Unit	Item	Symbol	Value	Unit
Rated heat output (*)	Prated	4.8	kW	Seasonal space heat energy efficiency	s	126	%
Declared capacity for heating for part load at indoor temperature 20°C and outdoor temperature T <sub>i</sub>				Declared coefficient of performance or primary energy ratio for part load at indoor temperature 20°C and outdoor temperature T <sub>i</sub>			
T <sub>i</sub> = -10°C	Pdh	4.8	kW	T <sub>i</sub> = -10°C	COPd	1.61	
Degradation co-efficient (**)	Cdh	0.99	-				
T <sub>i</sub> = -7°C	Pdh	4.22	kW	T <sub>i</sub> = -7°C	COPd	1.91	
Degradation co-efficient (**)	Chd	0.99	-				
T <sub>i</sub> = +2°C	Pdh	2.61	kW	T <sub>i</sub> = +2°C	COPd	3.35	
Degradation co-efficient (**)	Cdh	0.99	-				
T <sub>i</sub> = +7°C	Pdh	1.87	kW	T <sub>i</sub> = +7°C	COPd	4.10	
Degradation co-efficient (**)	Cdh	0.98	-				
T <sub>i</sub> = +12°C	Pdh	2.20	kW	T <sub>i</sub> = +12°C	COPd	4.90	
Degradation co-efficient (**)	Cdh	0.98	-				
T <sub>i</sub> = bivalent temperature	Pdh	4.8	kW	T <sub>i</sub> = bivalent temperature	COPd	1.61	
T <sub>i</sub> = operation limit temperature	Pdh	4.8	kW	T <sub>i</sub> = operation limit temperature	COPd	1.61	
T <sub>i</sub> = -15°C (if TOL < -20°C)	Pdh	-	kW	T <sub>i</sub> = -15°C (if TOL < -20°C)	COPd	-	
Bivalent temperature	Tbiv	-10		Operation limit temperature	TOL	-10	°C
				Heating water operating limit temperature	WTOL	60	°C

Power consumption in modes other than active mode				Supplementary heater			
Off Mode	P <sub>off</sub>	0.01	kW	Rate heat output	P <sub>sup</sub>	0	kW
Thermostat off mode	P <sub>to</sub>	0.04	kW				
Standby mode	P <sub>se</sub>	0.01	kW	Type of energy input			
Crankcase heater mode	P <sub>cx</sub>	0.00	kW				

Other items							
Capacity control	Variable			Rated airflow rate, outdoors	-	2082	m <sup>3</sup> /h
Sound power level indoor/outdoor	L <sub>wa</sub>	42/63	dBA				
Annual energy consumption	Q <sub>he</sub>	2998	kWh				

For heat pump combination heater				Water heating energy efficiency			
Declared heat load profile	-	-	-				
Daily electricity consumption	Q <sub>elec</sub>	-	kWh				
Annual electricity consumption	AEC	-	kWh				

(\*) For heat pump space heaters and heat pump combination heaters, the rated heat output Prated is equal to the design load for heating. Pdesignh, and the rated heat output of a supplementary Psup is equal to the supplementary capacity for heating sup(T<sub>i</sub>).  
(\*\*) If Cdh is not determined by measurement then the default degradation coefficient is Cdh = 0.9.  
Version 1.1 - June 2017

Models: Outdoor Unit: Aerona<sup>3</sup> HPID10  
Indoor Unit: None  
Air-to-water heat pump: Yes  
Brine-to-water heat pump: No  
Low temperature heat pump: No  
Equipped with a supplementary heater: No  
Heat Pump Combination Heater: No  
Parameters shall be declared for: Low temperature applications  
Parameters shall be declared for: Average climate conditions

Item	Symbol	Value	Unit	Item	Symbol	Value	Unit
Rated heat output (*)	Prated	7.5	kW	Seasonal space heat energy efficiency	s	174	%
Declared capacity for heating for part load at indoor temperature 20°C and outdoor temperature Tj				Declared coefficient of performance or primary energy ratio for part load at indoor temperature 20°C and outdoor temperature Tj			
Tj = -10°C	Pdh	7.5	kW	Tj = -10°C	COPd	2.35	
Degradation co-efficient (**)	Cdh	0.99	-				
Tj = -7°C	Pdh	6.74	kW	Tj = -7°C	COPd	2.65	
Degradation co-efficient (**)	Chd	0.99	-				
Tj = +2°C	Pdh	4.15	kW	Tj = +2°C	COPd	4.52	
Degradation co-efficient (**)	Cdh	0.99	-				
Tj = +7°C	Pdh	3.02	kW	Tj = +7°C	COPd	5.89	
Degradation co-efficient (**)	Cdh	0.98	-				
Tj = +12°C	Pdh	4.70	kW	Tj = +12°C	COPd	6.35	
Degradation co-efficient (**)	Cdh	0.99	-				
Tj = bivalent temperature	Pdh	7.50	kW	Tj = bivalent temperature	COPd	2.35	
Tj = operation limit temperature	Pdh	7.50	kW	Tj = operation limit temperature	COPd	2.35	
Tj = -15°C (if TOL < -20°C)	Pdh	-	kW	Tj = -15°C (if TOL < -20°C)	COPd	-	
Bivalent temperature	Tbiv	-10		Operation limit temperature	TOL	-10	°C
				Heating water operating limit temperature	WTOL	60	°C

Power consumption in modes other than active mode				Supplementary heater			
Off Mode	P <sub>off</sub>	0.01	kW	Rate heat output	P <sub>sup</sub>	0	kW
Thermostat off mode	P <sub>to</sub>	0.04	kW				
Standby mode	P <sub>sa</sub>	0.01	kW	Type of energy input			
Crankcase heater mode	P <sub>cx</sub>	0.00	kW				

Other items							
Capacity control	Variable			Rated airflow rate, outdoors	-	2664	m <sup>3</sup> /h
Sound power level indoor/outdoor	L <sub>wa</sub>	44/65	dB(A)				
Annual energy consumption	Q <sub>he</sub>	3318	kWh				

For heat pump combination heater				Water heating energy efficiency			
Declared heat load profile	-	-	-				
Daily electricity consumption	Q <sub>elec</sub>	-	kWh				
Annual electricity consumption	AEC	-	kWh				

(\*) For heat pump space heaters and heat pump combination heaters, the rated heat output Prated is equal to the design load for heating. Pdesignh, and the rated heat output of a supplementary Psup is equal to the supplementary capacity for heating sup(Tj).  
(\*\*) If Cdh is not determined by measurement then the default degradation coefficient is Cdh = 0.9.  
Version 1.1 - June 2017

Models: Outdoor Unit: Aerona<sup>3</sup> HPID10  
Indoor Unit: None  
Air-to-water heat pump: Yes  
Brine-to-water heat pump: No  
Low temperature heat pump: No  
Equipped with a supplementary heater: No  
Heat Pump Combination Heater: No  
Parameters shall be declared for: Medium temperature applications  
Parameters shall be declared for: Average climate conditions

Item	Symbol	Value	Unit	Item	Symbol	Value	Unit
Rated heat output (*)	Prated	7.5	kW	Seasonal space heat energy efficiency	s	126	%
Declared capacity for heating for part load at indoor temperature 20°C and outdoor temperature Tj				Declared coefficient of performance or primary energy ratio for part load at indoor temperature 20°C and outdoor temperature Tj			
Tj = -10°C	Pdh	6.9	kW	Tj = -10°C	COPd	1.63	
Degradation co-efficient (**)	Cdh	0.99	-				
Tj = -7°C	Pdh	6.68	kW	Tj = -7°C	COPd	1.91	
Degradation co-efficient (**)	Chd	0.99	-				
Tj = +2°C	Pdh	4.01	kW	Tj = +2°C	COPd	3.09	
Degradation co-efficient (**)	Cdh	0.99	-				
Tj = +7°C	Pdh	2.80	kW	Tj = +7°C	COPd	4.51	
Degradation co-efficient (**)	Cdh	0.98	-				
Tj = +12°C	Pdh	4.30	kW	Tj = +12°C	COPd	6.71	
Degradation co-efficient (**)	Cdh	0.99	-				
Tj = bivalent temperature	Pdh	6.90	kW	Tj = bivalent temperature	COPd	1.63	
Tj = operation limit temperature	Pdh	6.90	kW	Tj = operation limit temperature	COPd	1.63	
Tj = -15°C (if TOL < -20°C)	Pdh	-	kW	Tj = -15°C (if TOL < -20°C)	COPd	-	
Bivalent temperature	Tbiv	-10		Operation limit temperature	TOL	-10	°C
				Heating water operating limit temperature	WTOL	60	°C

Power consumption in modes other than active mode				Supplementary heater			
Off Mode	P <sub>off</sub>	0.01	kW	Rate heat output	P <sub>sup</sub>	0.6	kW
Thermostat off mode	P <sub>to</sub>	0.04	kW				
Standby mode	P <sub>sa</sub>	0.01	kW	Type of energy input			
Crankcase heater mode	P <sub>cx</sub>	0.00	kW				

Other items							
Capacity control	Variable			Rated airflow rate, outdoors	-	2664	m <sup>3</sup> /h
Sound power level indoor/outdoor	L <sub>wa</sub>	46/67	dB(A)				
Annual energy consumption	Q <sub>he</sub>	4762	kWh				

For heat pump combination heater				Water heating energy efficiency			
Declared heat load profile	-	-	-				
Daily electricity consumption	Q <sub>elec</sub>	-	kWh				
Annual electricity consumption	AEC	-	kWh				

(\*) For heat pump space heaters and heat pump combination heaters, the rated heat output Prated is equal to the design load for heating. Pdesignh, and the rated heat output of a supplementary Psup is equal to the supplementary capacity for heating sup(Tj).  
(\*\*) If Cdh is not determined by measurement then the default degradation coefficient is Cdh = 0.9.  
Version 1.1 - June 2017

Models: Outdoor Unit: Aerona<sup>3</sup> HPID16  
Indoor Unit: None  
Air-to-water heat pump: Yes  
Brine-to-water heat pump: No  
Low temperature heat pump: No  
Equipped with a supplementary heater: No  
Heat Pump Combination Heater: No  
Parameters shall be declared for: Low temperature applications  
Parameters shall be declared for: Average climate conditions

Item	Symbol	Value	Unit	Item	Symbol	Value	Unit
Rated heat output (*)	Prated	12.75	kW	Seasonal space heat energy efficiency	s	167	%
Declared capacity for heating for part load at indoor temperature 20°C and outdoor temperature Tj				Declared coefficient of performance or primary energy ratio for part load at indoor temperature 20°C and outdoor temperature Tj			
Tj = -10°C	Pdh	11.8	kW	Tj = -10°C	COPd	2.30	
Degradation co-efficient (**)	Cdh	0.99	-				
Tj = -7°C	Pdh	11.31	kW	Tj = -7°C	COPd	2.73	
Degradation co-efficient (**)	Chd	0.99	-				
Tj = +2°C	Pdh	6.81	kW	Tj = +2°C	COPd	4.21	
Degradation co-efficient (**)	Cdh	0.99	-				
Tj = +7°C	Pdh	4.61	kW	Tj = +7°C	COPd	5.73	
Degradation co-efficient (**)	Cdh	0.99	-				
Tj = +12°C	Pdh	4.80	kW	Tj = +12°C	COPd	6.30	
Degradation co-efficient (**)	Cdh	0.99	-				
Tj = bivalent temperature	Pdh	11.8	kW	Tj = bivalent temperature	COPd	2.30	
Tj = operation limit temperature	Pdh	11.8	kW	Tj = operation limit temperature	COPd	2.30	
Tj = -15°C (if TOL < -20°C)	Pdh	-	kW	Tj = -15°C (if TOL < -20°C)	COPd	-	
Bivalent temperature	Tbiv	-10		Operation limit temperature	TOL	-10	°C
				Heating water operating limit temperature	WTOL	60	°C

Power consumption in modes other than active mode				Supplementary heater			
Off Mode	P <sub>off</sub>	0.01	kW	Rate heat output	P <sub>sup</sub>	0.95	kW
Thermostat off mode	P <sub>to</sub>	0.04	kW				
Standby mode	P <sub>sa</sub>	0.01	kW	Type of energy input			
Crankcase heater mode	P <sub>cx</sub>	0.00	kW				

Other items							
Capacity control	Variable			Rated airflow rate, outdoors	-	4464	m <sup>3</sup> /h
Sound power level indoor/outdoor	L <sub>wa</sub>	40/61	dB(A)				
Annual energy consumption	Q <sub>he</sub>	6058	kWh				

For heat pump combination heater				Water heating energy efficiency			
Declared heat load profile	-	-	-				
Daily electricity consumption	Q <sub>elec</sub>	-	kWh				
Annual electricity consumption	AEC	-	kWh				

(\*) For heat pump space heaters and heat pump combination heaters, the rated heat output Prated is equal to the design load for heating. Pdesignh, and the rated heat output of a supplementary Psup is equal to the supplementary capacity for heating sup(Tj).  
(\*\*) If Cdh is not determined by measurement then the default degradation coefficient is Cdh = 0.9.  
Version 1.1 - June 2017

Models: Outdoor Unit: Aerona<sup>3</sup> HPID16  
Indoor Unit: None  
Air-to-water heat pump: Yes  
Brine-to-water heat pump: No  
Low temperature heat pump: No  
Equipped with a supplementary heater: No  
Heat Pump Combination Heater: No  
Parameters shall be declared for: Medium temperature applications  
Parameters shall be declared for: Average climate conditions

Item	Symbol	Value	Unit	Item	Symbol	Value	Unit
Rated heat output (*)	Prated	11	kW	Seasonal space heat energy efficiency	s	126	%
Declared capacity for heating for part load at indoor temperature 20°C and outdoor temperature Tj				Declared coefficient of performance or primary energy ratio for part load at indoor temperature 20°C and outdoor temperature Tj			
Tj = -10°C	Pdh	11.0	kW	Tj = -10°C	COPd	1.60	
Degradation co-efficient (**)	Cdh	0.99	-				
Tj = -7°C	Pdh	9.05	kW	Tj = -7°C	COPd	1.81	
Degradation co-efficient (**)	Chd	0.99	-				
Tj = +2°C	Pdh	6.05	kW	Tj = +2°C	COPd	3.26	
Degradation co-efficient (**)	Cdh	0.99	-				
Tj = +7°C	Pdh	3.9	kW	Tj = +7°C	COPd	4.58	
Degradation co-efficient (**)	Cdh	0.99	-				
Tj = +12°C	Pdh	4.50	kW	Tj = +12°C	COPd	5.70	
Degradation co-efficient (**)	Cdh	0.99	-				
Tj = bivalent temperature	Pdh	11.0	kW	Tj = bivalent temperature	COPd	1.60	
Tj = operation limit temperature	Pdh	11.0	kW	Tj = operation limit temperature	COPd	1.60	
Tj = -15°C (if TOL < -20°C)	Pdh	-	kW	Tj = -15°C (if TOL < -20°C)	COPd	-	
Bivalent temperature	Tbiv	-10		Operation limit temperature	TOL	-10	°C
				Heating water operating limit temperature	WTOL	60	°C

Power consumption in modes other than active mode				Supplementary heater			
Off Mode	P <sub>off</sub>	0.01	kW	Rate heat output	P <sub>sup</sub>	0.40	kW
Thermostat off mode	P <sub>to</sub>	0.04	kW				
Standby mode	P <sub>sa</sub>	0.01	kW	Type of energy input			
Crankcase heater mode	P <sub>cx</sub>	0.00	kW				

Other items							
Capacity control	Variable			Rated airflow rate, outdoors	-	4464	m <sup>3</sup> /h
Sound power level indoor/outdoor	L <sub>wa</sub>	42/63	dB(A)				
Annual energy consumption	Q <sub>he</sub>	6996	kWh				

For heat pump combination heater				Water heating energy efficiency			
Declared heat load profile	-	-	-				
Daily electricity consumption	Q <sub>elec</sub>	-	kWh				
Annual electricity consumption	AEC	-	kWh				

(\*) For heat pump space heaters and heat pump combination heaters, the rated heat output Prated is equal to the design load for heating. Pdesignh, and the rated heat output of a supplementary Psup is equal to the supplementary capacity for heating sup(Tj).  
(\*\*) If Cdh is not determined by measurement then the default degradation coefficient is Cdh = 0.9.  
Version 1.1 - June 2017

# 17 GUARANTEE

You are now the proud owner of an Air Source Heat Pump from Grant Engineering (IRL) ULC which has been designed to give years of reliable, trouble free, operation.

Grant Engineering (IRL) ULC guarantees the manufacture of the heat pump including all electrical and mechanical components for a period of **twelve months from the date of installation**<sup>1</sup>, provided that the air source heat pump has been installed in full accordance with the installation and servicing instructions issued.

This will be extended to a total period of **five years** if the air source heat pump is registered with Grant Engineering (IRL) ULC **within thirty days of installation** and it is serviced at twelve monthly intervals<sup>3</sup>. See main Terms and Conditions below.

If the heat pump is installed as part of a VortexAir (hybrid) installation, the guarantee for the heat pump will start from its original date of installation and NOT from the date of installation of the oil boiler (if installed on different dates). If the installation date of the heat pump is more than three months from the date of installation of the oil boiler, the guarantee period will commence three months from the date of installation of the oil boiler.

## Registering the product with Grant Engineering (IRL) ULC

Please register your air source heat pump with Grant Engineering IRL ULC **within thirty days of installation**. To do so visit [www.grantengineering.ie](http://www.grantengineering.ie) where you can register your boiler for a further **twelve months** guarantee (giving **four years** from the date of installation). This does not affect your statutory rights<sup>1</sup>.

## If a fault or defect occurs within the manufacturer's guarantee period

If your air source heat pump should fail within the guarantee period, you must contact Grant Engineering (IRL) ULC, who will arrange for the repair under the terms of the guarantee, providing that the heat pump has been correctly installed, commissioned and serviced (if the appliance has been installed for more than twelve months) by a competent person and the fault is not due to tampering, system water contamination, misuse, trapped air or the failure of any external components not supplied by Grant Engineering (IRL) ULC, e.g. pipework, etc.

## This five year guarantee only applies if the air source heat pump is registered with Grant Engineering (IRL) ULC within thirty days of installation<sup>4</sup> and is serviced after twelve month intervals<sup>3</sup>.

## In the first instance

Contact your installer or commissioning engineer to ensure that the fault does not lie with the system components or any incorrect setting of the system controls that falls outside of the manufacturer's guarantee otherwise a service charge could result. Grant Engineering (IRL) ULC will not be liable for any charges arising from this process.

## If a fault covered by the manufacturer's guarantee is found

Ask your installer to contact Grant Engineering (IRL) ULC Service Department on 057 912 0089 who will arrange for a competent service engineer to attend to the fault.

## Remember - before you contact Grant Engineering (IRL) ULC

- Ensure the air source heat pump has been installed, commissioned and serviced by a competent person in accordance with the installation and servicing instructions.
- Ensure the problem is not being caused by the heating system or its controls.

## Free of charge repairs

During the **five year** guarantee period no charge for parts or labour will be made, provided that the air source heat pump has been installed and commissioned correctly in accordance with the manufacturer's installation and servicing instructions, it was registered with Grant Engineering (IRL) ULC within thirty days of installation<sup>3</sup> and, for air source heat pumps over twelve months old, details of annual service is available<sup>3</sup>.

The following documents must be made available to Grant Engineering (IRL) ULC on request:

- Proof of purchase
- Commissioning Report Form
- Service documents
- System Design Criteria

## Chargeable repairs

A charge may be made (if necessary following testing of parts) if the cause of the breakdown is due to any fault(s) caused by the plumbing or heating system, e.g. contamination of parts due to system contamination, sludge, scale, debris or trapped air. See 'Extent of manufacturer's guarantee' below.

## Extent of manufacturer's guarantee:

The manufacturer's guarantee does not cover the following:

- If the air source heat pump has been installed for over **five years**.
- If the air source heat pump has not been installed, commissioned, or serviced by a competent person in accordance with the installation and servicing instructions.
- The serial number has been removed or made illegible.
- Fault(s) due to accidental damage, tampering, unauthorised adjustment, neglect, misuse or operating the air source heat pump contrary to the manufacturer's installation and servicing instructions.
- Damage due to external causes such as bad weather conditions (flood, storms, lightning), fire, explosion, accident or theft.
- Fault(s) due to incorrectly sized expansion vessel(s), incorrect vessel charge pressure or inadequate expansion on the system.
- Fault(s) caused by external electrics and external components not supplied by Grant Engineering (IRL) ULC.
- Air source heat pump servicing, de-scaling or flushing.
- Checking and replenishing system pressure.
- Electrical cables and plugs, external controls not supplied by Grant Engineering (IRL) ULC.
- Heating system components, such as radiators, pipes, fittings, pumps and valves not supplied by Grant Engineering (IRL) ULC.
- Instances where the heat pump has been un-installed and re-installed in another location.
- Use of spare parts not authorised by Grant Engineering (IRL) ULC.
- Consumable items including antifreeze and biocide inhibitor.

## Terms of manufacturer's guarantee

- The Company shall mean Grant Engineering (IRL) ULC.
- The heat pump must be **installed and commissioned** by a competent installer and in full accordance with the relevant Codes of Practice, Regulations and Legislation in force at the time of installation.
- The heat pump is guaranteed for **five years** from the date of installation<sup>3</sup>, providing that after twelve monthly intervals the annual service has been completed<sup>3</sup> and the heat pump registered with the Company within thirty days of the installation date<sup>3</sup>. Any work undertaken must be authorised by the Company and carried out by a

competent service engineer.

- The internal heat exchanger of the heat pump is also covered by a **five year parts and labour guarantee** from the date of installation<sup>3</sup>. This is subject to the following:
  - o The heat pump is operated correctly, in accordance with the installation and servicing instructions.
  - o Proof is provided that the system has been flushed or chemically cleaned where appropriate (refer to BS 7593) and that the required quantity of a suitable corrosion inhibitor added.
  - o Proof of annual servicing (including the checking of any expansion vessels and pressure relief valves) must be provided if and when requested by the Company.

## IMPORTANT

Grant Engineering (IRL) ULC **strongly recommends** that a Grant Mag-One in-line magnetic filter/s (or equivalent) is fitted in the heating system pipework. This should be installed and regularly serviced in accordance with the filter manufacturer's instructions.

- This guarantee does not cover breakdowns caused by incorrect installation, neglect, misuse, accident or failure to operate the heat pump in accordance with the manufacturer's installation and servicing instructions.
- The heat pump is registered with the Company within thirty days of installation. Failure to do so does not affect your statutory rights<sup>1</sup>.
- The balance of the guarantee is transferable providing the installation is serviced prior to the dwelling's new owners taking up residence. Grant Engineering (IRL) ULC must be informed of the new owner's details.
- The Company will endeavour to provide prompt service in the unlikely event of a problem occurring, but cannot be held responsible for any consequences of delay however caused.
- This guarantee applies to air source heat pumps purchased and installed in Ireland and Northern Ireland. Provision of in-guarantee cover elsewhere in Ireland is subject to agreement with the Company.
- All claims under this guarantee must be made to the Company prior to any work being undertaken. Invoices for call out/repair work by any third party will not be accepted unless previously authorised by the Company.
- Proof of purchase and date of installation, commissioning and service documents must be provided on request.
- If a replacement heat pump is supplied under the guarantee (due to a manufacturing fault) the product guarantee continues from the installation date of the original heat pump, and not from the installation date of the replacement<sup>3</sup>.
- The replacement of a heat pump under this guarantee does not include any consequential costs.

## Foot notes

1. Your statutory rights entitle you to a one year guarantee period only.
2. We recommend that your air source heat pump is serviced every twelve months (even when the guarantee has expired) to prolong the lifespan and ensure it is operating safely and efficiently.
3. The guarantee period will commence from the date of installation, unless the installation date is more than six months from the date of purchase, in which case the guarantee period will commence six months from the date of purchase.
4. As measured by gauss. The Mag-One magnetic filter has a Gauss measurement of 12000.

Version 1.0 - June 2019

# APPENDIX A PARAMETERS LIST

## Backlight display parameters

Level	Parameter		Function description	Display and input value				Remarks
	Group	Code		Default	Min.	Max.	Unit	
U	02	03	Back light display at door open 0=OFF 1=ON	1	0	1	-	
U	02	04	Time to turn off the back light display	60	10	300	10 sec	
U	02	05	Time to back to normal display screen	120	10	300	10 sec	

## Water temperature set points

Level	Parameter		Function description	Display and input value				Remarks
	Group	Code		Default	Min.	Max.	Unit	
I	21	00	Enable outgoing water set point 0=fixed set point 1=climatic curve	1	0	1	-	
I	21	01	Fixed outgoing water set point	45.0	23.0	60.0	0.5°C	
I	21	02	Maximum outgoing water temperature in Heating mode (Tm1)	45.0	23.0	60.0	0.5°C	
I	21	03	Minimum outgoing water temperature in Heating mode (Tm2)	30.0	23.0	60.0	0.5°C	
I	21	04	Minimum outdoor air temperature corresponding to maximum outgoing water temperature (Te1)	-4	-20.0	50.0	0.5°C	
I	21	05	Maximum outdoor air temperature corresponding to maximum outgoing water temperature (Te2)	20.0	0.0	40.0	0.5°C	
I	21	41	Hysteresis of water set point in heating	8.0	0.5	10.0	0.5°C	
I	21	51	Low tariff deferential water set point for Heating	5.0	0.0	60.0	0.5°C	

## DHW (Domestic Hot Water)

Level	Parameter		Function description	Display and input value				Remarks
	Group	Code		Default	Min.	Max.	Unit	
I	31	01	DHW production priority setting 0=DHW is unavailable 1= DHW is available, and priority DHW over space heating 2= DHW is available, and priority space Heating over DHW	1	0	2	-	
I	31	21	Maximum time for DHW request	60	0	900	1 min	
I	31	22	Minimum time for space heating	15	0	900	1 min	

## Heat pump unit

Level	Parameter		Function description	Display and input value				Remarks
	Group	Code		Default	Min.	Max.	Unit	
I	41	00	The heat pump turns ON/OFF based on 1=water set point	1	0	1	-	
I	41	11	Maximum frequency of Night mode	80	50	100	5%	
S	41	30	Maximum outgoing water set point in CH and DHW	55.0	23.0	60.0	0.5°C	

## Water pump

Level	Parameter		Function description	Display and input value				Remarks
	Group	Code		Default	Min.	Max.	Unit	
I	42	00	Type of configuration of main water pump 0=always ON 1=ON/OFF based on buffer tank temperature 2=ON/OFF based on detect cycles	0	0	2	-	To be set to the following combinations parameter 5111=0 Parameter 4200=0 or 2 parameter 5111=1 Parameter 4200=0 or 1 or 2
I	42	01	Time ON main water pump for detect cycle	3	1	15	1 min	
I	42	02	Time OFF main water pump	5	5	30	1 min	
I	42	03	Delay time OFF main water pump from OFF compressor	3	1	15	1 min	
I	42	11	OFF time for unblock pump function start	48	0	240	1 hr	
I	42	12	Time ON main water pump for unblock pump function	5	0	10	1 sec	

I	42	20	Type of operation of additional water pump 0=disable 1=depending on main water pump setting 2=depending on main water pump setting but always OFF when the DHW mode is activated 3=always ON, apart from if any alarms are activated or if the heat pump is in OFF mode	0	0	3	-	
---	----	----	---	---	---	---	---	--

## Frost protection

Level	Parameter		Function description	Display and input value				Remarks
	Group	Code		Default	Min.	Max.	Unit	
S	43	00	Frost protection on room temperature 0=disable 1=enable	1	0	1	-	
I	43	01	Start temperature of frost protection on room air temperature	14.0	0.0	5.0	0.5°C	
I	43	02	Hysteresis of room air temperature of frost protection	1.0	0.5	5.0	0.5°C	
S	43	10	Frost protection by outside temperature 0=disable 1=enable	1	0	1	-	
I	43	11	Start temperature of frost protection on outdoor air temperature	4.0	0.0	10.0	0.5°C	
I	43	12	Hysteresis of outdoor air temperature	3.0	0.5	5.0	0.5°C	
I	43	14	Hysteresis of flow water temperature	3.0	0.5	5.0	0.5°C	
S	43	20	Frost protection based on outgoing water temperature 0=disable 1=enable	1	0	1	-	
I	43	21	Start temperature of frost protection on flow water temperature	4.0	0.0	10.0	0.5°C	
I	43	22	Hysteresis of flow water temperature	3.0	0.5	5.0	0.5°C	
S	43	30	DHW storage frost protection 0=disable 1=enable	1	0	1	-	

## Input/output

Level	Parameter		Function description	Display and input value				Remarks
	Group	Code		Default	Min.	Max.	Unit	
I	51	11	Terminal 11-12: thermal store temperature probe 0=disable 1=enable	0	0	1	-	To be set to the following combinations parameter 5111=0 Parameter 4200=0 or 2 parameter 5111=1 Parameter 4200=0 or 1 or 2
I	51	19	Terminal 19-18 : DHW remote contact 0=disable (Remote controller only) 1=enable	1	0	1	-	
I	51	20	Terminal 20-21 : ON/OFF remote contact (CH) Alarm input 0=disable 1=ON/OFF remote contact	1	0	1	-	ON/OFF by Remote controller 0=enable 1=ON/disable OFF/enable 2=enable
I	51	28	Terminal 28-29 : Night mode* 0=disable 1=enable Refer to Section 8.6.	0	0	1	-	Parameter 5128 and Parameter 5130 are synchronised in same value
I	51	30	Terminal 30-31 : Low tariff* 0=disable 1=enable Refer to Section 8.7.	0	0	1	-	
I	51	46	Terminal 46 : DHW Electric heater or Backup heater 0=DHW Electric heater 1=Backup heater	0	0	1	-	
I	51	48	Terminal 48 0=disable 1=additional water pump	0	0	1	-	

\* External timer required



# APPENDIX B WIRING DIAGRAMS

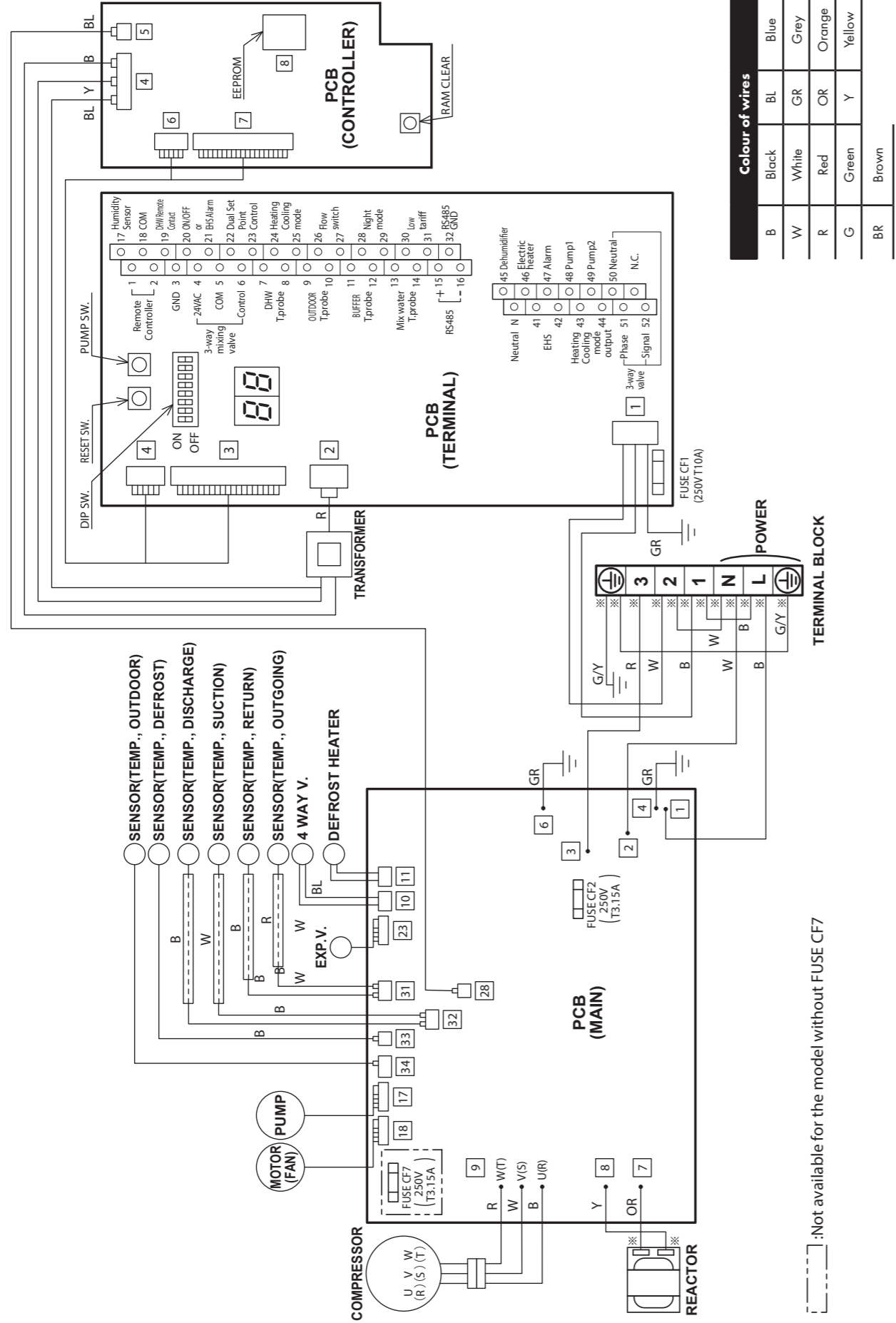

[---]: Not available for the model without FUSE CF7

HPID6 and HPID10 circuit diagram

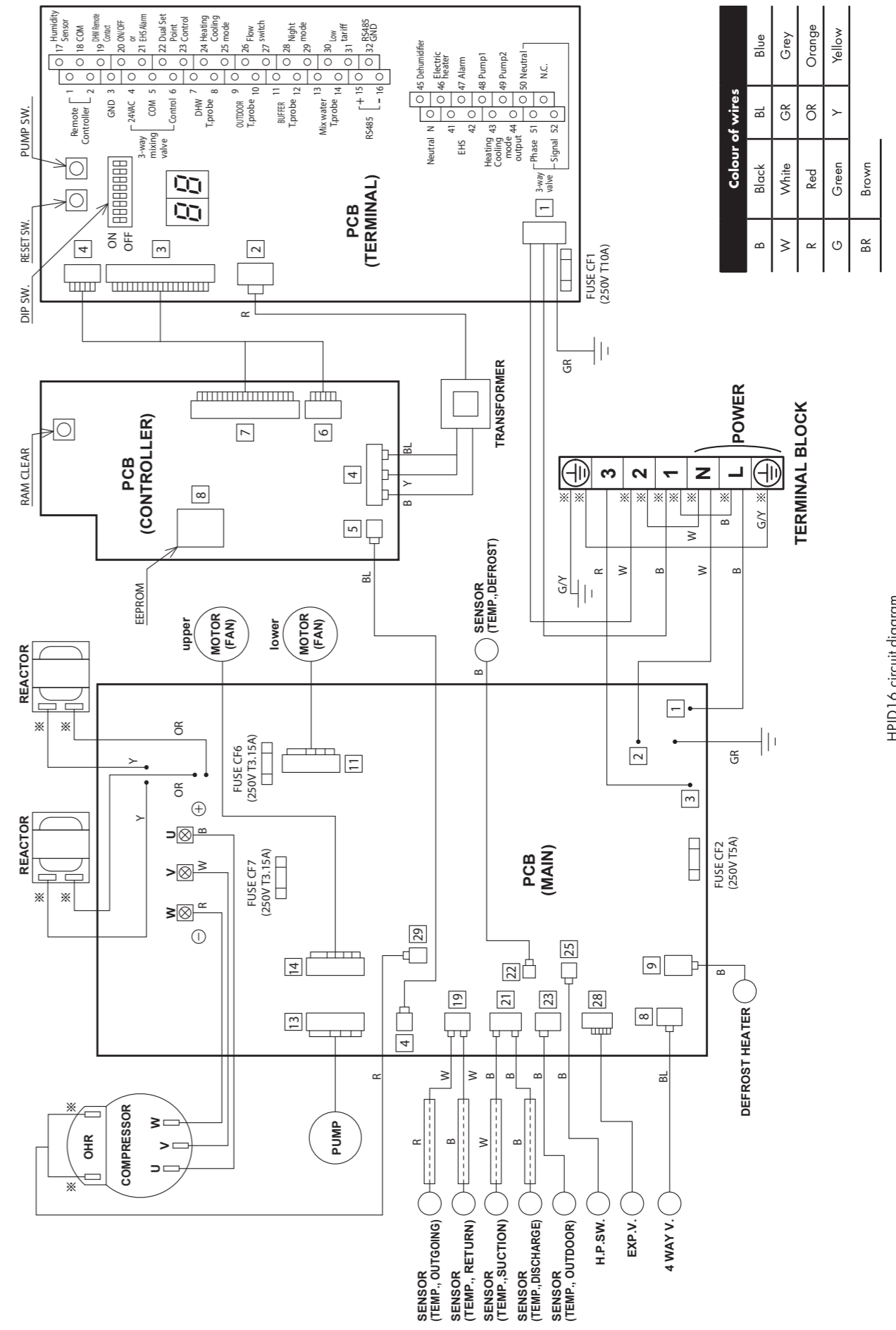

HPID16 circuit diagram

# APPENDIX C COMMISSIONING- PARAMETERS RECORD

This section enables the installer/commissioning engineer to record details of any parameters that may have changed during commissioning.  
Refer to Appendix A for full details of parameter settings.

Level	Parameter		Function description	Default	Value set on commissioning
	Group	Code			
I	21	00	Enable outgoing water set point 0=fixed set point 1=climatic curve	1	
I	21	01	Fixed outgoing water set point	45.00	
I	21	02	Maximum outgoing water temperature in Heating mode (Tm1)	45.00	
I	21	03	Minimum outgoing water temperature in Heating mode (Tm2)	30.00	
I	21	04	Minimum outdoor air temperature corresponding to maximum outgoing water temperature (Te1)	-4	
I	21	05	Maximum outdoor air temperature corresponding to maximum outgoing water temperature (Te2)	20.0	
I	31	01	DHW production priority setting 0=DHW is unavailable 1= DHW is available, and priority DHW over space heating 2= DHW is available, and priority space heating over DHW	1	
I	31	21	Maximum time for DHW request	60	
I	31	22	Minimum time for space heating	15	
I	41	00	The heat pump turns ON/OFF based on 1=water set point	1	
I	41	11	Maximum frequency of night mode	80	
S	41	30	Maximum outgoing water set point in CH and DHW	55°C	
I	42	00	Type of configuration of main water pump 0=always ON 1=ON/OFF based on buffer tank temperature 2=ON/OFF based on detect cycles	0	
I	42	01	Time ON main water pump for detect cycle	3	
I	42	02	Time OFF main water pump	5	
I	42	03	Delay time OFF main water pump from OFF compressor	3	
I	42	11	OFF time for unblock pump function start	48	
I	42	12	Time ON main water pump for unblock pump function	5	
I	42	20	Type of operation of additional water pump 0=disable 1=depending on main water pump setting 2=depending on main water pump setting but always OFF when the DHW mode is activated 3=always ON, apart from if any alarms are activated or if the heat pump is in OFF mode	0	
S	43	00	Frost protection on room air temperature 0=disable 1=enable	1	
I	43	01	Start temperature of frost protection on room air temperature	14.0	
I	43	02	Hysteresis of room air temperature of frost protection	1.0	
S	43	10	Frost protection on outdoor air temperature 0=disable 1=enable	1	
I	43	11	Start temperature of frost protection on outdoor air temperature	4.0	
I	43	12	Hysteresis of outdoor air temperature	3.0	
I	43	14	Hysteresis of flow water temperature	3.0	
S	43	20	Frost protection on outgoing water temperature 0=disable 1=enable	1	
I	43	21	Start temperature of frost protection on flow water temperature	4.0	
I	43	22	Hysteresis of flow water temperature	3.0	
S	43	30	DHW storage frost protection 0=disable 1=enable	1	

I	51	11	Terminal 11-12: thermal store temperature probe 0=disable 1=enable	0	
I	51	19	Terminal 19-18 : DHW remote contact 0=disable (Remote controller only) 1=enable	1	
I	51	20	Terminal 20-21 : ON/OFF remote contact (CH) Alarm input 0=disable 1=ON/OFF remote contact	1	
I	51	28	Terminal 28-29 : Night mode 0=disable 1=enable	0	
I	51	30	Terminal 30-31 : Low tariff 0=disable 1=enable	0	
I	51	48	Terminal 48 0=disable 1=additional water pump	0	
Pump output setting			DIP SW5 - OFF DIP SW6 OFF Level 1 (maximum) DIP SW5 - ON DIP SW6 - OFF Level 2 (medium) DIP SW5 - OFF DIP SW6 - ON Level 3 (minimum)	Level 1	



**GRANT ENGINEERING (IRELAND) ULC**

Crinkle, Birr, Co. Offaly, R42 D788, Ireland  
Tel: +353 (0)57 91 20089 Fax: +353 (0)57 91 21060  
Email: [info@grantengineering.ie](mailto:info@grantengineering.ie) [www.grantengineering.ie](http://www.grantengineering.ie)